

# PREFACE

Thanks for choosing V560 Series High Performance Closed-Loop Vector Frequency Inverter produced by Shenzhen Sunfar Electric Technologies Co, Ltd.

This Manual is the operating manual for V560 series closed-loop vector frequency inverter. It provides all relevant instructions and precautions for installation, wiring, functional parameters, daily care and maintenance, fault diagnosis and troubleshooting of V560 series inverter.

In order to use this product correctly, guarantee product's best performance and ensure safety of users and equipment, be sure to read this manual carefully before using V560 series inverters. Improper use may cause abnormality and malfunction of the inverter, reduce its service life and even damage equipments and lead to personal injury and death, etc.

This user manual is delivered with the device. Please keep it property for future overhaul and maintenance.

Owing to constant improvement of products, all data may be changed without further notice.



V560 Series High Performance Closed-Loop Vector Inverter User Manual

Version: V1.4

Revision Date: April. 2017

**This Manual is applicable to V6005 and above programs.**

# CATALOG

<b>1. PRODUCT CONFIRMATION AND OPERATION CAUTIONS .....</b>	<b>1</b>
1.1 PRODUCT CONFIRMATION .....	1
1.1.1 CONFIRMATION OF FREQUENCY INVERTER BODY AND ACCESSORIES .....	1
1.1.2 NAMEPLATE OF FREQUENCY INVERTER .....	1
1.2 SAFETY CAUTIONS .....	1
1.2.1 NOTICES DURING INSTALLATION .....	2
1.2.2 SAFETY CAUTION FOR WIRING .....	2
1.2.3 SAFETY CAUTION FOR RUNNING OPERATION .....	2
1.2.4 SAFETY CAUTION FOR MAINTENANCE CHECK .....	3
1.3 KNOWLEDGE ON OPERATION .....	3
1.3.1 APPLICATION KNOWLEDGE OF DRIVING GENERAL MOTOR .....	3
1.3.2 APPLICATION KNOWLEDGE OF DRIVING SPECIAL MOTOR .....	3
1.3.3 AMBIENT ENVIRONMENT .....	3
1.3.4 CONNECTION KNOWLEDGE OF PERIPHERAL EQUIPMENT .....	3
1.3.5 TRANSPORTATION AND STORAGE .....	4
1.4 ABANDON CAUTION .....	4
1.5 OTHER CAUTIONS .....	4
<b>2. PRODUCTION INTRODUCTION .....</b>	<b>5</b>
2.1 INVERTER MODEL .....	5
2.2 PRODUCT APPEARANCE .....	5
2.3 MODEL TABLE .....	7
2.4 PRODUCT TECHNICAL INDEX AND SPECIFICATIONS .....	8
<b>3. INSTALLATION OF FREQUENCY INVERTER .....</b>	<b>11</b>
3.1 INSTALLATION OF FREQUENCY INVERTER .....	11
3.1.1 MOUNTING SURFACE .....	11
3.1.2 INSTALLATION SPACE .....	11
3.1.3 MULTIPLE INSTALLATIONS .....	11
3.2 SIZE AND ASSEMBLY OF OPERATION PANEL .....	12
3.3 DISASSEMBLY OF TERMINAL COVER .....	13
3.3.1 DISASSEMBLY AND INSTALLATION OF PLASTIC COVER PLATE .....	14
3.3.2 DISASSEMBLY AND INSTALLATION OF SHEET-METAL COVER PLATE .....	14
3.4 INSTALLATION SIZE OF PANEL .....	15
3.5 DISASSEMBLY AND INSTALLATION OF EXPANSION BOARD .....	16

3.6 INSTALLATION AND DISASSEMBLY OF FUNCTION BOARD.....	16
3.7 INSTALLATION SIZE OF FREQUENCY INVERTER.....	17
<b>4. WIRING OF FREQUENCY INVERTER .....</b>	<b>20</b>
4.1 CAUTIONS OF WIRING .....	20
4.2 CONNECTION OF OPTIONAL FITTINGS AND FREQUENCY INVERTER .....	21
4.3 WIRING OF CONTROL TERMINAL .....	26
4.3.1 WIRING OF CONTROL PANEL STANDARD TERMINAL CON1 AND CON2...	26
4.3.2 FUNCTION DESCRIPTION OF CONTROL TERMINAL.....	26
4.3.3 CAUTIONS TO THE WIRING OF CONTROL TERMINAL .....	27
4.3.4 DESCRIPTION OF DIP SWITCH ON CONTROL PANEL.....	27
4.4 WIRING OF MAJOR LOOP TERMINAL .....	28
4.4.1 TERMINAL FUNCTIONS .....	28
4.4.2 WIRING OF MAJOR LOOP TERMINAL AND TERMINAL BLOCKS.....	28
4.5 WIRING CONNECTION OF BASIC OPERATION .....	32
<b>5. OPERATION AND SIMPLE RUNNING OF FREQUENCY INVERTER.....</b>	<b>33</b>
5.1 BASIC FUNCTION OF PANEL .....	33
5.2 BASIC FUNCTIONS AND OPERATING METHODS OF PANEL .....	34
5.2.1 BASIC FUNCTIONS OF PANEL .....	34
5.2.2 OPERATING METHODS OF PANEL.....	36
5.3 SIMPLE RUNNING OF FREQUENCY INVERTER .....	38
5.3.1 OPERATION PROCESS.....	38
5.3.2 INITIAL SETTING OF FREQUENCY INVERTER .....	40
5.3.3 SIMPLE OPERATION .....	41
5.3.3.1 SVC (NON-INDUCTIVE VECTOR) OPERATION .....	41
5.3.3.2 VC (INDUCTIVE VECTOR) OPERATION.....	42
<b>6. FUNCTIONAL PARAMETER TABLE.....</b>	<b>43</b>
6.1 EXPLANATIONS.....	43
6.2 FUNCTION TABLE.....	43
6.2.1 SYSTEM MANAGEMENT PARAMETER.....	43
6.2.2 SELECTION OF RUNNING COMMANDS .....	46
6.2.3 FREQUENCY SETTING .....	47
6.2.4 CONTROL COMMAND SOURCE.....	48
6.2.5 START AND STOP.....	48
6.2.6 ACCELERATION AND DECELERATION CHARACTERISTICS PARAMETERS.....	50
6.2.7 CARRIER FREQUENCY.....	50

6.2.8 V/F PARAMETERS AND OVERLOAD PROTECTION (MOTOR 1).....	51
6.2.9 V/F PARAMETERS AND OVERLOAD PROTECTION (MOTOR 2).....	51
6.2.10 STEADY RUNNING .....	52
6.2.11 VECTOR RUNNING PARAMETERS (MOTOR 1).....	53
6.2.12 VECTOR RUNNING PARAMETERS (MOTOR 2).....	53
6.2.13 PARAMETER MEASUREMENT AND PRE-EXCITATION.....	54
6.2.14 MULTIFUNCTIONAL INPUT TERMINAL .....	54
6.2.15 MULTIFUNCTIONAL OUTPUT TERMINAL .....	55
6.2.16 PULSE INPUT.....	56
6.2.17 PULSE OUT.....	57
6.2.18 ANALOG INPUT.....	57
6.2.19 ANALOG INPUT CURVE CORRECTION .....	57
6.2.20 ANALOG OUTPUT.....	58
6.2.21 ANALOG INPUT POWER FAILURE DETECTION.....	59
6.2.22 VIRTUAL ANALOG INPUT.....	60
6.2.23 HOPPING FREQUENCY .....	60
6.2.24 BUILT-IN AUXILIARY TIMER .....	61
6.2.25 BUILT-IN AUXILIARY COUNTER.....	63
6.2.26 AUXILIARY FUNCTIONS.....	64
6.2.27 MOTOR TEMPERATURE DETECTION .....	65
6.2.28 MULTI-STAGE FREQUENCY SETTING.....	65
6.2.29 SIMPLE PROGRAMMABLE MULTI-STAGE OPERATION .....	66
6.2.30 SWING FREQUENCY OPERATION.....	67
6.2.31 PROCESS PID (4MS CONTROL CYCLE).....	68
6.2.32 PROCESS PID MULTI-STAGE SETTING.....	70
6.2.33 PROCESS PID SLEEP FUNCTION.....	71
6.2.34 REVOLUTION SETTING AND FEEDBACK.....	71
6.2.35 REVOLUTION CLOSED-LOOP PARAMETER .....	72
6.2.36 PROTECTION PARAMETER.....	73
6.2.37 TORQUE CONTROL .....	74
6.2.38 COMPENSATION PID (RUNNING CYCLE: 1MS) .....	75
6.2.39 COMPENSATION PID CONTROLLER PARAMETER SELECTION.....	77
6.2.40 MODBUS FIELDBUS (STANDARD EXPANSION CARD CONFIGURATION).....	78
6.2.41 MAPPING ACCESS PARAMETER .....	79
6.2.42 COMMUNICATION LINKAGE SYNCHRONOUS CONTROL .....	79
6.2.43 EXPANSION MULTIFUNCTIONAL INPUT TERMINAL.....	80

6.2.44 EXPANSION MULTIFUNCTIONAL OUTPUT TERMINAL.....	81
6.2.45 SERVOCONTROL AND SCALE POSITIONING.....	81
6.2.46 VIRTUAL INPUT AND OUTPUT .....	83
6.2.47 PROTECTION FUNCTION CONFIGURATION PARAMETER .....	85
6.2.48 CORRECTION PARAMETER .....	86
6.2.49 SPECIAL FUNCTIONAL PARAMETERS .....	86
6.2.50 OTHER CONFIGURATION PARAMETERS .....	87
6.2.51 HISTORICAL FAULT RECORDING .....	88
6.2.52 OPERATION STATUS AT THE LAST FAULT .....	88
6.2.53 BASIC STATUS PARAMETER.....	89
6.2.54 AUXILIARY STATUS PARAMETER .....	91
6.2.55 MODBUS FIELDBUS STATUS PARAMETER (Standard Expansion Card) .....	91
6.2.56 TERMINAL STATUS AND VARIABLE .....	92
6.2.57 COUNTER TIMER VALUE .....	92
6.2.58 SPINDLE CONTROL AND SCALE POSITIONING STATUS PARAMETER ....	93
6.2.59 EQUIPMENT INFORMATION .....	93
<b>7. DESCRIPTION OF SPECIFIC FUNCTIONS .....</b>	<b>98</b>
7.1 SYSTEM MANAGEMENT (GROUP F0.0) .....	98
7.2 RUNNING COMMAND SELECTION (GROUP F0.1).....	106
7.3 FREQUENCY SETUP (GROUP F0.2) .....	112
7.4 CONTROL COMMAND SOURCE (GROUP F0.3).....	116
7.5 START AND STOP (GROUP F0.4) .....	117
7.6 ACCEL AND DECEL CHARACTERISTICS (GROUP F1.0) .....	124
7.7 CARRIER FREQUENCY (GROUP F1.1) .....	126
7.8 V/F PARAMETERS AND OVERLOAD PROTECTION (MOTOR 1) (GROUP F1.2) .....	127
7.9 V/F PARAMETERS AND OVERLOAD PROTECTION (MOTOR 2) (GROUP F1.3) .....	129
7.10 STEADY RUNNING (GROUP F1.4).....	129
7.11 VECTOR RUNNING PARAMETERS (MOTOR 1) (GROUP F2.0) .....	133
7.12 PARAMETER MEASUREMENT AND PRE-EXCITATION (GROUP F2.2) .....	134
7.13 MULTIFUNCTIONAL INPUT TERMINAL (GROUP F3.0).....	135
7.14 MULTIFUNCTIONAL OUTPUT TERMINAL (GROUP F3.1) .....	143
7.15 PULSE INPUT (GROUP F3.2) .....	146
7.16 PULSE OUTPUT (GROUP F3.3) .....	147
7.17 ANALOG INPUT (GROUP F4.0) .....	148
7.18 ANALOG INPUT CURVE CORRECTION (GROUP F4.1).....	149
7.19 ANALOG OUTPUT (GROUP F4.2) .....	149

7.20 ANALOG INPUT WIRE-BREAK DETECTION (GROUP F4.3).....	151
7.21 HOPPING FREQUENCY (GROUP F5.0).....	151
7.22 BUILT-IN AUXILIARY TIMER (GROUP F5.1).....	152
7.22.1 BASIC FUNCTIONS OF THE TIMER .....	152
7.22.2 TRIGGER AND GATE CONTROL FUNCTION SETTING OF TIMER.....	153
7.22.3 CLOCK CONCATENATION FUNCTION SETTING OF TIMER .....	153
7.22.4 CONCATENATION TRIGGER FUNCTION SETTING OF TIMER .....	154
7.23 BUILT-IN AUXILIARY COUNTER (GROUP F5.2).....	154
7.24 AUXILIARY FUNCTIONS (GROUP F5.3) .....	155
7.25 MOTOR TEMPERATURE DETECTION (GROUP F5.4).....	158
7.26 MULTI-STAGE FREQUENCY SETTING (GROUP F6.0).....	160
7.27 SIMPLE PROGRAMMABLE MULTI-STAGE OPERATION (GROUP F6.1).....	164
7.28 SWING FREQUENCY OPERATION (GROUP F6.2) .....	164
7.29 PROCESS PID (4MS CONTROL CYCLE) (GROUP F7.0) .....	168
7.30 PROCESS PID MULTI-STAGE SETTING (GROUP F7.1) .....	173
7.31 PROCESS PID SLEEPING FUNCTION (GROUP F7.2).....	173
7.32 REVOLUTION SETTING AND FEEDBACK (GROUP F8.0) .....	173
7.33 REVOLUTION CLOSED-LOOP PARAMETER (GROUP F8.1).....	176
7.34 PROTECTIVE PARAMETERS (GROUP F8.2) .....	177
7.35 TORQUE CONTROL (GROUP F8.3).....	178
7.36 COMPENSATION PID (1MS CONTROL CYCLE) (GROUP F9.0).....	181
7.37 PARAMETER SELECTION OF COMPENSATION PID CONTROLLER.....	182
7.38 MODBUS FIELDBUS (GROUP FA.0) .....	183
7.39 MAPPING PARAMETER ACCESS (GROUP FA.1) .....	183
7.40 COMMUNICATION LINKAGE SYNCHRONOUS CONTROL (GROUP FA.2).....	184
7.41 EXPANSION MULTIFUNCTIONAL INPUT TERMINAL (GROUP FB.0 AND FB.1) .....	186
7.42 SERVO CONTROL AND SCALE POSITIONING (GROUP FB.2).....	186
7.43 VIRTUAL INPUT AND OUTPUT (GROUP FF.0).....	189
7.44 PROTECTING FUNCTION CONFIGURATION PARAMETERS (GROUP FF.1).....	190
7.45 CORRECTION PARAMETERS (GROUP FF.2) .....	190
7.46 SPECIAL FUNCTIONAL PARAMETERS (GROUP FF.3).....	192
7.47 OTHER CONFIGURATION PARAMETERS (GROUP FF.4) .....	192
<b>8. WARNING, ALARM DIAGNOSIS AND COUNTER MEASURES.....</b>	<b>194</b>
8.1 TROUBLESHOOTING WITH WARNING OR ALARM DISPLAY.....	194
8.1.1 ALARM DISPLAY AND TROUBLESHOOTING .....	194
8.1.2 WARNING DISPLAY AND TROUBLESHOOTING .....	199

8.2 ABNORMAL OPERATION WITHOUT PROMPTS AND THE SOLUTIONS .....	202
8.3 FAILURES IN SETTING OPERATION OF FREQUENCY INVERTER.....	205
8.4 INQUIRY FOR FAILURE RECORD .....	206
8.5 RESET OF WARNING OR ALARM FAILURE.....	207
<b>9. MAINTENANCE.....</b>	<b>208</b>
9.1 ROUTINE MAINTENANCE .....	208
9.2 INSPECTION AND DISPLACEMENT OF THE VULNERABLE COMPONENTS.....	209
9.2.1 FILTER CAPACITOR.....	209
9.2.2 COOLING FAN .....	209
9.3 STORAGE .....	210
9.4 WARRANTY.....	210
<b>10. EXAMPLE OF USAGE.....</b>	<b>211</b>
10.1 ENERGY-SAVING TRANSFORMATION OF ESCALATORS .....	211
10.1.1 SCHEME DESCRIPTION .....	211
10.1.2 WIRING DIAGRAM .....	212
10.2 MAKE SIMPLE TENSION CLOSED-LOOP CONTROL WITH OFFSET PID.....	212
10.2.1 DIAGRAM OF CONSTANT TENSION CONTROL.....	213
10.2.2 DIAGRAM OF CONTROL STRUCTURE .....	213
10.2.3 CONFIGURATION .....	213
10.2.4 WIRING DIAGRAM .....	214
10.3 APPLICATION IN MECHANICAL FACTORY .....	215
10.3.1 CONFIGURATION .....	215
10.3.2 EXTERNAL CIRCUIT WIRING DIAGRAM.....	215
10.4 MULTI-PID SETUP, MULTI-PART PID SETUP, FORM A MULTI- STEP PIDSETUP .	216
10.4.1 PARAMETER SETUP .....	216
10.4.2 DIAGRAM OF STEP PID VALUE GIVEN.....	216
<b>11. DESCRIPTION OF COMMUNICATION PROTOCOL .....</b>	<b>217</b>
11.1 MODBUS PROTOCOL DESCRIPTION .....	217
11.1.1 PROTOCOL OVERVIEW .....	217
11.1.2 INTERFACE AND TRANSMISSION METHOD .....	217
11.1.3 DATA STRUCTURE .....	217
11.1.4 PARAMETER CONFIGURATION FOR FREQUENCY INVERTERS .....	217
11.1.5 BRIEF INTRODUCTION OF FUNCTIONS.....	218
11.1.6 ACCESS ADDRESS SUMMARY.....	218
11.1.7 DETAILED MODBUS ADDRESS-FINDING DISTRIBUTION .....	219
11.1.8 EXAMPLES .....	224

<b>12. EMC</b> .....	<b>226</b>
12.1 CE .....	226
12.2 DEFINITION.....	226
12.3 OBEY STANDARD ORDER.....	226
12.3.1 OBEY EMC ORDER .....	226
12.3.2 OBEY LVD ORDER.....	226
12.4 GUIDANCE OF EMC EXTERNAL ACCESSORIES INSTALLATION AND Selection ..	227
12.4.1 NOTICE OF I EMI INPUT FILTER INSTALLATION .....	227
12.4.2 DC REACTOR .....	227
12.4.3 FU INPUT REACTOR.....	228
12.4.4 AC OUTPUT REACTOR .....	229
12.5 SHIELDED CABLE .....	231
12.6 CABLE WIRING REQUIREMENTS .....	231
12.7 LEAKAGE CURRENT RESPONSE REQUIREMENTS .....	232
12.8 COMMON EMC INTERFERENCE PROBLEM AND SOLUTION .....	233
<b>13. ACCESSORIES</b> .....	<b>234</b>
13.1 BRAKE ASSEMBLY .....	234
13.1.1 MODEL OF BRAKE UNIT .....	234
13.1.2 GUIDE OF BRAKE RESISTANCE SELECTION .....	234
13.1.3 APPEARANCE OF BRAKE UNIT .....	236
13.1.4 INSTALLATION SIZE OF BRAKE UNIT.....	236
13.1.5 SINGLE BRAKE UNIT AND INVERTER REFERENCE WIRING SKETCH ...	237
13.1.6 WIRING PRECAUTIONS .....	237
13.2 I/O EXPANSION CARD (STANDARD TYPE: DEC350VS, PN: 050M008003000).....	238
13.3 PG EXPANSION CARD (STANDARD DEB3PG12VA, PN: 050M009012002).....	239
13.4 INTRODUCTION OF LCD OPERATING PANEL .....	240
13.4.1 OUTSIDE VIEW OF LCD OPERATING PANEL.....	240
13.4.2 LED OPERATION PANEL.....	240
13.4.3 FUNCTION OF KEYS .....	240



# 1. PRODUCT CONFIRMATION AND OPERATION CAUTIONS

## 1.1 PRODUCT CONFIRMATION

Check the outer packing carefully to see if there is any damage after the arrival of the goods; if there is a label on the outer packing, please confirm the model and specification of it to see if they are in accordance with your order. If any damage or discrepancy is found, please contact the supplier promptly for solution.

### 1.1.1 CONFIRMATION OF FREQUENCY INVERTER BODY AND ACCESSORIES



Confirm the frequency inverter body and accessories carefully when unpacking, to see if there is any damage during the transit, and if the parts and components are damaged or dropped, and if there is the frequency inverter entity and the following accessories:

- Operation instruction;
- Certification;
- Product list;
- Other ordered accessories

If there is any omission or damage, please contract the supplier promptly for solution.

### 1.1.2 NAMEPLATE OF FREQUENCY INVERTER

On the frequency inverter, there is a nameplate marked with model, rated parameters, product serial-number and bar code of frequency inverter. The content of nameplate is shown as below:

TYPE:	V560-4T0022G/4T0030P	Model of frequency inverter
SOURCE:	3PH 380V 50/60Hz	Rated input voltage number of phase, voltage and frequency
OUTPUT:	3.6KVA 5.5A/4.9KVA 7.5A	Rated output capability and current
SERIAL No.:	XXXXXXXXXX	Product serial-number
		Certification logos
		Bar code
<small>SHENZHEN SUNFAR ELECTRIC TECHNOLOGIES CO.,LTD MADE IN CHINA</small>		

## 1.2 SAFETY CAUTIONS

Read this instruction carefully prior to installation, wiring, operation and maintenance, to ensure proper operation of this product.

"Tips", "Attention", "Warning" and "Danger" in this operation manual are defined as follow:



- Tips: Tips for some useful information.



- Attention: Matter requires attention during operation.



- Warning: Without operation according to the requirements, moderate injuries or minor injuries of personnel and material loss may be caused.



- Danger: Without operation according to the requirements, serious damage to the equipment or personnel injuries may be caused.

### **1.2.1 NOTICES DURING INSTALLATION**

1. The frequency inverter shall not be installed on combustibles, in case of the risk of fire.
2. The frequency inverter shall not be installed at places with direct sunlight, in case of danger.
3. The frequency inverter of this series shall not be installed in the environment of explosive gases, in case of the danger of explosion.
4. Do not install the Frequency inverter if damaged or If components are missing. Installation may lead to personal injury, fire or other accidents.
5. Do not remove or modify the frequency inverter without authorization.
6. No foreign matter is allowed to be dropped into the frequency inverter, in case of breakdown of the frequency inverter.
7. During installation, the frequency inverter shall be installed at the place able to bear its weight; otherwise, it may fall down.

### **1.2.2 SAFETY CAUTION FOR WIRING**

1. Please authorize the professional staff to conduct wiring. If the wiring operation is not proper, it may damage to the equipment and the individuals.
2. Please start to wire after the panel digital tube of frequency inverter is out for ten minutes, otherwise, there can be electric shock risk.
3. The grounding terminal of frequency inverter must be reliably grounded; otherwise, there can be electric shock risk.
4. Connection of AC power onto the output terminals U, V and W of frequency inverter, will damage the frequency inverter, and may lead to personal injury.
5. Confirm that the input voltage and frequency converter are in consistent with rated voltage value; otherwise, the frequency inverter may be damaged.
6. Confirm that the motor and frequency converter are adaptive with each other, otherwise, the motor can be damaged or frequency converter protection can be caused.
7. Brake resistor cannot be connected onto the (+), (-) of DC bus directly; otherwise, there can be fire risk.

### **1.2.3 SAFETY CAUTION FOR RUNNING OPERATION**

1. Please do not operate the switch with wet hand; otherwise, there can be electric shock.
2. Please install the front cover prior to plugging in, and shall not demount the cover while power is on, otherwise, here can be electric shock.
3. During the frequency converter is with power on, even the motor is stopped, do not touch the terminals of frequency converter, otherwise, here can be electric shock.
4. If you apply the function of restart, do not approach the load equipment, for it may restart suddenly after alarm removed, otherwise, personal injuries may caused. Please set the system as ensuring personal and property safety even when restarting.
5. Please set additional emergency stop switch, otherwise, personal injuries may be caused.
6. The temperature of cooling fin and direct current reactor can be very high, therefore, do not touch them, in case of the danger of burns.

## 1.2.4 SAFETY CAUTION FOR MAINTENANCE CHECK

1. Maintenance operations of overhaul and device replacement only can be done by trained professional maintenance staff. During operation, insulation protection tools shall be applied. It is strictly prohibited to leave thrum and metal in the machine. Otherwise, there can be dangers of electric shock, fire, and personal and property damage.
2. After replacement of control board, corresponding parameters must be set before operation; otherwise, there can be danger of property damage.

## 1.3 KNOWLEDGE ON OPERATION

### 1.3.1 APPLICATION KNOWLEDGE OF DRIVING GENERAL MOTOR

1. The temperature when driving general motor applied with frequency converter can be a little higher than that of industrial frequency power. With long-term operation at low speed, the operation life of motor can be affected due to the poorer heat dissipation effect. In this case, special frequency converter shall be selected or lighten the motor load.
2. If when the equipment is installed with frequency converter drive, sometimes, there can be resonance due to the natural vibration frequency of mechanical system, please consider about applying flexible coupling and insulation rubber, or applying the function of hopping frequency of the frequency converter, to avoid the resonance point for operation.
3. There can be larger noise when driving general motor applied with frequency converter than that of industrial frequency power. In order to reduce the noise, the carrier frequency of frequency converter can be increased properly.

### 1.3.2 APPLICATION KNOWLEDGE OF DRIVING SPECIAL MOTOR

1. For high-speed motor, if the set frequency of frequency converter is above 120Hz, please conduct combination test with motor, to make sure it can be operated safely.
2. For synchronous motor, there must be correspondences according to the types of motor. Please contract the manufacturer for consultation.
3. Operation of single-phase motor is not applied with frequency converter. Even when input with single phase, there is three-phase output, please apply with three-phase motor.

### 1.3.3 AMBIENT ENVIRONMENT

Application shall be applied in the indoor range with environment temperature of -10 to +45°C, humidity around below 95% (without condensation of moisture), no dust, no direct sunlight, no corrosive gas, no combustible gas, no oil mist, no steam, no water or floating fiber or mental particles; if there is special requirements of clients, please contract the manufacturer for consultation.

### 1.3.4 CONNECTION KNOWLEDGE OF PERIPHERAL EQUIPMENT

1. For the protection of wirings, please configure breaker for wirings on the input side of frequency converter. Please do not apply device with larger capacity than recommendation.
2. If it needs to switch to industrial frequency power and others, when installing electromagnetic contactor on the output side of frequency converter, please switch after frequency converter and motor stop running.
3. When applying with motor thermal relay, if the wiring of motor is too long, sometimes it is affected with the high-frequency current flowing through capacitance distributed with wiring, current below the set value of thermal relay may also cause trip. In this case, please lower the carrier frequency, or apply with output filter.
4. For noise interference, connection filter, magnet ring and shielded wire can be applied as corresponding measures.

### **1.3.5 TRANSPORTATION AND STORAGE**

1. During product handling, please capture the both sides of the bottom of the entity, rather than the cover or parts only.
2. Please do not make the parts of plastic excessive forced, otherwise, there can be falling down or damage.
3. When it is for temporary storage and long-term storage, pay attention to the followings:
  - Try to be packaged in the packing case of our company as the original package for storage.
  - Long-term of storage will lead to the characteristics of electrolytic capacitor worsen, therefore, it shall be powered on every half year at least, and with conduction time more than half an hour, and the input voltage must be risen to the rated value gradually with voltage regulator.

### **1.4 ABANDON CAUTION**

1. Explosion of the electrolytic capacitor: Electrolytic capacitor in the frequency converter may cause explosion while burning.
2. Waste gas of plastic burning: Harmful and toxic gas may be produces while burning the plastic and rubber product of the frequency converter.
3. Disposal methods: Please deal with the frequency converter as industrial waste.

### **1.5 OTHER CAUTIONS**

1. This product shall not be applied for life support device and other application concerning directly with human body safety, otherwise, there can be accident.
2. If serious accident or serious losses caused due to the failure of this product, please install safety device for this product, otherwise, there can be accident.

## 2. PRODUCTION INTRODUCTION

### 2.1 INVERTER MODEL

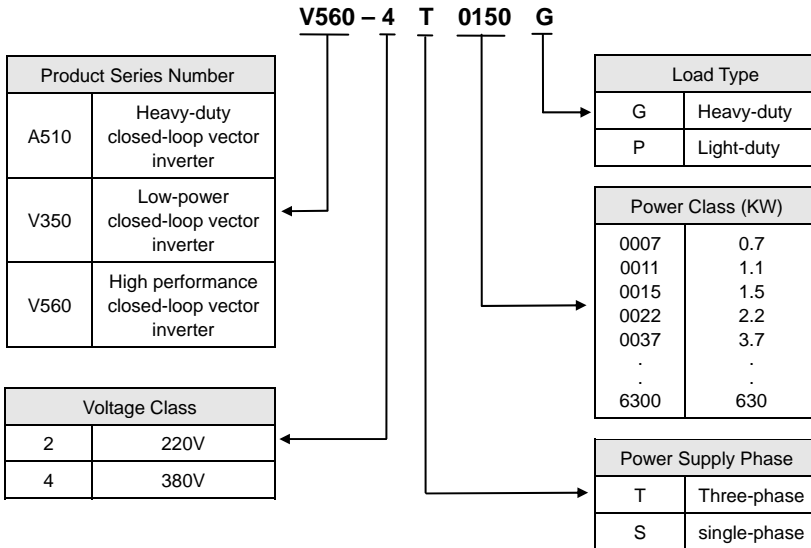

### 2.2 PRODUCT APPEARANCE

- Appearance Type I: Suitable Mode: V560-4T0007G/4T0011P ~ V560-4T0022G/4T0030P

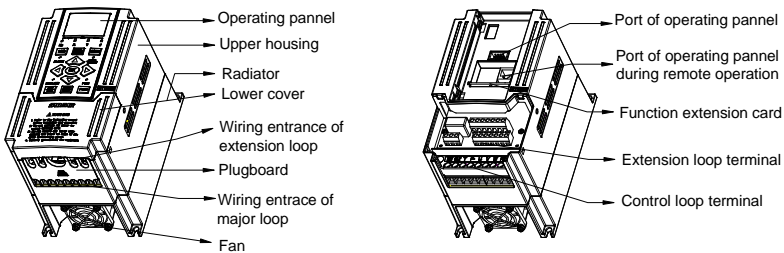

- Appearance Type II: Suitable Mode: V560-4T0030G/4T0040P ~ V560-4T0110G/4T0150P

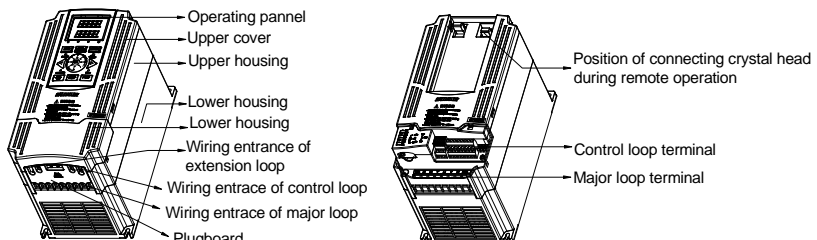

- Appearance Type III: Suitable Mode: V560-4T0150G/4T0185P ~ V560-4T0300G/4T0370P

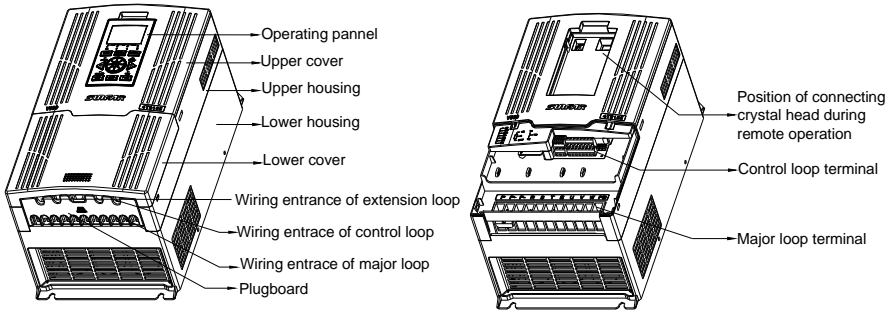

- Appearance Type IV: Suitable Mode: V560-4T0370G/4T0450P ~ V560-4T2000G/4T2200P

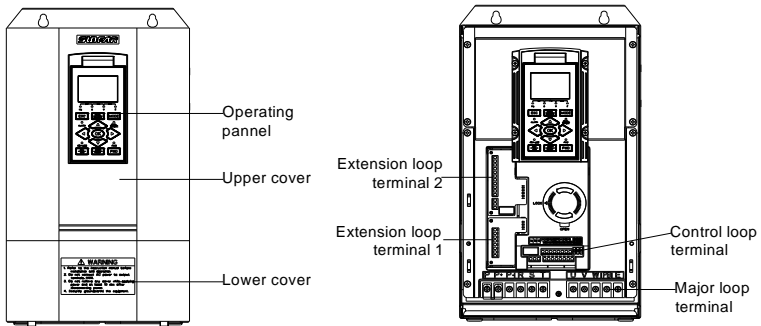

- Appearance Type V: Suitable Mode: V560-4T2200G/4T2500P ~ V560-4T3150G/4T3500P

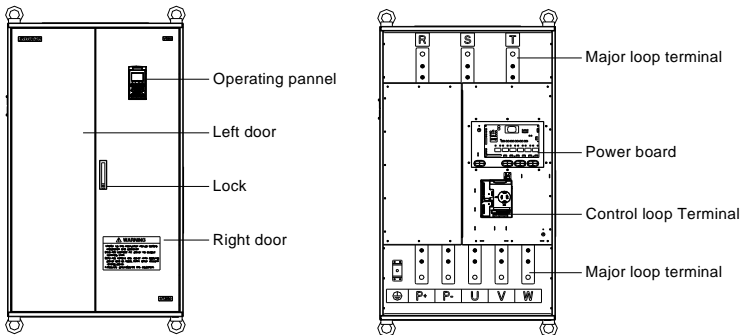

- Appearance Type VI: Suitable Mode: V560-4T3500G/4T4000P ~ V560-4T6300G/4T7000P

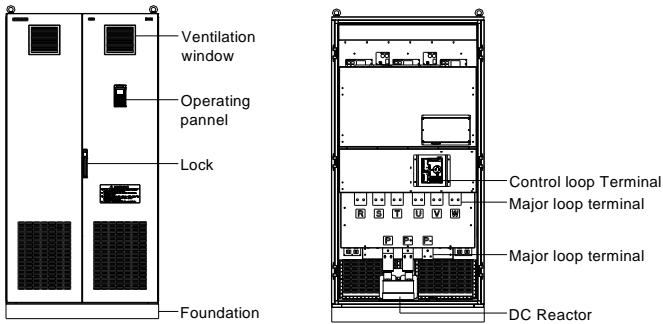

### 2.3 MODEL TABLE

Model	Universal load mode			Steady light load mode		
	Rated capacity (KVA)	Rated current (A)	Adaptive motor (KW)	Rated capacity (KVA)	Rated current (A)	Adaptive motor (KW)
V560-4T0007G/4T0011P	1.5	2.3	0.75	2.0	3.0	1.1
V560-4T0011G/4T0015P	2.0	3.0	1.1	2.4	3.7	1.5
V560-4T0015G/4T0022P	2.4	3.7	1.5	3.6	5.5	2.2
V560-4T0022G/4T0030P	3.6	5.5	2.2	4.9	7.5	3.0
V560-4T0030G/4T0040P	4.9	7.5	3.0	6.3	9.5	4.0
V560-4T0040G/4T0055P	6.3	9.5	4.0	8.6	13.0	5.5
V560-4T0055G/4T0075P	8.6	13.0	5.5	11.2	17.0	7.5
V560-4T0075G/4T0090P	11.2	17.0	7.5	13.8	21	9.0
V560-4T0090G/4T0110P	13.8	21	9.0	16.5	25	11
V560-4T0110G/4T0150P	16.5	25	11	21.7	33	15
V560-4T0150G/4T0185P	21.7	33	15	25.7	39	18.5
V560-4T0185G/4T0220P	25.7	39	18.5	29.6	45	22
V560-4T0220G/4T0300P	29.6	45	22	39.5	60	30
V560-4T0300G/4T0370P	39.5	60	30	49.4	75	37
V560-4T0370G/4T0450P	49.4	75	37	62.5	95	45
V560-4T0450G/4T0550P	62.5	95	45	75.7	115	55
V560-4T0550G/4T0750P	75.7	115	55	98.7	150	75
V560-4T0750G/4T0900P	98.7	150	75	116	176	90
V560-4T0900G/4T1100P	116	176	90	138	210	110
V560-4T1100G/4T1320P	138	210	110	171	260	132
V560-4T1320G/4T1600P	171	260	132	204	310	160
V560-4T1600G/4T1850P	204	310	160	237	360	185
V560-4T1850G/4T2000P	237	360	185	253	385	200

Model	Universal load mode			Steady light load mode		
	Rated capacity (KVA)	Rated current (A)	Adaptive motor (KW)	Rated capacity (KVA)	Rated current (A)	Adaptive motor (KW)
V560-4T2000G/4T2200P	253	385	200	276	420	220
V560-4T2200G/4T2500P	276	420	220	313	475	250
V560-4T2500G/4T2800P	313	475	250	352	535	280
V560-4T2800G/4T3150P	352	535	280	395	600	315
V560-4T3150G/4T3500P	395	600	315	424	645	350
V560-4T3500G/4T4000P	428	650	350	480	730	400
V560-4T4000G/4T4500P	480	730	400	527	800	450
V560-4T4500G/4T5000P	527	800	450	592	900	500
V560-4T5000G/4T5600P	592	900	500	658	1000	560
V560-4T5600G/4T6300P	658	1000	560	737	1120	630
V560-4T6300G/4T7000P	737	1120	630	823	1250	700

## 2.4 PRODUCT TECHNICAL INDEX AND SPECIFICATIONS

Input  Output	Rated voltage frequency	Three phase(4T# series) 380V 50/60Hz		
	Output voltage	4T# series: 0~380 V		
	Output frequency	Low frequency mode: 0.0~300.00Hz; High frequency mode: 0.0~2000.0Hz.		
	Digital input	Standard configuration: 6-circuit digital input (DI), extensible to 16-circuit (optional extension components)		
	Digital output	Standard configuration: 2-circuit digital output (DO)		
	Pulse in and out	0~100.0KHz pulse input, can receive OC or 0~24V level signal (optional)		
	Pulse output	0 -100.0KHz pulse output(optional), PWM output mode can be selected to extend analog output terminal.		
	Analog input	Standard configuration: 0~10V voltage input (AI1); 0~20mA current input (AI2) Standard IO board: -10V~10V voltage input		
	Analog output	Two-circuit 0-10V analog output signal (can be set to 0~10V current output mode)		
	Contact output	Standard one group of AC 250V/2A normally open and closed contacts, extensible 1-6 groups normally open and closed contacts		
Control Characteristics	Control Mode	Closed-loop vector control	Open-loop vector control	V/F control
	Starting torque	0 speed 200%	0 speed 180%	0 speed 180%
	Speed adjustable range	1 : 1000	1 : 200	1 : 100
	Steady speed precision	±0.02%	±0.2%	±0.5%
	Torque control precision	±5%	±5%	--



<b>Control Characteristics</b>	Torque response time	≤ 5ms	≤ 25ms	--
	Frequency resolution	Low frequency mode: 0.01Hz; High frequency mode: 0.1Hz.		
	Frequency precision	Low frequency mode: digital setting--0.01 Hz, Analog setting - highest frequency ×0.1% High frequency mode: digital setting--0.1 Hz, Analog setting - highest frequency ×0.1%		
	Load capacity	Universal load mode: 110% - long-term; 150% - 60s; 180% -5s		
		Steady load mode (capacity increase mode): 105% - long-term; 120% - 60 s; 150% - 1 s		
	Carrier frequency	Three-phase vector composition: 1.5 ~ 12.0KHz		
	Deceleration and acceleration time	0.01 - 600.00Sec. / 0.01 - 600.0Min.		
	Magnetic flux brake	Achieve rapid retarding brake of the motor by increasing the motor's magnetic flux (30-120% allowed)		
	DC brake/band-type rake	DC brake/band-type brake initial frequency: 0.0 - upper limiting frequency, brake/band-type brake injection current 0.0 ~ 100.0%		
Strike frequency	0.0 ~ 50.00Hz			
<b>Typical Function</b>	Multi-segment running	16-segment frequency/speed running, independent setting of the running direction, time and acceleration and deceleration of each segment; 7-segment process PID setting		
	Built-in PID	Two built-in PID controller (process PID, compensation PID), can be either used independently by external equipment or be used to create complicated internal compensation control.		
	Wakening and sleeping	Process PID has simple sleeping and wakening functions.		
	MODBUS communication	Standard MODBUS communication protocol (optional) allowing for flexible parameter reading and mapping		
	Temperature detection	Able to receive detecting signals of PT100 or PTC thermo-sensitive elements, hence allows for over-temperature protection for the motor or external equipment.		
	Dynamic braking	(Standard configuration for models below V560-4T0220G/4T0300P) Actuating voltage: 650~760V, braking ratio: 50~100%		
	General Functions	Power cut restart; Fault self-recovery, motor parameter dynamic/static self-identification. Start enabling, operation enabling, start delay, over current suppression, over voltage/under voltage suppression, V/F custom curve, analog input curve correction, line brake detection, textile machinery disturbance (frequency swing) operation.		
<b>Function Features</b>	Virtual IO terminal	8-circuit one-to-one virtual output and input terminals, allowing for complicated engineering onsite application in an easy way.		
	Position servo and division positioning	Allows for easy servo control and precision positioning of spindle angle.		
	Communication linkage synchronization	Easily allows for synchronized rotation of multiple rotation, and free selection of linkage balance of multiple machines based on current, torque and power, and the position synchronized balance function can ensure zero cumulative error of multi-machine linkage.		

<b>Function Features</b>	Load dynamic balance	Also allows for dynamic balance of multi-machine load (not limited to communication linkage) and able to achieve torque motor characteristics.
	Strong starting torque	For load featuring high inertia and high static friction, super strong starting torque for certain period can be set.
	Setting priority	Users can freely select the priority of various frequency/revolution setting channel; Suitable for combined application for various occasions.
	Setting combinations	Up to hundreds of setting combinations of frequency, revolution and torque.
	Compensation PID	Especially built-in compensation PID, flexibly allowing for tension control, drawing machine control and other special applications.
	Dual motor parameter	With two sets of asynchronous motor parameters, allowing for motor switch even in the mode of vector control.
	Timer	3 built-in timers: 5 kinds of time, 5 kinds of trigger modes, multiple door access signals and working modes, and 7 kinds of output signals.
	Counter	2 built-in counters: Time margin selection, 4 kinds of trigger modes and 7 kinds of output signal
	Macro parameter	Application macro: Allowing for conveniently setting and partially curing multiple common group parameters and simplifying parameter setting for common applications.
		System macro: Allowing for conveniently switching equipment's working mode, and automatically redefining local parameters.
	Parameter testing	Any un-stored parameter tested on site can be stored with one key or abandoned and restored to original value.
	Parameter display	Allowing for automatically shielding parameters of unused functional modules or selectively displaying modified, stored or changed parameters.
<b>Protection Function</b>	Power supply	Under voltage protection and three-phase power supply unbalancing protection
	Running protection	Over current protection, over voltage protection, inverter over temperature protection, inverter overload protection, motor overload protection, output phase lack protection, and module drive protection.
	Equipment abnormality	Current detected abnormality, EEPROM memory abnormality, and abnormal control unit, motor over temperature, MC pull-in fault, and temperature acquisition loop fault.
	Motor connection	Motor not connected, motor's three-phased parameters unbalanced and parameter misidentification.
	Extension card	Detect and protect the extension card for compatibility or conflict.
<b>Environment</b>	Installation environment	Indoor vertical installation, not subjecting to direct sunshine, free of dust, corrosive and flammable gas, oil mist, vapor and free of drips or salt.
	Altitude	0~1000 m. The output current capability drops by 10% for every rise of 1000 m.
	Ambient temperature	Working ambient temperature: -10°C ~ +45°C Storage ambient temperature: -20°C ~ +60°C
	Humidity	Blow 95%, no condensed water
	Vibration	< 20m/s <sup>2</sup>

## 3. INSTALLATION OF FREQUENCY INVERTER

### 3.1 INSTALLATION OF FREQUENCY INVERTER

This series of frequency inverters are wall-mounted or cabinet frequency inverters, which should be installed vertically. In order to be in favor of circulation and heat dissipation, please install the frequency inverter at indoor place with good ventilation. Please refer to 1.3.3 for installation environment. If there is special installation requirement from customer, please contact with manufacturer in advance.

#### 3.1.1 MOUNTING SURFACE

Sometimes, the temperature of cooling fin may rise to around 90℃, so please install the mounting surface at the place which can stand for this temperature rise.



#### 3.1.2 INSTALLATION SPACE

Requirements for installation spacing distance of single frequency inverter are as shown in Figure 3-1-A and Figure 3-1-B. Reserve enough space around the frequency inverter.

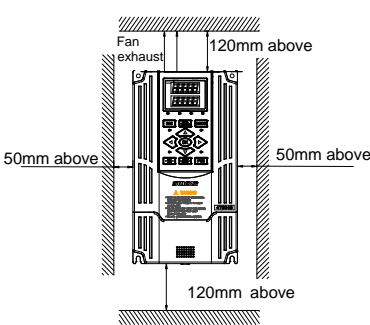

Figure 3-1-A Installation spacing distance (30KW below)

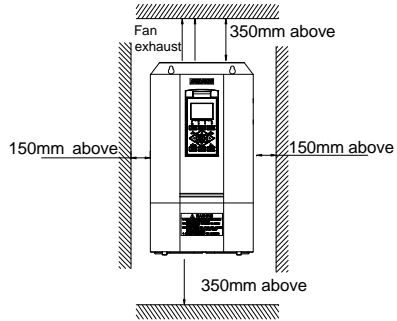

Figure 3-1-B Installation spacing distance (37KW above)

#### 3.1.3 MULTIPLE INSTALLATIONS

If install more than 2 sets of frequency inverters in device or control cabinet, please conduct parallel installation in principle as shown in Figure 3-3. If there is no choice but vertical installation, please consider setting partition plate as shown in Figure 3-2, to make no influence on upper frequency inverter from lower frequency inverter.

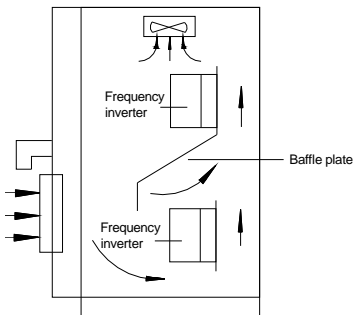

Figure 3-2 Installation spacing between upper and lower frequency inverters

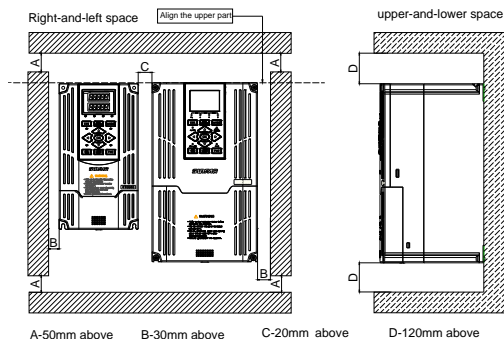

Figure 3-3 Installation sizes of right and left frequency inverters (4.0KW above)





- Horizontally close installation is only for 4.0KW below, and -10°C ~ 45°C environmental temperature.
- For parallel installation of frequency inverters with different sizes, please carry out installation after aligning the upper parts of all the frequency inverters, thus to be in favor of changing cooling fan.
- Please don't install frequency inverter in the environment with tattered cotton yarn and damp dust which may cause blockage of cooling fin. If necessary to operate in such environment, please install in the control cabinet which can keep tattered cotton yarn out.
- If necessary to install at the place with more than 1000m height above sea level, please de-rate operation. See 2.4 product technical indexes and specifications for details.

### 3.2 ASSEMBLY OF OPERATION PANEL

The name of operation panel, model, code and applicable inverter, as follows:

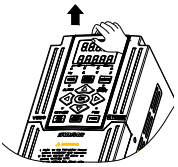
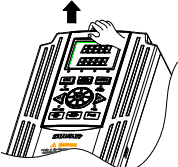
name	Double line LED panel	Double line LED operation panel (shuttle type)	Double line LED standard operation panel
model	DPNL350EM	DPNL360EB	DPNL360EA
code	050M007033701	050M007360004	050M007360003
Standard model	Apply to the inverter below V560-4T0022G/4T0030P	Apply to V560-4T0030G/4T0040P ~ V560-4T0300G/4T0370P	Apply to the inverter above V560-4T0370G/4T0450P
appearance			

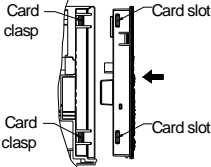
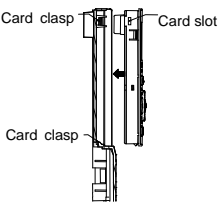
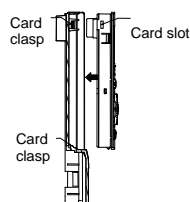
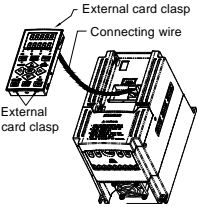
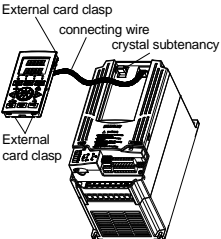
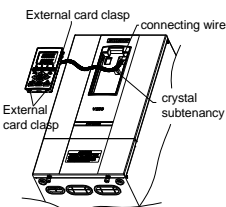
<p>disassembly</p>	<p>Put middle finger in the finger hole site front of the operation panel, slightly lift the panel up.</p> 	<p>Put middle finger in the finger hole site front of the operation panel, slightly lift the panel up.</p> 	<p>Put middle finger in the finger hole site front of the operation panel, slightly lift the panel up.</p> 
<p>installation</p>	<p>After the alignment of panel and its slot position, push the panel down evenly.</p> 	<p>Joint the fixed mouth of hook at the bottom of operation panel and spring plate under panel base, then only push the panel inward.</p> 	<p>Joint the fixed mouth of hook at the bottom of operation panel and spring plate underpanel base, then only push the panel inward.</p> 
<p>Extend external connection</p>	<p>Disassemble the operation panel and make the extension cord as follows.</p> 	<p>Disassemble the operation panel, take crystal joint and put it in the designated position in case of the lost. The extension cord as follow.</p> 	<p>Disassemble the operation panel, take crystal joint and put it in the designated position in case of the lost. The extension cord as follow.</p> 



- It shall employ extension cable or LAN cable available (straight cable) in the market.
- Extension cable shall not exceed 15 meters; Shielding layer is connected with ground terminal of frequency inverter. Please select fittings of remote operation panel for more than 15 meters.
- Do not carry out wiring horizontally close to power line.
- Panel shall be fastened on stable fixed surface or work bench so as to avoid damage.

### 3.3 DISASSEMBLY AND INSTALLATION OF TERMINAL COVER

#### 3.3.1 DISASSEMBLY AND INSTALLATION OF PLASTIC COVER PLATE

- Disassembly:

Put finger on the handle slot at the bottom of cover plate (the position of clasp as Figure 3-4), and forcibly lift it upward until the card clasps between cover plate and shell break away, then pull the cover plate down can disassemble the shell. Shown as Figure 3-4.

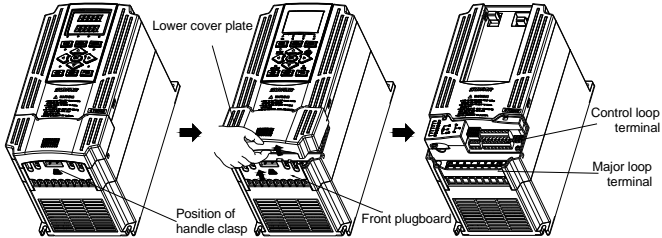

Figure 3-4 Disassembly and installation schematic diagram of plastic terminal cover

- Installation:

Slant cover plate into about 15°, then insert the fixed stator at the top of cover plate into fixed slot on shell. Forcibly press the cover plate down until heard a click, which means the cover plate has been in place.

#### 3.3.2 DISASSEMBLY AND INSTALLATION OF SHEET-METAL COVER PLATE

Disassembly and installation of sheet-metal cover plate are as shown in Figure 3-5.

- Disassembly:

- Undo the two thumb screws at the bottom of cover plate;
- Translate the cover plate outward along direction of icon then can dismantle it.

- Installation:

- Place the cover plate down parallel to the chassis, to make cover plate just seize up the both sides of chassis;
- Push cover plate forward along direction of icon, to make the stator at the top of cover plate insert into the fixed slot on shell;
- Tighten up the two thumb screws at the bottom of cover plate.

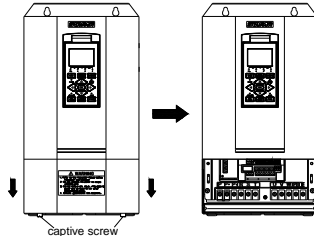
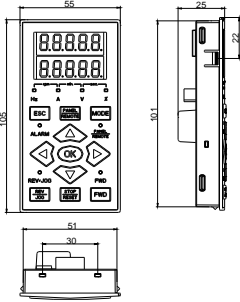
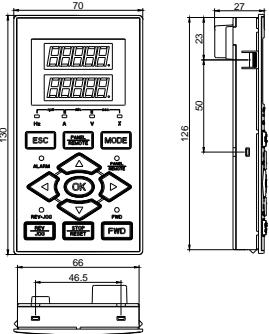
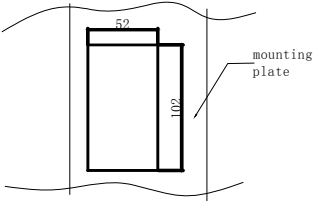
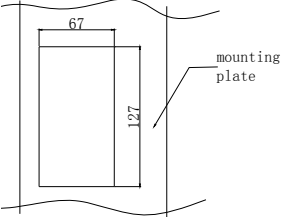
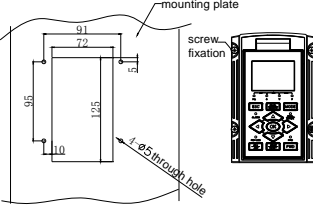

Figure 3-5 Schematic diagram of disassembly and installation of sheet-metal cover plate

### 3.4 INSTALLATION SIZE OF PANEL(Operation panel is optional in accordance to the installation need.)

name	Double line LED panel	Double line LED standard operation panel/ double line LED operation panel (shuttle type)
Installation size		
external installation without the tray	<p>The trepanning of mounting plate as follow; size : 102*52</p> 	<p>The trepanning of mounting plate as follow; size : 127*67</p> 
External installation with a tray	<p>No such connection</p>	<p>The trepanning of mounting plate as follow</p> 

### 3.5 DISASSEMBLY AND INSTALLATION OF EXPANSION BOARD

Please refer to Figure 3-6 for disassembly and installation of expansion board.

- Installation:
  1. Place expansion board in direction as shown in figure, press down until good connection between expansion board and socket of control panel;
  2. Tighten the fastening screw M3 at the left upper corner of the expansion card
  
- Disassembly:
  1. Loosen the fastening screw M3 at the left upper corner of the expansion card;
  2. Pull expansion board up (as shown in Figure 3-16) out from the socket of control panel.

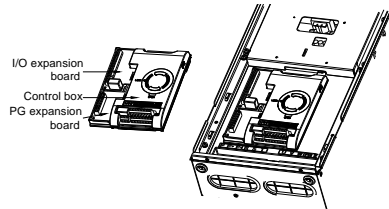

Figure 3-6 Schematic diagram of installation and disassembly of expansion board

### 3.6 INSTALLATION AND DISASSEMBLY OF FUNCTION BOARD

#### 3.6.1 The installation of type I function card

Function board is installed on control panel with utilization of extension cord. As shown in Figure 3-7-A.

Apply to the inverter model above V560-4T0030G/4T0040P.

- Installation:
  1. After making the triangle mark on cylindrical cover plate direct to "open", put index finger or middle finger into the hole to push upward, then can take the circular cover plate out;
  2. Make the socket of function board direct to the pin of control board, and then slightly press it down until good contact;
  3. Get cylinder cover plate on and rotate clockwise to make the triangle on it direct to "lock".

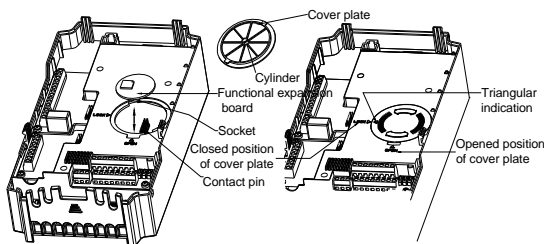

Figure 3-7-A Schematic diagram of installation and disassembly of type I function board

- Disassembly:
  1. Clockwise rotate cylinder to make the triangle on it direct to "open", put index finger or middle finger into the hole, push up then can take the cylindrical cover plate out
  2. Slightly pull the pin of control board up out from function board then can take it out.



### 3.6.2 installation of type II function card

Install the function card on the control panel through the guide slot and USB plug, as 3-7-B demonstrate . apply to the inverter model below V560-4T0030G/4T0040P.

Installation:

- ① Take the keyboard out.
- ② Zero in the square functional expansion card at guiding slot, keep the USB plug downward and use the index finger or the middle finger to press it into the bottom.

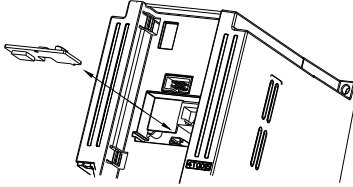
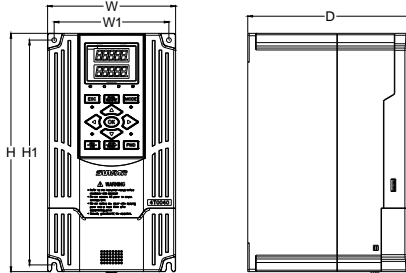

Figure 3-7-B installation and disassemble of type II function card

## 3.7 INSTALLATION SIZE OF FREQUENCY INVERTER

Type I suitable model: V560-4T0007G/4T0011P ~ V560-4T0300G/4T0370P



Type II suitable model: V560-4T0370G/4T0450P ~ V560-4T2000G/4T2200P

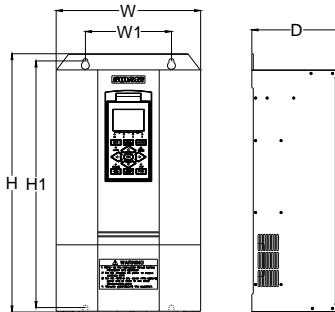

Type III suitable model: V560-4T2200G/4T2500P ~ V560-4T3150G/4T3500P

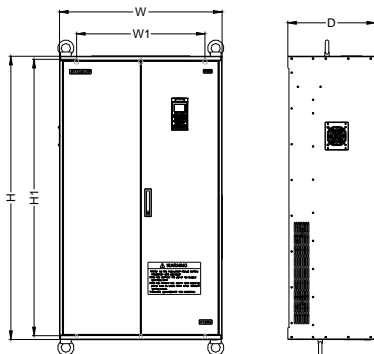

Type IV suitable model: V560-4T3500G/4T4000P ~ V560-4T6300G/4T7000P

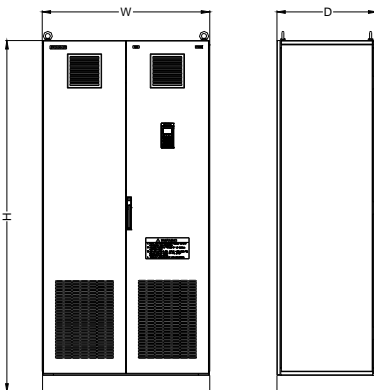

<b>W</b>	Backboard width
<b>W1</b>	The distance between mounting hole
<b>H</b>	The height of backboard
<b>H1</b>	The distance between mounting hole
<b>D</b>	The distance between backboard and headboard

Specific installation sizes of V560 series frequency inverters as listed below:

Model of frequency inverter (Three-phase 380V)	W1 (mm)	W (mm)	H1 (mm)	H (mm)	D (mm)	Specification of screw
V560-4T0007G/4T0011P	87	97	152	162	130	M4
V560-4T0011G/4T0015P						
V560-4T0015G/4T0022P	95	105	190	200	146	M4
V560-4T0022G/4T0030P						
V560-4T0030G/4T0040P	121	135	234	248	175	M4
V560-4T0040G/4T0055P						
V560-4T0055G/4T0075P	146	160	261	275	179	M5
V560-4T0075G/4T0090P						
V560-4T0090G/4T0110P	169	180	290	305	179	M5
V560-4T0110G/4T0150P						
V560-4T0150G/4T0185P	160	210	387	405	202	M6
V560-4T0185G/4T0220P						
V560-4T0220G/4T0300P	160	250	422	445	216	M8
V560-4T0300G/4T0370P						
V560-4T0370G/4T0450P	180	298	525	564	249	M8
V560-4T0450G/4T0550P						
V560-4T0550G/4T0750P	260	350	564	606	277	M8
V560-4T0750G/4T0900P	293	400	685	725	271	M10
V560-4T0900G/4T1100P						
V560-4T1100G/4T1320P	360	516	695	735	283	M10
V560-4T1320G/4T1600P	360	516	725	765	302	M10
V560-4T1600G/4T1850P	360	540	862	890	323	M10
V560-4T1850G/4T2000P	500	640	974	1000	323	M10
V560-4T2000G/4T2200P						
V560-4T2200G/4T2500P	560	730	1073	1100	370	M10
V560-4T2500G/4T2800P						
V560-4T2800G/4T3150P	600	756	1290	1322	410	M10
V560-4T3150G/4T3500P						
V560-4T3500G/4T4000P	--	900	--	2100	600	--
V560-4T4000G/4T4500P						
V560-4T4500G/4T5000P	--	1000	--	2100	600	--
V560-4T5000G/4T5600P						
V560-4T5600G/4T6300P	--	1200	--	2100	600	--
V560-4T6300G/4T7000P						

## 4. WIRING OF FREQUENCY INVERTER

### 4.1 CAUTIONS OF WIRING

- Make sure middle circuit breaker is connected between the frequency inverter and power supply to provide a safely trip if the frequency inverter is faulty.
- In order to reduce electromagnetic interference, please connect surge absorber on the coil of electromagnetic contactor, relay and etc. in the surrounding circuit of the frequency inverter.
- Please use shielded wire of above  $0.3\text{mm}^2$  for the wiring of such analog signals as frequency setting terminal and instrument loop, etc. The shielding layer shall be connected on the grounding terminal of the frequency inverter (keep single-end-earthed shielding layer) with wiring length of less than 30m.
- The stranded wire or shielded wire of above  $0.75\text{mm}^2$  shall be selected for the wiring of input and output loop of relay.
- The control wire shall be separated from the power line of major loop; it shall be at a distance of above 10cm for parallel wiring and vertical for cross wiring.
- All the leading wires shall be completely fastened with the terminal to ensure good contact. The leading wires of major loop shall be adopted cables or copper bar. When using cables, wiring must not be carried out until they are cold pressed or welded well by lug plate with corresponding section.
- The pressurization of all the leading wires shall be in compliance with the voltage class of the frequency inverter.
- Please reliably ground the frequency inverter and motor locally.



- Absorption capacitor or other RC absorbers shall not be installed at U, V and W output end of the frequency inverter, as shown in Figure 4-1.

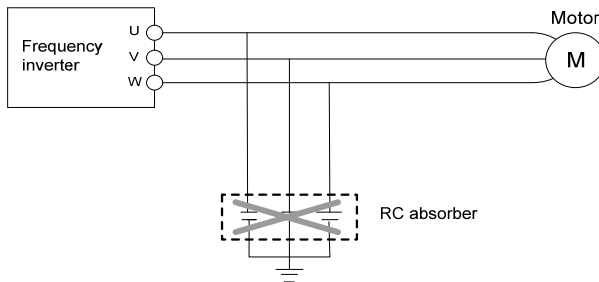

Figure 4-1 RC absorbers shall not be connected at output end

## 4.2 CONNECTION OF OPTIONAL FITTINGS AND FREQUENCY INVERTER

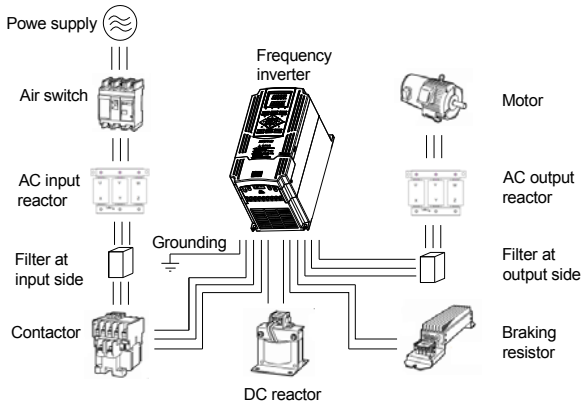

Figure 4-2 Wiring of frequency inverter

- 1) Power supply: The power supply shall be in accordance with the specification of input power supply designated by this operating manual.
- 2) Air switch:
  - When the frequency inverter is maintained or not in use for a long time, the air switch will separate the frequency inverter from the power supply;
  - When the input side of the frequency inverter has failures like short circuit, the air switch can protect.
- 3) AC input reactor: When the interaction of higher harmonic between the frequency inverter and power supply cannot meet the requirements after serious wave form distortion of power grid or the frequency inverter is equipped with DC reactor, the AC input reactor can be added. The AC input reactor can improve the power factors at input side of the inverter and reduce the influence caused by unbalanced voltage of three-phase power supply.
- 4) Filter at input side: EMI filter can be selected to restrict the high-frequency noise interference from the power cord of the frequency inverter.
- 5) Contactor: It can cut off the power supply when the system protective function acts to prevent failure expanding.
- 6) DC reactor: In order to defend the influence of power supply to frequency inverter, protect the inverter and restrict higher harmonic, DC reactor shall be equipped under the following conditions:
  - When the power supply of frequency inverter has switch LBMJ on the node or with silicon controlled phase control load, the voltage jump of the grid resulted from reactive transient caused by capacitor switching and harmonic and grid wave form gap caused by phase control load may damage the input rectifying circuit of the frequency inverter.
  - When the three-phase power supply of the frequency inverter is unbalanced;
  - When the power factors at the input end of the frequency inverter are required to improve.



- Standard built-in DC reactor for V260-4T0750G/4T0900P model and above.

- 7) Filter at output side: EMI filter can be selected to restrict the interference noise generated at the output side of the inverter and wire leakage current.

- 8) AC output reactor: When the wiring from the frequency inverter to the motor is longer (exceeding 20m), it can restrict radio interference and leakage current.
- 9) Braking resistor: Improve the braking capacity of frequency inverter to avoid overvoltage failure when slowing down.

The specification of recommended electric appliances is as follows:

Model of frequency inverter	Adaptive motor (KW)		wire gauge (major loop) (mm <sup>2</sup> )	Air circuit breaker (A)	Electromagnetic contactor (A)
	General loads	Load for fan and water pump			
V260-4T0007G/4T0011P	0.75	1.1	1.	10	9
V260-4T0011G/4T0015P	1.1	1.5	1.5	16	12
V260-4T0015G/4T0022P	1.5	2.2	2.5	16	12
V260-4T0022G/4T0030P	2.2	3.0	4	16	12
V260-4T0030G/4T0040P	3.0	4.0	4	20	16
V260-4T0040G/4T0055P	4.0	5.5	4	25	16
V260-4T0055G/4T0075P	5.5	7.5	6	32	22
V260-4T0075G/4T0090P	7.5	9.0	6	40	32
V260-4T0090G/4T0110P	9.0	11	10	50	32
V260-4T0110G/4T0150P	11	15	10	63	32
V260-4T0150G/4T0185P	15	18.5	10	63	38
V260-4T0185G/4T0220P	18.5	22	16	80	45
V260-4T0220G/4T0300P	22	30	16	100	63
V260-4T0300G/4T0370P	30	37	25	125	75
V260-4T0370G/4T0450P	37	45	25	160	85
V260-4T0450G/4T0550P	45	55	35	200	110
V260-4T0550G/4T0750P	55	75	50	225	140
V260-4T0750G/4T0900P	75	90	70	250	170
V260-4T0900G/4T1100P	90	110	70	315	205
V260-4T1100G/4T1320P	110	132	95	400	250
V260-4T1320G/4T1600P	132	160	95	400	330
V260-4T1600G/4T1850P	160	185	150	630	330
V260-4T1850G/4T2000P	185	200	150	630	400
V260-4T2000G/4T2200P	200	220	185	630	400
V260-4T2200G/4T2500P	220	250	185	800	500
V260-4T2500G/4T2800P	250	280	240	800	500
V260-4T2800G/4T3150P	280	315	240	1000	630
V260-4T3150G/4T3500P	315	350	300	1250	630
V260-4T3500G/4T4000P	350	400	300	1250	780
V260-4T4000G/4T4500P	400	450	400	1600	780
V260-4T4500G/4T5000P	450	500	400	1600	900
V260-4T5000G/4T5600P	500	560	450	1800	1000
V260-4T5600G/4T6300P	560	630	450	1800	1200
V260-4T6300G/4T7000P	630	700	500	1800	1300



- The power of adaptive motor can be increased by one power grade when V260 series frequency inverter is connected with loads for fans and water pumps compared with that for connecting with general loads.

Main loop screw specification/ tightening torque, as listed below

VFD model	Screw specification	Tightening torque(N*m)	Recommended lug model no
V260-4T0007G/4T0011P	M3.5	0.7~0.9	PTV1.25-9
V260-4T0011G/4T0015P	M3.5	0.7~0.9	PTV1.25-9
V260-4T0015G/4T0022P	M3.5	0.7~0.9	PTV1.25-9
V260-4T0022G/4T0030P	M3.5	0.7~0.9	PTV2-9
V260-4T0030G/4T0040P	M4	1.2~1.5	RNY2-4S
V260-4T0040G/4T0055P	M4	1.2~1.5	RNY2-4S
V260-4T0055G/4T0075P	M4	1.2~1.5	RNY5.5-4S
V260-4T0075G/4T0090P	M4	1.2~1.5	RNY5.5-4S
V260-4T0090G/4T0110P	M4	1.2~1.5	RNY5.5-4S
V260-4T0110G/4T0150P	M4	1.2~1.5	RNY5.5-4S
V260-4T0150G/4T0185P	M5	2~2.5	RNY8-5S
V260-4T0185G/4T0220P	M5	2~2.5	RNY8-5S
V260-4T0220G/4T0300P	M6	4~6	RNY14-6
V260-4T0300G/4T0370P	M6	4~6	RNY14-6
V260-4T0370G/4T0450P	M8	9~11	T25-8
V260-4T0450G/4T0550P	M8	9~11	T35-8
V260-4T0550G/4T0750P	M8	9~11	T50-8
V260-4T0750G/4T0900P	M10	18~23	T70-10
V260-4T0900G/4T1100P	M10	18~23	T70-10
V260-4T1100G/4T1320P	M10	18~23	T95-10
V260-4T1320G/4T1600P	M10	18~23	T120-10
V260-4T1600G/4T1850P	M10	18~23	T150-12
V260-4T1850G/4T2000P	M10	18~23	T150-12
V260-4T2000G/4T2200P	M12	25~30	T185-12
V260-4T2200G/4T2500P	M12	25~30	T185-12
V260-4T2500G/4T2800P	M12	25~30	2*T120-12
V260-4T2800G/4T3150P	M16	40~50	T240-16
V260-4T3150G/4T3500P	M16	40~50	T300-16
V260-4T3500G/4T4000P	M12	25~30	2*T185-12
V260-4T4000G/4T4500P	M12	25~30	2*T240-12
V260-4T4500G/4T5000P	M12	25~30	2*T240-12
V260-4T5000G/4T5600P	M12	25~30	4*T185-12
V260-4T5600G/4T6300P	M16	40~50	4*T185-12

V260-4T6300G/4T7000P	M16	40~50	4*T185-12
General control board/extension card connection terminal			
General control terminal	Screw specification	Tightening torque(N*m)	Recommended lug model no
control board/extension card terminal	M2	0.1~0.2	E0.5-6
control board/extension card terminal	M3	0.3~0.4	E0.75-6

Lug model no	E(mm)	D(mm)	d(mm)	W(mm)	B(mm)	L(mm)
T series	T25-8	8.3	9.1	6.7	13	32
	T35-8	8.3	11	8.6	16.7	37
	T50-8	8.3	12.4	9.5	18	41
	T70-10	10.3	15	12	22.5	52.5
	T95-10	10.3	17	13.4	25	55
	T120-12	12.7	19	15	27	60
	T150-12	12.7	21.2	16.5	30	67
	T185-12	12.7	23	19	34	73
	T240-12	12.7	26.5	21	38	91.5
	T240-16	16.5	26.5	21	38	91.5
	T300-16	16.5	30	24.5	43	98

Lug model no	d2(mm)	W(mm)	F(mm)	L(mm)	H(mm)	d1(mm)	D(mm)	T(mm)
RNY series	RNY2-4S	4.3	6.6	7.9	22.2	11	2.3	0.8
	RNY5.5-4S	4.3	7.2	5.9	22.5	13	3.4	1
	RNY8-5S	5.3	8.8	9.3	29.7	16	4.5	1.2
	RNY14-6	6.5	16	14.5	43.5	21.5	5.4	1.4

Lug model no	W(mm)	F(mm)	L(mm)	H(mm)	d1(mm)	D(mm)	T(mm)
PVT/E series	PTV1.25-9	1.9	9	19	10	1.7	0.8
	PTV2-9	1.9	9	19	10	2.3	0.8



	E0.5-6	1.1	6	12	6	1	2.6	/
	E0.75-6	1.1	6	12.3	6.3	1.2	2.8	/

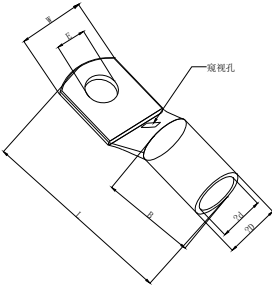

T series

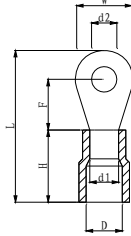

RNY series

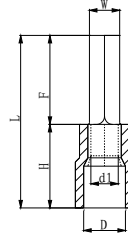
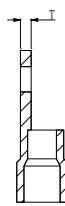

PVT/E series

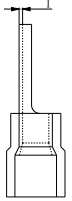

### 4.3 WIRING OF CONTROL TERMINAL

#### 4.3.1 WIRING OF CONTROL PANEL STANDARD TERMINAL CON1、CON2、CON3、CON4

**Type I:** CON3 and CON4 terminals

suitable model: inverter model below  
V260-4T0022G/4T0030P

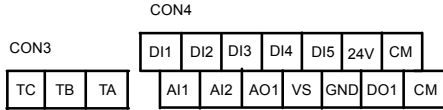

**Type II:** CON1 and CON2 terminals

suitable model: inverter model above  
V260-4T0030G/4T0040P

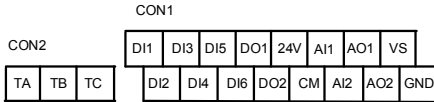

#### 4.3.2 FUNCTION DESCRIPTION OF CONTROL TERMINAL

Type	Label of terminal	Name	Function description of terminal	Specification
Control terminal	DI1—CM	Multifunctional input terminal DI1	6 ways of programmable switching value input terminal can be selected 99 kinds of operational control commands by function code in F3.0 group by programming. See Reference Table for Input Function Selection of Multifunctional Terminal for detail.	Optical coupler isolated input : 24Vdc /5mA Doorsill voltage : <16V Bandwidth < 1MHZ
	DI2—CM	Multifunctional input terminal DI2		
	DI3—CM	Multifunctional input terminal DI3		
	DI4—CM	Multifunctional input terminal DI4		
	DI5—CM	Multifunctional input terminal DI5		
	DI6—CM	Multifunctional input terminal DI6		
Operating status output	CM	Common terminal of input/output terminal	2 ways of programmable open collector output and 1 way of programmable relay output terminal can be selected 71 kinds of operating status output by the function code in F3.1 group by programming. See Reference Table for Monitor Unit Variables for detail.	Maximum load current is 150mA; The highest withstand voltage is 24V.
	DO1—CM	Multifunctional output terminal DO1		
	DO2—CM	Multifunctional output terminal DO2		
	TA	Multifunctional relay output TA-TB normally closed TA-TC normally open		Contact capacity: AC250V/2A
	TB			
TC				
Power supply	CM	+24V power supply reference place	Power supply of switching value terminal	Maximum output current:100mA
	24V	+24V power supply		
Analog	AI1—GND	Analog input AI1	Select input voltage range, polarity	Input voltage:

Type	Label of terminal	Name	Function description of terminal	Specification
input	AI2—GND	Analog input AI2	and other functions with function code in F4 Group.	0-10V, Input impedance: 100K Input current: 0-20mA
Analog output	AO1—GND	Multifunctional analog output AO1	The programmable voltage/current signal output terminal has 45 kinds of monitoring status to be selected by programming. See Reference Table for Monitor Variables for detail. JP1 and JP2 (see DIP Switch Jumper Selection in 4.3.6 for detail) are selected current/voltage output	Current output: 0-20mA Capacity 40Mw, Input current impedance: 0~300Ω
	AO2—GND	Multifunctional analog output AO2		
Power supply	GND	Common terminal of analog signal	Supply +10V/10mA or +5V/50mA power outward	Voltage output: 0-10V
	VS—GND	+10V/5V power supply		Selection of JP3 (see DIP Switch Jumper Selection in 4.3.6 for detail)

### 4.3.3 CAUTIONS TO THE WIRING OF CONTROL TERMINAL

Please pay attention to separate the wiring of control wire and major loop. See section 1.2 for detail.

### 4.3.4 DESCRIPTION OF DIP SWITCH ON CONTROL PANEL

#### 1. One DIP switch have 2 grades

suitable model: inverter model below V260-4T0022G/4T0030P

##### 1) JP3

V grade : Export 0-10V voltage signal from the AO terminal

A grade: Provide 0-20mA current signal from AO terminal

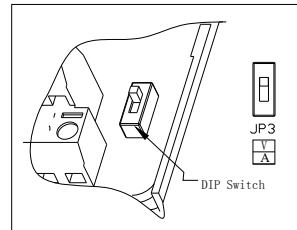

#### 2. Three DIP switches have 3 grades

suitable model: inverter model above V260-4T0030G/4T0040P

##### 1) JP1

VO1 grade: AO1 terminal output voltage signal

OFF grade: AO1 terminal is in suspended status

CO1 grade: AO1 terminal output current signal

##### 2) JP2

VO2 grade: AO2 terminal output voltage signal

OFF grade: AO2 terminal is in suspended status

CO1 grade: AO2 terminal output current signal

##### 3) JP3

5V grade: VS terminal provides 5V voltage signal outward

OFF grade: VS terminal is in suspended status

10V grade: VS terminal provides 10V voltage signal outward

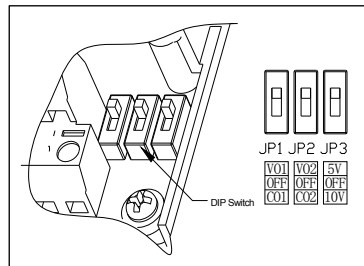

## 4.4 WIRING OF MAJOR LOOP TERMINAL

### 4.4.1 TERMINAL FUNCTIONS

Terminal symbols	Functions	Terminal symbols	Functions
P+	DC side voltage positive terminal	P	DC reactor can be connected between P and P+
P-	DC side voltage negative terminal, Bus voltage input terminal of DC braking unit can be connected between P+ and P-.	PB	DC braking resistor can be connected between P+ and PB
R, S, T	Connect three-phase AC power supply of grid	U, V, W	Connect three-phase AC motor
E	Grounding terminal	--	--

### 4.4.2 WIRING OF MAJOR LOOP TERMINAL AND TERMINAL BLOCKS

**Type I major loop terminal** Applicable type: V260-4T0007G/4T0011P ~ V260-4T0022G/4T0030P

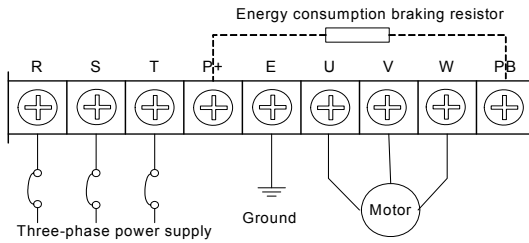

**Type II major loop terminal** Applicable type: V260-4T0030G/4T0040P ~ V260-4T0040G/4T0055P

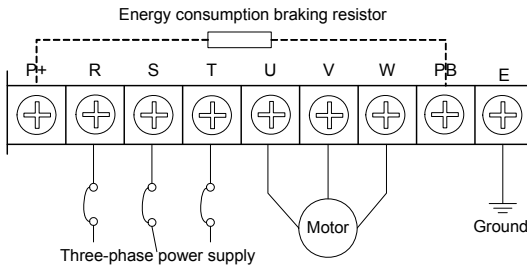

**Type III major loop terminal** Applicable type: V260-4T0055G/4T0075P ~ V260-4T0110G/4T0150P

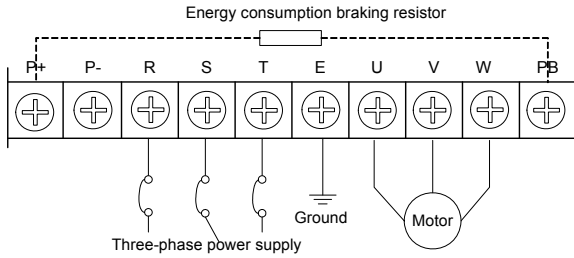

**Type IV major loop terminal** Applicable type: V260-4T0150G/4T0185P ~ V260-4T0185G/4T0220P

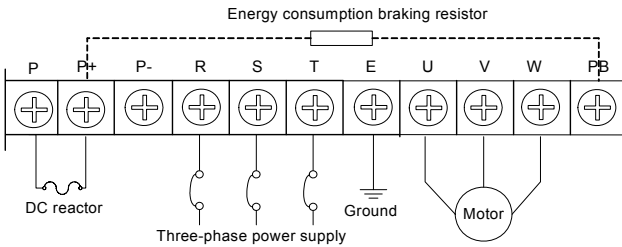

**Type V major loop terminal** Applicable type: V260-4T0220G/4T0300P

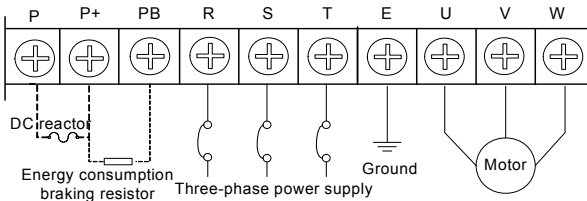

**Type VI major loop terminal** Applicable type: V260-4T0220G/4T0300P

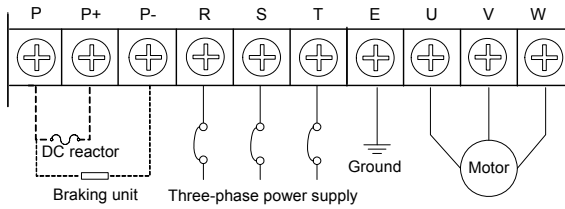

**Type VII major loop terminal** Applicable type: V260-4T0370G/4T0450P ~ V260-4T0450G/4T0550P

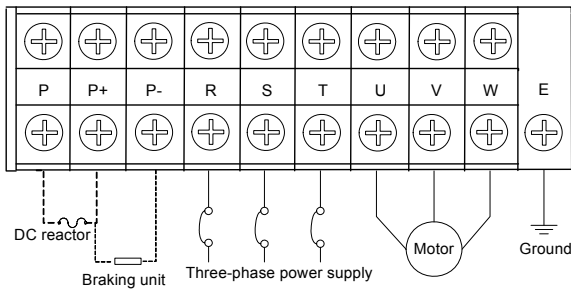

**Type VIII major loop terminal** Applicable type: V260-4T0550G/4T0750P

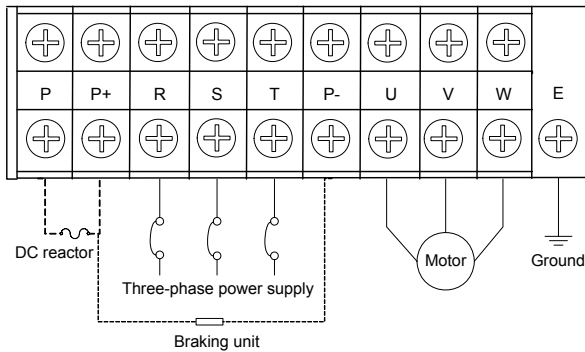

**Type IX major loop terminal** Applicable type: V260-4T0750G/4T0900P ~ V260-4T2000G/4T2200P

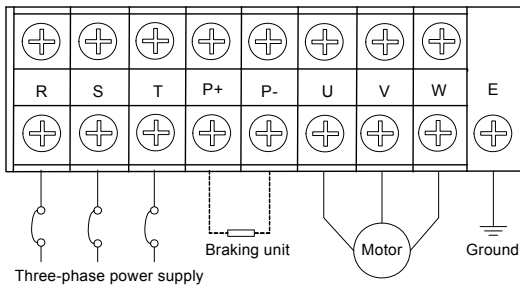

**Type X major loop terminal** Applicable type: V260-4T2200G/4T2500P ~ V260-4T3150G/4T3500P

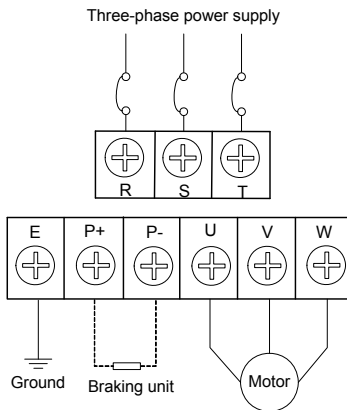

**Type XI major loop terminal** Applicable type: V260-4T3500G/4T4000P ~ V260-4T6300G/4T7000P

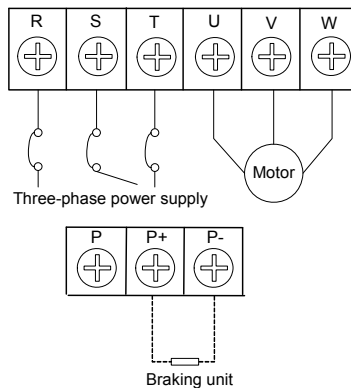

### 4.5 WIRING CONNECTION OF BASIC OPERATION

Applicable type: V260-4T0007G/4T0011P ~ V260-4T6300G/4T7000P

(Built in brake unit in the inverter below V260-4T0220G/4T0300P)

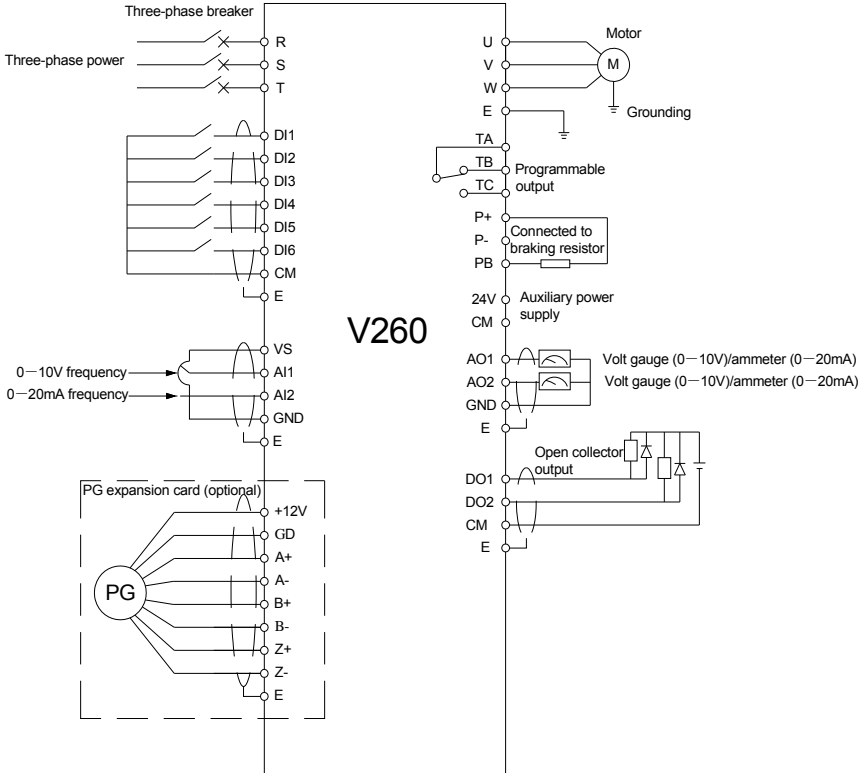

Figure 4-3 Basic wiring diagram for V260 series frequency inverter







## 5. OPERATION AND SIMPLE RUNNING OF FREQUENCY INVERTER













### 5.1 BASIC FUNCTION OF PANEL

The panel of the frequency inverter mainly has two functions apart of basic starting and stopping control: monitoring of parameters for operating status and query and modification of internal parameters. Accordingly, the operation panel is divided into two operating modes: monitoring mode and parameter modification/query mode.

At the beginning of energizing, the main display column presets “sunfr” static display characters and shifts out “sunfr” characters from right to left and recovers normal display about 3 seconds later. At the same time, the auxiliary display column displays the serial number of the frequency inverter statically such as “V-560” and displays the model information of the frequency inverter except “T, S” 3 seconds later such as “4.0037” and displays normally 3 seconds later. At this time, the operating parameters displayed in the operation panel are determined by the internal parameters of the frequency inverter [F0.0.12], [F0.0.13]. The operation panel will return normal monitoring mode at any status if there is no keying operation within 1 minute. (See Chapter 3 for the appearance of the operation panel).

**Table 5-1 Functions of Keys**

Items		Functions
Display function	Main digital display	Display the current operating status parameters and setting parameters of the frequency inverter
	Auxiliary digital display	Display the current operating status parameters and setting parameters of the frequency inverter
	A, Hz, V, %	A, Hz, V displays the corresponding measurement unit of the data of the main digital display. % displays compound unit The compound unit indicator is defined as follows: Hz + A = RPM ; V + % = Sec. ; A + V = Min.
	FWD、REV	Indicator for operating status, its flicker shows the frequency inverter is in F/R operation and has voltage output.
	PANEL/REMOTE	The indicator is off: the external terminal command is valid; the indicator is on: the operation panel command is valid; the indicator is flashing: the communication interface (or expanded communication board or expanded function board) command is valid.
	ALARM	The indicator is on: the frequency inverter is in warning status. It shall check up and eliminate abnormalities; otherwise, the frequency inverter may be faulty and shut down.
Keyboard function		<b>Forward operation command key.</b> Press this key to send forward operation command when the operation command channel of the frequency inverter is set as operation panel control ([F0.3.33] or [F0.3.34]=0).
		<b>Reverse/inching operation command key.</b> Press this key to send reverse operation command when the reverse function ([FF.4.42=# # 0]) is selected and the operation command channel of the frequency inverter is set as operation panel control ([F0.3.33] or [F0.3.34]=0) ; and press this key to send inching operation command when inching function ([FF.4.42=# # 1]) is selected.
		<b>Stop/reset key.</b> When this key is pressed in operating status, the frequency inverter will shut down as per set mode; and when pressing this key in fault conditions, the frequency inverter will reset and return to normal stopped status.  Key can be locked or functions can be changed by users (refer to Functional Parameter F0.011).

		<b>Return key.</b> At any status, it will return to the status of last level till normal monitoring mode by pressing this key.
		<b>Mode key.</b> Switch display function parameter set and monitoring parameter set in parameter modification status. The corresponding "EROM stored value", "value at this time of energizing" and "panel backup value" of the current function code will be displayed at auxiliary display column in turn by pressing this key.
		<b>Data modification key.</b> Used to modify function code or parameter. If digital setting mode is set currently, the digital setting value can be modified directly by using this key in normal monitoring mode.
		<b>Left shift key.</b> At any status using   key to modify data, the modified data bit can be selected from right to left by pressing this key and the modified bit has flicker display.
Keyboard function		<b>Right shift key.</b> At any status using   key to modify data, the modified data bit can be selected from left to right by pressing this key and the modified bit has flicker display.
		<b>Local, terminal and communication control function switch key.</b> The keyboard control, external terminal control and communication control functions can be switched with each other through setting [F0.0.11]=##1## (the switch status is not stored and lost after power down).
		<b>Shuttle selection key.</b> Adjust data after addition in clockwise rotation and adjust data after subtraction in counterclockwise rotation. When [F0.0.25]=3, select panel shuttle setting.
		<b>Ok key.</b> Confirm the current status and parameters (the parameters are stored in the internal memory) and enter into next-level function menu.

## 5.2 BASIC FUNCTIONS AND OPERATING METHODS OF PANEL

### 5.2.1 BASIC FUNCTIONS OF PANEL

The operation panel also has the following special functions except such basic functions as forward operation, reverse operation, inching operation, shut down, fault reset, parameter modification and inquiry and operating status parameter monitoring, etc.:

- ◆ Parameter copy and read/backup (parameter upload)

This operation panel allows for copying the internal parameters of the frequency inverter to the operation panel (only the internal parameters opened to users) and storing permanently. Therefore, users can backup their typical setting parameters to the operation panel for emergency. The backup parameters in the operation panel do not influence the operation of the frequency inverter and can be checked and modified separately.

When [F0.0.08] =####1, the keyboard will begin to read the internal parameters of the frequency inverter and the operation panel will display the process of reading parameters in real time. After the completion of parameter backup, the display mode will recover to normal monitoring automatically. During parameter backup, the operation can be stopped at any time by pressing  key and the display will switch to normal monitoring mode. If alarm information is occurred, please refer to Chapter 8.

- ◆ Parameter copy/write in (parameter download)

This operation panel allows for copying the backup parameters to the internal memory of the frequency inverter (only the internal parameters opened to users) and users can write in their typical setting parameters backed up in the operation panel into the frequency inverter at one time without separate modification.

When the frequency inverter set F0.0.08 as ## 1 2 or ## 1 3 in stopped mode, the keyboard will begin to copy the backup parameters to frequency inverter and the operation panel will display the process in real



time. After the completion of copying, the display mode will recover to normal monitoring automatically.

During parameter copying, the operation can be stopped at any time to abandon the copied parameters by pressing  key and the display mode will switch to normal monitoring mode. If alarm information is occurred, please refer to Chapter 8.

#### ◆ Check and modification of internal parameters



In normal monitoring mode, the internal parameters of the frequency inverter can be checked and modified as per general methods by pressing  key.

#### ◆ Check and modification of panel backup parameters

In normal monitoring mode, the backup parameters in the operation panel can be checked and modified by pressing  and  key simultaneously (double key compound use) and the high-order code "F" will display flickeringly when function code is displayed. The modification methods of backup parameters are the same as that of internal parameters.

#### ◆ Locking and unlocking of panel







1. Locking: part of or all the keying functions of the panel can be locked through setting the application parameter F0.0.11. If the parameter is set as panel locking mode, the panel will be locked immediately after the frequency inverter is energized.

2. Unlocking: the panel will be unlocked for 5 minutes temporarily by pressing  and maintaining and pressing  twice in order within 5 seconds and it will automatically recover to locking if there's no keying within 5 minutes.



- To unlock the panel thoroughly, the panel locking parameter [F0.0.11] should be modified into "unlocked" status during the temporary unlock of the panel.

#### ◆ Key function

 Key function is limited by the application parameter F.0.0.11. In function enabling and "normal monitoring mode", press  key to switch the operation command channel in order "operation panel" → "local terminal" → "communication interface" → "operation panel".  Indicator displays the selected command channel which will be valid by pressing  within 3 seconds. It will abandon the switch and return to original status by pressing  or without pressing  within 3 seconds.



- When switching command channel, if the original setting is "operation panel" or "local terminal", the "communication interface" will be defaulted as local MODBUS field bus.

The operation command channel switched by this function is not stored permanently. It will recover to original setting after the frequency inverter is power down and restarted. Relevant application parameters of the frequency inverter should be modified to permanently change the command channel.

### 5.2.2 OPERATING METHODS OF PANEL

1) Query for status parameters (e.g.)

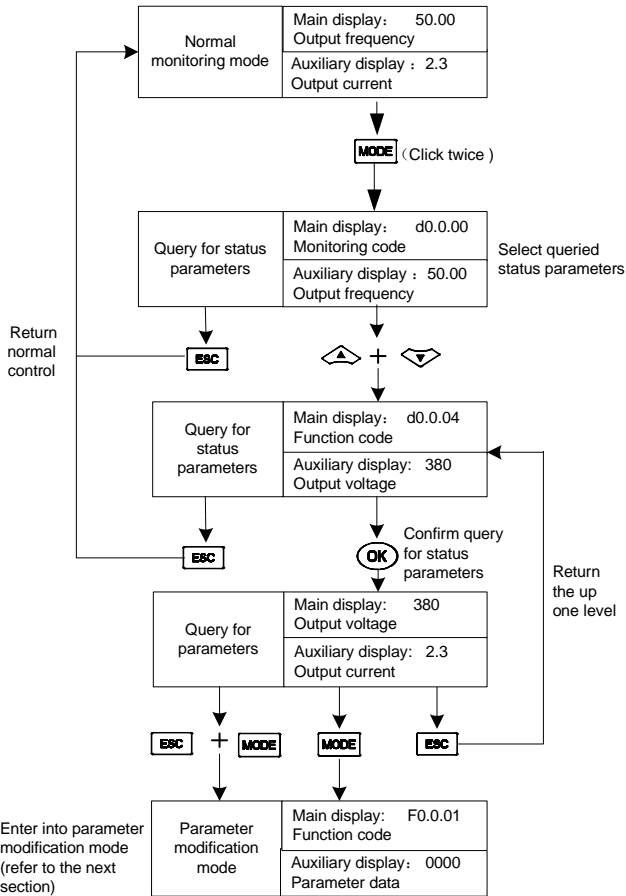

Figure 5-1 Query for status parameters

2) Parameter query and modification (e.g.)

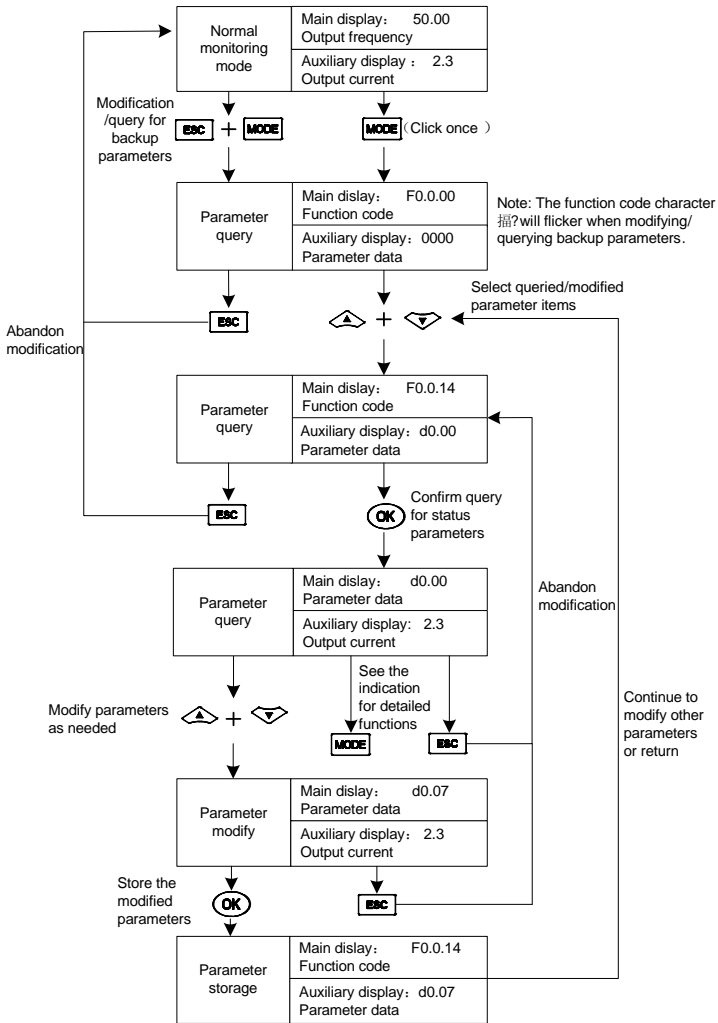

Figure 5-2 Parameter check and modification

Remark: In this status, the auxiliary display column will display the following in turn by pressing **MODE** key repeatedly.

Default auxiliary monitoring parameters (original state) → EROM regional numerical value → parameter values at initial energizing → backup parameters in operation panel, the numerical value will flicker when “EROM regional numerical value”, “parameter values at initial energizing” and “backup parameters in operation panel” are displayed.

## 5.3 SIMPLE RUNNING OF FREQUENCY INVERTER

### 5.3.1 OPERATION PROCESS

Process	Operations	References
Installation and operating environment	Install frequency inverter at the place which complies with the product technical specification. Mainly consider ambient conditions (temperature, humidity, etc.) and heat dissipation of frequency inverter, etc.	Refer to Chapter 1 and 3
Wiring of frequency inverter	Wiring of main circuit input and output terminal; Wiring of grounding wire; Wiring of switching value control terminal, analog terminal, encoder and communication interface	Refer to Chapter 4
Inspection before energizing	<ol style="list-style-type: none"> <li>1. Make sure the voltage of input power supply is correct and the input power supply loop is connected with breaker; The frequency inverter has been correctly and reliably grounded;</li> <li>2. The power cord has been correctly connected with R, S, T power input terminal of the frequency inverter;</li> <li>3. The output terminal of the frequency inverter U, V, W is correctly connected with the motor;</li> <li>4. The encoder is correctly connected with PG card;</li> <li>5. The terminal block is correctly connected and all the external switches are correctly preset;</li> <li>6. The motor is empty-load (the mechanical load is disconnected with motor).</li> </ol>	Refer to Chapter 4
Inspection in energizing	Whether the frequency has abnormal sound, smoking and peculiar smell, etc; And the operation panel displays normally without fault alarm information. If there are abnormalities, please cut off the power supply immediately.	Refer to chapter 3 and 5
Parameter initialization	When the frequency inverter is operated initially, changed internal control panel or controlled motor, it is recommended to conduct the next operation and setting after setting function code F0.0.07 and conducting parameter initialization.	Refer to F0.0.07 parameter function
Correctly input the name plate of the motor	Make sure the name plate parameter of the motor is input correctly and carefully checked by users; Otherwise, serious problems may be occur in operation.	Refer to F2.0.00 ~ F2.0.05 motor 1 and F2.1.26 ~ F2.1.30 motor 2 parameter set
Protection parameter setting for motor and frequency inverter	Correctly set the limit parameter, protection parameter and protection mode of the frequency inverter and the motor, mainly including: the maximum frequency, upper frequency limit, motor overload protection, external fault input, fault relay output and encoder disconnection protection, etc.	Refer to F1.1.39 ~ F1.4.52 parameter set for stable operation, F3.1.12 ~ F3.1.35 parameter set for multifunctional terminal output, F4.3.36~F4.3.50 parameter set for analog input disconnection detection
Automatic learning	The automatic learning for motor parameters should be conducted before selecting vector control mode for the first operation so as to get accurate electric parameters of the controlled motor. If the motor is rotating, please conduct after the motor is completely stopped.	Refer to F2.2.53 parameter set for parameter determination

Process		Operations	References
Set operation control parameters	General parameters	Correctly set direction of rotation, acceleration time, deceleration time, starting frequency, starting mode, acceleration and deceleration mode and stop mode, etc. As per the operating conditions of driving system	Refer to F0.0.17 parameter set, F0.1.20~F0.1.24 parameter set, F0.4.37~F0.4.52 parameter set for starting and stopping, and F1.0.00~F1.0.10 parameter set for acceleration and deceleration characteristics
Set operation control parameters	Vector control	Adjust the parameters of regulator in accordance with load conditions, if necessary, set torque control and limit parameters. For vector control with PG, make sure to correctly set the parameters of encoder.	Refer to F8.0.01 ~ F8.0.15 parameter set for rotating speed setting and feedback
Empty-load commissioning inspection		Empty-load motor; start the frequency inverter with keyboard or control terminals; inspect and confirm the operating conditions of driving system; Motor: stable operation, normal rotation, correct direction, normal acceleration and deceleration process, no abnormal vibration, noise and smell. Frequency inverter: normal display data of operation panel, normal operation of fan, normal sequence of operation of relay, no vibration and noise, etc. If there are abnormalities, please stop and inspect immediately.	Refer to Chapter 3 and 5
Commissioning inspection with load		Connect the load of driving system after normal empty-load commissioning. Start the frequency inverter with keyboard or control terminal and gradually increase load. When the load is increased to 50% and 100%, operate the system for a period of time respectively to inspect whether the operation of the system is normal or not. It shall inspect overall during operation and observe whether there are abnormalities, or it shall stop and inspect immediately.	Refer to Chapter 3 and 5
Basic operation		The frequency inverter can carry out such basic operations as general starting, running, stopping and F/R, etc	Refer to Chapter 3 and 5
Function operation	PLC operation	Frequency conversion operation can be set as single cycle execution or recycle execution. One cycle process includes 15 execution phases whose operating frequency, acceleration and deceleration time, operating time and direction, etc. And can be set separately.	Refer to F6.0.00 ~ F6.0.14 parameter set for multi-frequency setting function, F6.0.15~ F6.0.45 parameter set for simple and programmable multi-section operation function
Function operation	PID operation	Users can set the preset channel and feedback channel for PID process control as well as parameters of PID regulator to realize the control to industrial process.	Refer to F7.0.00 ~ F7.0.26 parameter set for process PID function
	Torque control	Torque control is used under vector control mode and can control the output torque of the motor as per torque command value.	Refer to F8.3.39 ~ F8.3.51 parameter set for torque control function
	Acceleration and deceleration	In order to make acceleration and deceleration process smooth and reduce mechanical impact, users can set S curve acceleration and deceleration function to make the speed of the	Refer to F1.0.00 ~ F1.0.10 function parameter set

Process		Operations	References
		motor vary smoothly in the initial and end phase of acceleration and deceleration.	
	DC braking	Access DC current to rotating motor before starting or in the stopping process to produce braking torque to stop the motor quickly.	Refer to F0.4.44 ~ F0.4.47 parameter set for DC braking function
	Rotating speed tracking	The frequency inverter will automatically track the speed of rotating motor caused by inertia in starting and execute the set starting procedure after smoothly cutting over the current speed of the motor so as to reduce starting impact.	Refer to F0.4.38 parameter functions for starting and stopping mode
	Special terminal control	The switching value has strong control functions and can be used in combination with external control period to constitute various application solutions. Before using the control functions of special terminals, corresponding settings must be conducted in function code	Refer to F3.0.00 ~ F3.0.11 parameter set for multifunctional input terminal function
Inspection during operation		Whether the motor is steadily rotated and the direction of rotation is correct; Whether there's abnormal vibration or noise; Whether the acceleration and deceleration process is stable; whether the output state and panel display of the frequency inverter is correct; Whether the fan is normally operated and there's abnormal vibration or noise; If there are abnormalities, it shall stop and cut off the power supply for inspection immediately.	Refer to Chapter 3 and 5

### 5.3.2 INITIAL SETTING OF FREQUENCY INVERTER

#### 1) Selection of control mode

V560 frequency inverter has three control modes: vector control without PG, vector control with PG and V/F control. The operation control mode is selected by the application parameter F0.0.09.

**Mode 0:** vector control without PG, i.e. vector control without velocity sensor, also called open loop vector control. It is applicable to the place where encoder is not installed, has higher requirement to starting torque and speed control precision and the normal V/F control mode can not satisfied.

**Mode 1:** vector control with PG, i.e. vector control with velocity sensor, also called closed loop vector control. It is applicable to the place where faster response of torque and higher control precision is required.

**Mode 2:** V/F control mode. Except normal V/F control application, it can also be applied to the place where the frequency inverter drives more than one motor.

The control modes of frequency inverter vary from the type and control requirements of motor and set by parameter F0.0.09=####. For instance, the field where three-phase asynchronous motor is used can be selected through setting F0.0.09=###0 and the field where the control precision is highly required with velocity sensor can be set F0.0.09=##1# speed closed loop vector control mode.

**Mode 3:** V/F separate control mode. It is applicable to the separate control of torque motor. Under this control mode, the output voltage and output frequency of the frequency inverter are not related and set by the user itself.



#### 2) Selection of frequency input channel (F0.1.16 and F0.2.25, F0.2.26, F0.2.29, F0.2.32)

V560 frequency inverter has two frequency channels to select parameters with 29 frequency setting modes for each of the channel (refer to parameter F0.2.25, F0.2.26). The two channels can both work independently and set in combination (refer to F0.1.16 parameter). For instance, if F0.1.16 is set as frequency setting channel 1 which is valid separately and F0.2.25 is set as 2 valid panel digital setting (maintaining after stopping and storing after power down), the frequency setting of the frequency inverter will be determined by F0.2.29.



### 3) Operation command input channel ([F0.1.15], [F0.3.33], [F0.3.34])

V560 frequency inverter has 2 control command channels to select parameters with 3 control command forms for each of the channel (refer to F0.3.33, F0.3.34). The two control commands can be selected through external terminal (refer to input function selection table for multifunctional terminal). For instance, when this parameter is set as [F0.1.15]=0 (control command 1 is valid) and F0.3.33 is set as 0 operation panel

command is valid, the start-stop control of the frequency inverter will be completed by  and  key on the operation panel.

## 5.3.3 SIMPLE OPERATION





- It is absolutely forbidden to connect the power cord to the output U, V, W of the frequency inverter.

### 5.3.3.1 SVC (NON-INDUCTIVE VECTOR) OPERATION

Take 7.5KW frequency inverter which drives 7.5KW three-phase AC asynchronous motor as the example to indicate the operation process. The name plate parameters of the motor are:

Rated power: 7.5KW;	Rated voltage: 380V;
Rated current: 15.4A;	Rated frequency: 50.00Hz;
Rated speed: 1440rpm;	Pulse of encoder: 1000PPR

Use operation panel to conduct digital frequency setting and start-stop control.

- Connect as per Figure 5-3;
- Power on after making sure the wiring is correct;
- Set parameters as follows:
  - [F0.0.09]=0000 (non-inductive vector control)
  - [F0.0.00]=0001 (apply macro parameters, set as panel operation digital setting for shortcut)
  - [F2.0.00]=7.5 (rated power of motor)
  - [F2.0.01]=380 (rated voltage of motor)
  - [F2.0.02]=15.4 (rated current of motor)
  - [F2.0.03]=50.00 (rated frequency of motor)
  - [F2.0.04]=1440 (rated speed of motor)
- Press  key to start frequency inverter. If the name plate parameters (F2.0.00 ~ F2.0.04) of the motor are modified in ③, the primary static parameter identification will be started automatically, the frequency inverter will output 0 frequency and the auxiliary display column will display the current output current (not limited by F0.0.13 at this time). When the display current is stable as 0.0, the automatic learning is finished and operation is started;
- Press  key to increase set frequency, where the output frequency of the frequency inverter will be increased and the speed of motor will accelerate;
- Observe the operation of motor, if there are abnormalities, stop it immediately and power off and re-operate it after finding out the causes;
- Press  key to reduce set frequency;

- Press  key to stop operation and cut off the power supply.

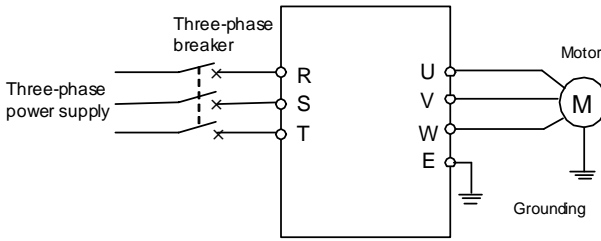

Figure 5-3 Wiring for the operation of SVC mode

### 5.3.3.2 VC (INDUCTIVE VECTOR) OPERATION

The following parameters also need to be set except the above set parameters required by SVC operation. The wiring diagram is as shown in Figure 5-4.

[F0.0.09]=0010 (inductive vector control)

[F8.0.04]=0 (speed feedback channel)

[F8.0.05]=1000 (pulse of encoder per revolution)

[F8.0.06] if F/R periodic vibration is occurred in starting, this parameter shall be set as 1 (or exchange the wiring of A, B pulse) other operations are the same as that of SVC operation.



➤ If the motor is completely empty-load, slight oscillation may occur sometimes in the operation under high carrier frequency. At this time, please reduce the setting value of the carrier frequency. (Parameter [F1.1.13]).

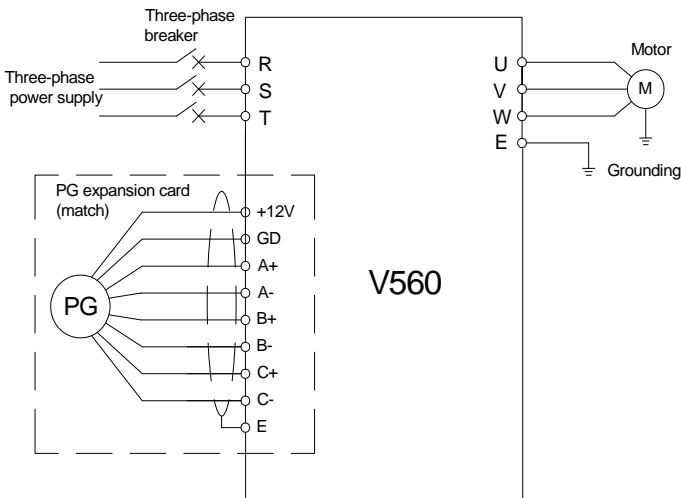

Figure 5-4 Wiring for the operation of VC mode

## 6. FUNCTIONAL PARAMETER TABLE

### 6.1 EXPLANATIONS

1) The symbols in the Table are explained as below:

- ◆ "×" indicates that the set value of the parameter cannot be changed when the inverter is running.
- ◆ "☆" indicates the parameter is relevant with the model of the inverter.
- ◆ "R" indicates the parameter is just for reading and cannot be changed;
- ◆ "R/I" indicates the parameter is just for reading and cannot be changed, but can be cleared by initialization.
- ◆ "—" indicates the parameter is relevant with the type or status of connected accessories.

2) Variables: (H) - hexadecimal number; only bitwise data change is permitted (carry bit is not allowed), and the upper and lower limit for bitwise change.

### 6.2 FUNCTION TABLE

#### 6.2.1 SYSTEM MANAGEMENT PARAMETER

Function Code	Name	Setting Range and Description	Minimum Unit	Factory Default	Change Limit
F0.0.00	Macro parameter	<p>___ X: <b>Application macro (0-F)</b></p> <p>0: Void (customized setting)</p> <p>1: Setting of panel operation digit (factory default)</p> <p>2: Setting of panel operation shuttle</p> <p>3: 2 wire control 1(AT1 setting)</p> <p>4: 2 wire control 2(AT1 setting)</p> <p>5: 3 wire control 1(AT1 setting)</p> <p>6: Tool device spindle drive (AT1 setting)</p> <p>___ X_: <b>Reserved</b></p> <p>__ X__: <b>Configuration macro (reserved)</b></p> <p>X ___: <b>System macro (0-F)</b></p> <p>0: Standard operation</p> <p>1: Variable torque load (e.g. load of fans and pumps)</p> <p>2: Reserved</p>	1	0000	×
F0.0.01	Parameter display and modification (H)	<p>___ X: <b>Parameter display mode</b></p> <p>0: Display all parameters</p> <p>1: Display effective configuration parameters</p> <p>2: Display parameters different from factory default</p> <p>3: Display modified and stored parameters after power-on this time</p> <p>4: Display modified and un-stored parameters after power-on this time</p> <p>___ X_: <b>Parameter modification mode</b></p> <p>0: Effective and permanently stored after modification</p> <p>1: Effective after modification but not stored, and getting lost after power-off</p>	1	0001	

Function Code	Name	Setting Range and Description	Minimum Unit	Factory Default	Change Limit
		<p><b>__X__ : Reserved</b></p> <p><b>X ___ : Parameter batch recovery and batch storage</b></p> <p>2: Abandon modifying all un-saved parameters (restoring to original value)</p> <p>5: Batch storing all modified and un-saved parameters</p> <p>9: Resume all parameters to initial values at the last power-on</p>			
F0.0.02	Modification key for system macro and configuration macro parameters	0~65535(1580)	1	0	×
F0.0.03	Reserve				
F0.0.04	LCD display setting(H)	<p><b>___X: Contrast 0~7</b></p> <p><b>__X_ : Normal display mode</b></p> <p>0: Steady mode</p> <p>1: Single parameter display</p> <p>2: Dual parameter display</p> <p>3: Three parameter display</p>	1	0023	-
F0.0.05	Parameter locking(H)	<p><b>__X : Parameter modification permission</b></p> <p>0: All parameters are permitted to be modified</p> <p>1: Except for this parameter, frequency digital setting, PID digital setting, revolution digital setting, torque digital setting, locking password parameter (F0.0.06), other parameters are forbidden to be modified.</p> <p>2: All parameters are forbidden to be modified except for this parameter and the locking password.</p> <p><b>__X_ : Coded lock</b></p> <p>0: Void</p> <p>1: Effective – once the password is set, this parameter cannot be modified unless correct password is entered.</p>	1	0000	
F0.0.06	Parameter locking password	0~65535	1	0	
F0.0.07	Parameter initialization	<p>0: No action</p> <p>1: Factory Reset parameter groups F0&gt;F9</p> <p>2: Factory Reset parameter groups F0&gt;FA</p> <p>3: Factory Reset parameter groups F0&gt;FB</p> <p>4: Factory Reset parameter groups F0&gt;FC</p> <p>5: Factory Reset parameter groups F0&gt;FD</p> <p>6: Factory Reset parameter groups F0&gt;FE</p> <p>7: Factory Reset parameter groups F0&gt;FF</p> <p>8: Clear away fault records</p>	1	0	×
F0.0.08	Parameter copying(H)	<p><b>___X: Upload and download</b></p> <p>0: No action</p> <p>1: Parameter upload</p> <p>2: Parameter download</p> <p>3: Parameter download (except for motor parameter/F2 Group)</p>	1	0000	×

Function Code	Name	Setting Range and Description	Minimum Unit	Factory Default	Change Limit
		<b>__ X _: Local download permitted</b> 0: Parameter download forbidden 1: Parameter download permitted			
F0.0.09	Motor type and control mode selection (H)	<b>LED ___ X: Motor 1 type selection</b> 0: Induction asynchronous motor 1: Spindle asynchronous servo motor <b>LED __ X _: Motor 1 control mode</b> 0: SVC mode/open-loop vector control 1: VC mode/closed-loop vector control 2: V/F control 3: V/F separate control <b>LED X ___: Motor 2 selection type</b> 0: Induction asynchronous motor 1: Spindle asynchronous servo motor <b>LED X ___: Motor 2 control mode</b> 0: SVC mode/open-loop vector control 1: VC mode/closed-loop vector control 2: V/F control 3: V/F separate control	1	0000	×
F0.0.10	Motor selection	0: Motor 1 1: Motor 2 2: Selection of multifunctional input terminal (Function No.41)	1	0	×
F0.0.11	Selection of panel key functions (H)	<b>___ X: Keypad locking</b> 0: No locking 1: All keys are locked except for UP/DW (Shuttle), Stop and RUN. 2: All keys are locked except for STOP and RUN 3: All keys are locked except for STOP 4: Lock all keys <b>__ X _: STOP button function</b> 0: Non-panel control mode void 1: Press STOP key in any control mode to stop the device slowly 2: Press STOP key in any control mode to stop the device freely <b>_ X _: PANEL/REMOTE button function</b> 0: Void 1: Stop effective 2: Continuously effective <b>X ___: Reserved</b>	1	0000	×
F0.0.12	Principal monitoring parameter (H)	d0.0~d0.55 / d1.0~d1.55	1	d0.00	
F0.0.13	Auxiliary monitoring parameter 1 (H)	d0.0~d0.55 / d1.0~d1.55	1	d0.02	
F0.0.14	Auxiliary monitoring parameter 2 (H)	d0.0~d0.55 / d1.0~d1.55	1	d0.04	

## 6.2.2 SELECTION OF RUNNING COMMANDS

Function Code	Name	Setting Range and Description	Minimum Unit	Factory Default	Change Limit
F0.1.15	Selection of running command source	0: Control command 1 effective 1: Control command 2 effective 2: Selection of multifunctional input terminal (Function No. 11)	1	0	
F0.1.16	Selection of frequency set value (when one source of combination set is bipolar set, the final direction of the combination results shall be the direction of setting source1)	0: Frequency setting source 1 is independently effective 1: Frequency setting source 2 is independently effective 2: Selection of multifunctional input terminal (Function No.12) 3: Bound with the start-stop command channel 4: Channel 1 + Channel 2 5: Channel 1 amplified by Channel 2 6: Channel 1 - Channel 2 7: Channel 1 reduced by Channel 2 8: Channel 1 reduced by Channel 2 9: Highest value Channel 1 OR Channel 2 10: Lowest value Channel 1 OR Channel 2 11: $\sqrt{(\text{Channel 1}) + \sqrt{(\text{Channel 2})}}$ 12: $\sqrt{(\text{Channel 1} + \text{Channel 2})}$ 13: $(\text{Channel1} \times \text{Scaling1}) + (\text{Channel 2} \times \text{Scaling 2})$ 14: $(\text{Channel1} \times \text{Scaling1}) + (\text{Channel 2} \times \text{Scaling 2})$	1	0	
F0.1.17	Running direction(H)	<b>__ _ X: Direction switch</b> 0: Void 1: Negate <b>__ _ X_: Direction locking</b> 0: Void (determined by the direction command) 1: FWD locking 2: REV locking	1	0000	
F0.1.18	Action coefficient of frequency setting channel1	0.01~100.00	0.01	1.00	
F0.1.19	Action coefficient of frequency setting channel2	0.01~100.00	0.01	1.00	
F0.1.20	Maximum output frequency	10.00~320.00Hz/100.0~2000.0Hz	0.01	60.00	
F0.1.21	Upper limiting frequency	[F0.1.22]~Min. (300.00Hz,[F0.1.20])	0.01	50.00	
F0.1.22	Lower limiting frequency	0.0Hz~[F0.1.21]	0.01	0.0	
F0.1.23	FWD jog frequency	0.0Hz~[F0.1.21]	0.01	10.00	
F0.1.24	REV jog frequency	0.0Hz~[F0.1.21]	0.01	10.00	

### 6.2.3 FREQUENCY SETTING

Function Code	Name	Setting Range and Description	Minimum Unit	Factory Default	Change Limit
F0.2.25	Frequency setting channel 1	0: Panel digital setting (maintained after stop ) 1: Panel digital setting (zero clearing after stop) 2 :Panel digital setting (maintained after stop and saved after power-off) 3: Setting of panel shuttle potentiometer 4: Remote UP/DW 1 (keep value at power off) 5: Remote UP/DW 2 (go to zero when stopped) 6: Remote UP/DW 3 (keep value at power off) 7: Remote UP/DW Bipolar Setting 1 (keep bipolar when stopped) 8: Remote UP/DW Bipolar Setting 2 (keep at power off) 9: Analog input AI1 10: Analog input AI2 11: Analog input AI3 12: Given by the analog input AI1 bipolarity 13: Given by the analog input AI3 bipolarity 14: Pulse input Fin 15: Given by the pulse input bipolarity		2	
F0.2.26	Frequency setting channel 2	16: MODBUS fieldbus set value 1 (relative set value) 17: MODBUS fieldbus set value 2 (absolute set value) 18: AI1+AI2 19: AI2+AI3 20: AI2+pulse input Fin 21: AI1*AI2/rail-to-rail input (10V) 22: AI1/AI2 23: Process PID output 24: Compensation PID output 25: Disturbance running frequency 26: Automatic multi-sage running frequency 27: Terminal selection multi-stage frequency 28: Virtual analog input SAI1 29: Virtual mode input SAI2  In the case of V/F separate control, F0.2.25 changes to frequency giving channel, and F0.2.26 changes to voltage giving channel.	1	0	
F0.2.27	Minimum value of frequency setting source 1	0.0~[F0.2.28]	0.01	0.0	
F0.2.28	Maximum value of frequency setting source 1	[F0.2.27]~[F0.1.20]	0.01	50.0	
F0.2.29	Panel digital set value of frequency setting source 1	0.0~[F0.1.28]	0.01	0.0	

Function Code	Name	Setting Range and Description	Minimum Unit	Factory Default	Change Limit
F0.2.30	Minimum value of frequency setting source 2	0.0~[F0.2.31]	0.01	0.0	
F0.2.31	Maximum value of frequency setting source 2	[F0.2.30]~[F0.2.20]	0.01	50.0	
F0.2.32	Panel digital set value of frequency setting source 2	0.0~[F0.2.31]	0.01	0.0	

### 6.2.4 CONTROL COMMAND SOURCE

Function Code	Name	Setting Range and Description	Minimum Unit	Factory Default	Change Limit
F0.3.33	Control command 1	0: Operating panel	1	0	
F0.3.34	Control command 2	1: External control terminal 2: MODBUS fieldbus /standard expansion card configuration	1	0	
F0.3.35	External control terminal action mode (H)	<b>___X: Control command</b> 0: 2 wire mode 1 1: 2 wire mode 2 2: 3 wire mode 1 3: 3 wire mode 2 <b>__X_: Command power-on first starting</b> 0: Running signal level starting 1: Running signal rising edge starting (2 wire mode 1 and 2) <b>_X_: Reserved</b> <b>X___: Reserved</b>	1	0000	×
F0.3.36	Reserve				

### 6.2.5 START AND STOP

Function Code	Name	Setting Range and Description	Minimum Unit	Factory Default	Change Limit
F0.4.37	Start/Running permission(H)	<b>LED ___X: Start permission</b> 0: Function closed 1: Permitted when the multifunctional terminal is effective (Function No. 42) 2: Command word from standard fieldbus (standard expansion card) <b>LED __X_: Reserved</b> <b>LED _X_: Running permission</b> 0: Function closed 1: Permitted when the multifunctional terminal is effective (Function No. 43) 2: Command word from standard fieldbus (standard expansion card) <b>LED X___: The action mode when the running permission signal is void</b> 0: Free stop 1: Deceleration stop	1	0000	×



Function Code	Name	Setting Range and Description	Minimum Unit	Factory Default	Change Limit
F0.4.38	Start/Stop Mode(H)	<p>___ X: <b>Start mode</b>  0: Normal start  1: Revolution tracking start</p> <p>___ X : <b>Reserved</b>  _ X _ : <b>Stop mode</b>  0: Deceleration stop  1: Free stop</p>	1	0000	×
F0.4.39	Start frequency	0.0~50.00Hz	0.01	0.50	
F0.4.40	Start frequency holding time	0.00~10.00Sec.	0.01	0.0	
F0.4.41	Start pre-excitation current	0.0~100.0(%)	0.1	35.0	
F0.4.42	Start pre-excitation time	0.00~10.00Sec.	0.01	0.10	
F0.4.43	Start delay	0.00~10.00Sec.	0.01	0.0	
F0.4.44	DC band-type brake control	<p>___ X: <b>DC band-type brake function</b>  0: Closed  1: Open</p> <p>___ X _ : <b>Reserved</b></p>	1	0	
F0.4.45	DC band type brake/brake initial frequency / speed	0.0~[F0.1.21]	0.01	2.00	
F0.4.46	DC brake action time	0.0~10.00Sec.	0.01	0.0	
F0.4.47	DC band-type brake/brake injection current	0.0~100.0(%)	0.1	50.0	
F0.4.48	Restart after power-off	0: Forbidden            1: Effective	1	0	
F0.4.49	Standby time for restart after power-off/free stop	0.1~10.0Sec.	0.1	0.5	
F0.4.50	FWD and REV transition dead time	0.00~5.00Sec.	0.01	0.00	
F0.4.51	FWD and REV switch mode	0: Switch at zero point 1: Start frequency switch	1	0	
F0.4.52	Zero speed (frequency) detection level	0.00~100.00Hz	0.01	0.10 Hz	
F0.4.53	Zero speed delay time	0.00~10.00Sec.	0.01	0.05	
F0.4.54	Emergency stop mode (EMS)	<p>0: The inverter will stop in deceleration mode according to the emergency stop and deceleration time.</p> <p>1: The inverter will immediately lock output and the motor will stop in free sliding mode.</p>	1	0	

## 6.2.6 ACCELERATION AND DECELERATION CHARACTERISTICS PARAMETERS

Function Code	Name	Setting Range and Description	Minimum Unit	Factory Default	Change Limit
F1.0.00	Acceleration and deceleration characteristics parameters	<b>___X: Accel decele mode</b> 0: Linear acceleration and deceleration 1: S curve acceleration and deceleration <b>__X_: Unit of acceleration and deceleration time</b> 0: Sec. (Second) 1: Min. (Minute)	1	0000	×
F1.0.01	% of S curve at the bottom	5.0~100.0-[F1.0.02]	0.1	15.0	
F1.0.02	% of S curve at mid section	20.0~100.0-[F1.0.01]	0.1	70.0	
F1.0.03	Acceleration time1	0.01~ 600.00 (Sec./Min.)	0.01	☆	
F1.0.04	Deceleration time1	0.01~ 600.00 (Sec./Min.)	0.01	☆	
F1.0.05	Acceleration time2	0.01~ 600.00 (Sec./Min.)	0.01	☆	
F1.0.06	Deceleration time2	0.01~ 600.00 (Sec./Min.)	0.01	☆	
F1.0.07	Acceleration time3	0.01~ 600.00 (Sec./Min.)	0.01	☆	
F1.0.08	Deceleration time3	0.01~ 600.00 (Sec./Min.)	0.01	☆	
F1.0.09	Acceleration 4/jog acceleration time	0.01~ 600.00 (Sec./Min.)	0.01	☆	
F1.0.10	Deceleration 4/jog deceleration time	0.01~ 600.00 (Sec./Min.)	0.01	☆	
F1.0.11	EMS emergency stop and deceleration time	0.01~ 600.00 (Sec./Min.)	0.01	☆	
F1.0.12	Reserve				

## 6.2.7 CARRIER FREQUENCY

Function Code	Name	Setting Range and Description	Minimum Unit	Factory Default	Change Limit
F1.1.13	Carrier frequency	Three-phase voltage vector composition (FF.4.43=##0#) mode: 1.5~12.0KHz Two-phase voltage vector composition (FF.4.43 =##1#) mode: 1.5~15.0KHz		☆	
F1.1.14	Carrier characteristics	<b>___X: Load linkage adjustment</b> 0: Void            1: Effective <b>__X_: Temperature linkage adjustment</b> 0: Void            1: Effective <b>_X__: Reference frequency linkage adjustment</b> 0: Void            1: Effective <b>X___: Modulation mode</b> 0: Asynchronous modulation 1: Synchronous modulation 2~5: Sound smooth	1	0111	

## 6.2.8 V/F PARAMETERS AND OVERLOAD PROTECTION (MOTOR 1)

Function Code	Name	Setting Range and Description	Minimum Unit	Factory Default	Change Limit
F1.2.15	Reference frequency of motor 1	5.00~300.00Hz/ 50.0~2000.0Hz	0.01	50.00	×
F1.2.16	Reference voltage of motor1	50~500V	1	380/220	
F1.2.17	V/F curve selection for motor 1	0: Customized curve 1: 1.2 times squares curve 2: 1.5 times squares curve 3: Second square curve	1	0	×
F1.2.18	Torque increasing voltage for motor1	0.0~20.0%	0.1	☆	
F1.2.19	Frequency point 1 of motor 1 V/F curve	0.0~[F0.1.21]	0.01	0.0	×
F1.2.20	Voltage point 1 of Motor 1 V/F curve	0~500V	0.1	0.0	
F1.2.21	Frequency point2 of motor 1 V/F curve	0.0~[F0.1.21]	0.01	0.0	×
F1.2.22	Voltage point 2 of Motor 1 V/F curve	0~500V	0.1	0.0	
F1.2.23	Frequency point3 of motor 1 V/F curve	0.0~[F0.1.21]	0.01	0.0	×
F1.2.24	Voltage point 3 of Motor 1 V/F curve	0~500V	0.1	0.0	
F1.2.25	Slip frequency compensation for motor 1	0~150(%)	1	0	

## 6.2.9 V/F PARAMETERS AND OVERLOAD PROTECTION (MOTOR 2)

Function Code	Name	Setting Range and Description	Minimum Unit	Factory Default	Change Limit
F1.3.27	Reference frequency of motor 2	5.00~300.00Hz/ 50.0~2000.0Hz	0.01	50.00	×
F1.3.28	Reference voltage of motor 2	50~500V	1	380/220	
F1.3.29	V/F curve selection for motor 2	0: Customized curve 1: 1.2 times squares curve 2: 1.5 times squares curve 3: Second square curve	1	0	×
F1.3.30	Torque increasing voltage for motor2	0.0~20.0%	0.1	☆	
F1.3.31	Frequency point 1 of motor 2 V/F curve	0.0~[F0.1.21]	0.01	0.0	×
F1.3.32	Voltage point 1 of Motor 2 V/F curve	0~500V	0.1	0.0	
F1.3.33	Frequency point 2 of motor 2 V/F curve	0.0~[F0.1.21]	0.01	0.0	×
F1.3.34	Voltage point 2 of Motor 2 V/F curve	0~500	0.1	0.0	
F1.3.35	Frequency point 3 of motor 2 V/F curve	0.0~[F0.1.21]	0.01	0.0	×
F1.3.36	Voltage point 3 of Motor 2 V/F curve	0~500V	0.1	0.0	
F1.3.37	Slip frequency compensation for motor 2	0~150(%)	1	0	

## 6.2.10 STEADY RUNNING

Function Code	Name	Setting Range and Description	Minimum Unit	Factory Default	Change Limit
F1.4.39	Acceleration/deceleration current limiting level	120~180(%)	1	160	
F1.4.40	Strong start current limiting level	120~200(%)	1	160	
F1.4.41	Strong start current holding time	0.0~5.00Sec.	0.01	0.0	
F1.4.42	Function selection for adjustors	<p>___X: <b>Overvoltage suppression adjustor</b>  0: Closed  1: Effective (Frequency increasing suppression)  2: Terminal inputs</p> <p>__X_: <b>Under voltage suppression adjustor</b>  0: Closed      1: Effective</p> <p>_X__: <b>Frequency modulation and current limiting adjustor</b>  0: Closed      1: Effective</p> <p>X___: <b>Failure Auto Recovery Mode</b>  0: Speed tracking start  1: Normal Start</p>	1	0111	
F1.4.43	Action level of the overvoltage adjustor	660~800V	1	740	
F1.4.44	Overvoltage adjusting gain	0.10~10.00	0.01	1.00	
F1.4.45	Action level of the under voltage adjustor	[FF.2.35]~480V	1	400V	
F1.4.46	Under voltage adjusting gain	0.10~10.00	0.01	1.00	
F1.4.47	Action level of the frequency decreasing and current limiting adjustor	20~200(%)	1	190	
F1.4.48	Adjusting gain of the frequency decreasing and current limiting adjustor	0.10~10.00	0.01	1.00	
F1.4.49	Recovery times of fault self resetting	0~5 (the self-recovery function is deactivated when it is set to 0)	1	0	
F1.4.50	The recovery waiting time of fault self resetting	0.2~100.0Sec.	0.1	1.0	
F1.4.51	Time period for self resetting timing	900~36000Sec.	1	3600	

Function Code	Name	Setting Range and Description	Minimum Unit	Factory Default	Change Limit
F1.4.52	Selection of self resetting fault	<p>___ X: <b>Over current</b>  0: Self resetting forbidden  1: Self resetting permitted</p> <p>___ X: <b>Overvoltage</b>  0: Self resetting forbidden  1: Self resetting permitted</p> <p>___ X: <b>Output grounding</b>  0: Self resetting forbidden  1: Self resetting permitted</p> <p>X ___: <b>Running under voltage</b>  0: Self resetting forbidden  1: Self resetting permitted</p>	1	0000	
F1.4.53	Display coefficient	0.001~60.000	0.001	1.000	

### 6.2.11 VECTOR RUNNING PARAMETERS (MOTOR 1)

Function Code	Name	Setting Range and Description	Minimum Unit	Factory Default	Change Limit
F2.0.00	Rated power	0.1~400.0KW	0.1KW	☆	×
F2.0.01	Rated voltage	30~480V	1V	380/220	×
F2.0.02	Rated current	0.01~650.00A	0.01A	☆	×
F2.0.03	Rated frequency	max{5.00,[F2.0.04]/60}~300.00Hz	0.01Hz	50.00	×
F2.0.04	Rated revolution	10~min.{30000,60*[F2.0.03]}rpm	1rpm	☆	×
F2.0.05	Idling current	0.15*[F2.0.02]~0.8*[F2.0.02]	0.01A	☆	×
F2.0.06	Stator resistance	0.01~65000mΩ	☆	☆	×
F2.0.07	Stator inductance	0.001~6500.0mH	☆	☆	×
F2.0.08	Total leakage inductance	0.001~6500.0mH	☆	☆	×
F2.0.09	Rotator time constant	5.0~6500.0ms	0.1ms	☆	×
F2.0.10	Slip compensation coefficient	0.25~2.00	0.01	1.00	
F2.0.11~F2.0.23	Retention parameter				×
F2.0.24	Z pulse initial angle	0.0~359.9	0.1	0.0	×
F2.0.25	Motor overload protection coefficient	50.0~131.0(%) (131—closed)	0.1	110.0	

### 6.2.12 VECTOR RUNNING PARAMETERS (MOTOR 2)

Function Code	Name	Setting Range and Description	Minimum Unit	Factory Default	Change Limit
F2.1.26	Rated power	0.1~1000.0KW	0.1 KW	☆	×
F2.1.27	Rated voltage	30~480V	1V	380/220	×
F2.1.28	Rated current	0.01~650.00A	0.01A	☆	×
F2.1.29	Rated frequency	max{5.00,[F2.1.30]/60}~300.00Hz	0.01Hz	50.00	×
F2.1.30	Rated revolution	10~min.{30000,60*[F2.1.29]}rpm	1rpm	☆	×
F2.1.31	Idling current	0.15*[F2.1.28]~0.8*[F2.1.28]	0.01A	☆	×

Function Code	Name	Setting Range and Description	Minimum Unit	Factory Default	Change Limit
F2.1.32	Stator resistance	0.01~65000mΩ	☆	☆	×
F2.1.33	Stator inductance	0.001~6500.0mH	☆	☆	×
F2.1.34	Total leakage inductance	0.001~6500.0mH	☆	☆	×
F2.1.35	Rotator time constant	5.0~6500.0ms	0.1ms	☆	×
F2.1.36	Slip compensation coefficient	0.25~2.00	0.01	1.00	
F2.1.37 ~F2.1.49	Retention parameter				×
F2.1.50	Z pulse initial angle	0.0~359.9	0.1	0.0	×
F2.1.51	Motor overload protection coefficient	50.0~131.0(%) (131—closed)	0.1	110.0	



- The stator resistance, stator inductance and the Minimum Unit of total leakage inductance of asynchronous motors is relevant with different models.

### 6.2.13 PARAMETER MEASUREMENT AND PRE-EXCITATION

Function Code	Name	Setting Range and Description	Minimum Unit	Factory Default	Change Limit
F2.2.52	Start excitation time in vector mode	0.02~2.50Sec.	0.01	☆	
F2.2.53	Motor parameter measurement	0: Closed 1: Static identification 2: Static + operating parameter identification 3: Static + operating parameter identification + revolution ratio identification	1	0	×

### 6.2.14 MULTIFUNCTIONAL INPUT TERMINAL

Function Code	Name	Setting Range and Description	Minimum Unit	Factory Default	Change Limit
F3.0.00	Multifunctional input terminal DI1	0~96	1	0	×
F3.0.01	Multifunctional input terminal DI2	0~96	1	0	×
F3.0.02	Multifunctional input terminal DI3	0~96	1	7	×
F3.0.03	Multifunctional input terminal DI4	0~96	1	8	×
F3.0.04	Multifunctional input terminal DI5	0~96	1	13	×
F3.0.05	Multifunctional input terminal DI6	0~96	1	0	×

Function Code	Name	Setting Range and Description	Minimum Unit	Factory Default	Change Limit
F3.0.06	Multifunctional input terminal DI7/ standard expansion card	0~96	1	0	×
F3.0.07	Multifunctional input terminal DI8 / standard expansion card	0~96	1	0	×
F3.0.08	Multifunctional input terminal DI9/Fin/ standard expansion card	0~98	1	97	×
F3.0.09	Multifunctional terminal filtering time (DI1~DI5)	1~50ms	1	5ms	
F3.0.10	Multifunctional terminal filtering time (DI6~DI9) /standard expansion card	1~50ms	1	5ms	
F3.0.11	Input terminal effective level (H)	<p>___X: DI1~DI4 terminal 0~F: 4-bit binary, bit=0 power-on effective, 1 disconnection effective</p> <p>__X_: DI5~DI8 terminal The same as above</p> <p>_X__: DI9 terminal The same as above</p> <p>X___: Reserved</p>	1	0000	×

## 6.2.15 MULTIFUNCTIONAL OUTPUT TERMINAL

Function Code	Name	Setting Range and Description	Minimum Unit	Factory Default	Change Limit
F3.1.12	Multifunctional output terminal DO1	0~71	1	1	
F3.1.13	Multifunctional output terminal DO2	0~71	1	2	
F3.1.14	Multifunctional output terminal DO3/ Fout/standard expansion card	0~71	1	63	
F3.1.15	DO1 terminal effective signal output delay time	0.0~10.00Sec.	0.01	0.0	
F3.1.16	DO1 terminal void signal output delay time	0.0~10.00Sec.	0.01	0.0	
F3.1.17	DO2 terminal effective signal output delay time	0.0~10.00Sec.	0.01	0.0	
F3.1.18	DO2 terminal void signal output delay time	0.0~10.00Sec.	0.01	0.0	
F3.1.19	DO3 terminal effective signal output delay time	0.0~10.00Sec.	0.01	0.0	
F3.1.20	DO3 terminal void signal output delay time	0.0~10.00Sec.	0.01	0.0	
F3.1.21	Multifunctional relay output (RO1A/B/C)	0~71	1	4	
F3.1.22	Multifunctional relay output (RO2A/B/C)/standard expansion card	0~71	1	5	
F3.1.23	RO1 power-on delay time	0.0~10.00Sec.	0.01	0.0	
F3.1.24	RO1 disconnection delay time	0.0~10.00Sec.	0.01	0.0	

Function Code	Name	Setting Range and Description	Minimum Unit	Factory Default	Change Limit
F3.1.25	RO2 power-on delay time	0.0~10.00Sec.	0.01	0.0	
F3.1.26	RO2 disconnection delay time	0.0~10.00Sec.	0.01	0.0	
F3.1.27	Input variable of monitor 1	0~44 (reverting to the monitor variable comparison table)	1	0	
F3.1.28	Input variables of monitor 2	0~44 (referring to the monitor variable comparison table)	1	1	
F3.1.29	Input variables of monitor 3	0~44 (referring to the monitor variable comparison table)	1	2	
F3.1.30	Lower limiting value of monitor 1 variables (relative to full scale value)	0.0~100.0 (%)	0.1	0.0	
F3.1.31	Upper limiting value of monitor 1 variables (relative to full scale value)	0.0~100.0 (%)	0.1	100.0	
F3.1.32	Lower limiting value of monitor 2 variables (relative to full scale value)	0.0~100.0 (%)	0.1	0.0	
F3.1.33	Upper limiting value of monitor 2 variables (relative to full scale value)	0.0~100.0 (%)	0.1	100.0	
F3.1.34	Lower limiting value of monitor 3 variables (relative to full scale value)	0.0~100.0 (%)	0.1	0.0	
F3.1.35	Upper limiting value of monitor 3 variables (relative to full scale value)	0.0~100.0 (%)	0.1	100.0	

## 6.2.16 PULSE INPUT

(Configured with standard expansion I/O board, and this group of parameters are effective when D19 selects the frequency input function)

Function Code	Name	Setting Range and Description	Minimum Unit	Factory Default	Change Limit
F3.2.36	Minimum pulse input frequency DI9/Fin	0.0~100.00KHz	0.01	0.0	
F3.2.37	Maximum pulse input frequency DI9/Fin	0.01~100.00KHz	0.01	10.0	
F3.2.38	Pulse detection cycle	1ms~20ms	1	10ms	
F3.2.39	Number of single-loop pulse	1~4096	1	1024	
F3.2.40	Mechanical transmission ratio (=pulse shaft revolution: motor shaft revolution)	0.010 ~ 10.000	0.001	1.000	
F3.2.41	Driving wheel diameter (for liner speed calculation)	0.1~2000.0mm	0.1	100.0	
F3.2.42	Maximum accumulative length value	10m~50000m	1m	50000	
F3.2.43	Maximum liner speed	0.01~500.00m/Sec.	0.01	10.00	
F3.2.44	Current accumulative length value	0~50000m	1m	—	R
F3.2.45	Current liner speed	0.0~500.00m/Sec.	0.01	—	R



## 6.2.17 PULSE OUTPUT

(Equipped with standard expansion I/O board, and this group of parameters are effective when DO3 terminal selects the frequency output function)

Function Code	Name	Setting Range and Description	Minimum Unit	Factory Default	Change Limit
F3.3.46	Type of output pulse signal DO3/Fout	0: Frequency signal (0.25~100.00KHz) 1: Frequency signal 2: Pulse width modulation (PWM) signal (reference frequency 0.25~100.00KHz)	1	0	
F3.3.47	Minimum output frequency DO3/Fout	0.25~100.00KHz	0.01	0.25	
F3.3.48	Maximum output frequency DO3/Fout	0.25~100.00KHz (PWM signal reference frequency)	0.01	10.0	
F3.3.49	Pulse output mapping variable	0~44 (Monitor Variable Comparison Table)	1	0	
F3.3.50	DO3/Fout assignment lower limit	0.0~[F3.3.51]	0.1	0.0	
F3.3.51	DO3/Fout assignment upper limit	[F3.3.50]~100.0 (%)	0.1	100.0	

## 6.2.18 ANALOG INPUT

Function Code	Name	Setting Range and Description	Minimum Unit	Factory Default	Change Limit
F4.0.00	AI1 min. value (0~10V)	0.00~[F4.0.01]	0.01	0.0	
F4.0.01	AI1 max. value (0~10V)	[F4.0.00]~10.00V	0.01	10.00	
F4.0.02	AI2 min. value (4~20mA)	0.00~[F4.0.03]	0.01	4.00	
F4.0.03	AI2 max. value (4~20mA)	[F4.0.02]~20.00mA	0.01	20.00	
F4.0.04	AI3 min. value (-10V~10V)/ standard expansion card	-10.00~[F4.0.05]	0.01	0.00	
F4.0.05	AI3 max. value (-10V~10V)/ standard expansion card	[F4.0.04]~10.00V	0.01	10.00	
F4.0.06	AI1 filtering time coefficient	1~1000ms	1	10ms	
F4.0.07	AI2 filtering time coefficient	1~1000ms	1	10ms	
F4.0.08	AI3 filtering time coefficient/ standard expansion card	1~1000ms	1	10ms	

## 6.2.19 ANALOG INPUT CURVE CORRECTION

Function Code	Name	Setting Range and Description	Minimum Unit	Factory Default	Change Limit
F4.1.09	AI1 curve correction point 1	[F4.0.00]~[F4.0.01]	0.01	0.0	
F4.1.10	AI1 curve correction value1	[F4.0.00]~[F4.0.01]	0.01	0.0	
F4.1.11	AI1 curve correction point 2	[F4.0.00]~[F4.0.01]	0.01	10.00	
F4.1.12	AI1 curve correction value 2	[F4.0.00]~[F4.0.01]	0.01	10.00	
F4.1.13	AI2 curve correction point 1	[F4.0.02]~[F4.0.03]	0.01	4.00	

Function Code	Name	Setting Range and Description	Minimum Unit	Factory Default	Change Limit
F4.1.14	AI2 curve correction value 1	[F4.0.02]~[F4.0.03]	0.01	4.00	
F4.1.15	AI2 curve correction point 2	[F4.0.02]~[F4.0.03]	0.01	20.00	
F4.1.16	AI2 curve correction value 2	[F4.0.02]~[F4.0.03]	0.01	20.00	
F4.1.17	AI3 zero hysteresis/ standard expansion card	0.0~2.00	0.01	0.10	
F4.1.18	AI3 curve correction point 1/ standard expansion card	[F4.0.04]~[F4.0.05]	0.01	0.0	
F4.1.19	AI3 curve correction value 1/ standard expansion card	[F4.0.04]~[F4.0.05]	0.01	0.0	
F4.1.20	AI3 curve correction point 2/ standard expansion card	[F4.0.04]~[F4.0.05]	0.01	10.00	
F4.1.21	AI3 curve correction value 2/ standard expansion card	[F4.0.04]~[F4.0.05]	0.01	10.00	

## 6.2.20 ANALOG OUTPUT

Function Code	Name	Setting Range and Description	Minimum Unit	Factory Default	Change Limit
F4.2.22	AO1 mapping variable (subjecting to F5.4.44 exceeding function )	0~44(monitor variable comparison table)	1	0	
F4.2.23	AO2 mapping variable/standard expansion card	0~44 (monitor variable comparison table)	1	2	
F4.2.24	AO1 mini value	0.00~10.00V	0.01	0.0	
F4.2.25	AO1 max value	0.00~10.00V	0.01	10.00	
F4.2.26	AO1 lower limiting value	0.0~[F4.2.27]	0.1	0.0	
F4.2.27	AO1 upper limiting value	[F4.2.26]~100.0 (%)	0.1	100.0	
F4.2.28	AO1 filtering time coefficient	0.01~10.00Sec.	0.01	0.10	
F4.2.29	AO1 fixed output value (at the time of fixed output value)	0.0~20.00mA (0.0~10.00V)	0.01	0.0	
F4.2.30	AO2 min value	0.00~10.00V	0.01	0.0	
F4.2.31	AO2 max value	0.00~10.00V	0.01	10.00	
F4.2.32	AO2 lower limiting value	0.0~[F4.2.33]	0.1	0.0	
F4.2.33	AO2 upper limiting value	[F4.2.32]~100.0 (%)	0.1	100.0	
F4.2.34	AO2 filtering time coefficient	0.01~10.00Sec.	0.01	0.10	
F4.2.35	AO2 fixed output value (at the time of fixed output value)	0.0~20.00mA (0.0~10.00V)	0.01	0.0	

## 6.2.21 ANALOG INPUT POWER FAILURE DETECTION

Function Code	Name	Setting Range and Description	Minimum Unit	Factory Default	Change Limit
F4.3.36	Analog input power failure detection function	<p>___X: <b>AI1 power failure detection</b> 0: Void      1: Effective</p> <p>__X_: <b>AI2 power failure detection</b> 0: Void      1: Effective</p> <p>_X__: <b>AI3 power failure detection</b> 0: Void      1: Effective</p>	1	0000	×
F4.3.37	AI1 power failure detection threshold	0.00~10.00V	0.01	0.25	
F4.3.38	AI1 power failure detection delay time	0.01~50.00Sec.	0.01	2.00	
F4.3.39	AI1 power failure detection response	<p>0: No action (for non-stop alarm)</p> <p>1: Forcely set to the minimum</p> <p>2: Forcely set to the maximum</p> <p>3: Forcely set to the defaults value (F4.3.40)</p> <p>4: Inverter forced trip stop</p>	1	0	×
F4.3.40	AI1 power failure default value	0.00~10.00V	0.01	0.0	
F4.3.41	AI2 power failure detection threshold	0.00~20.00mA	0.01	4.00	
F4.3.42	AI2 power failure detection delay time	0.01~50.00Sec.	0.01	2.00	
F4.3.43	Action selection after AI2 power failure	<p>0: No action(for non-stop alarm)</p> <p>1: Forcely set to the minimum</p> <p>2: Forcely set to the maximum</p> <p>3: Forcely set to the defaults value (F4.3.44)</p> <p>4: Inverter forced trip stop</p>	1	0	×
F4.3.44	AI2 power failure default value	0.00~20.00mA	0.01	4.00	
F4.3.45	AI3 power failure detection upper threshold	-10.00~10.00V	0.01	0.25	
F4.3.46	AI3 power failure detection lower threshold	-10.00~10.00V	0.01	-0.25	
F4.3.47	AI3 power failure detection delay time	0.01~50.00Sec.	0.01	2.00	
F4.3.48	AI3 power failure detection response	<p>0: No action(for non-stop alarm)</p> <p>1: Forcely set to the minimum</p> <p>2: Forcely set to the maximum</p> <p>3: Forcely set to the defaults value (F4.3.49)</p> <p>4: Inverter forced trip stop</p>	1	0	×
F4.3.49	AI3 power failure default value	-10.00~10.00V	0.01	0.0	

### 6.2.22 VIRTUAL ANALOG INPUT

Function Code	Name	Setting Range and Description	Minimum Unit	Factory Default	Change Limit
F4.4.50	Virtual analog input SAI1	0: Void (0 value) 1: SAI_COF1*AI1	1	0	×
F4.4.51	Virtual analog input SAI2	2: SAI_COF1*AI2 3: SAI_COF1*AI3 4: SAI_COF1*AO1 5: SAI_COF1*AO2 6: SAI_COF1*AI1+SAI_COF2*AI2+SAI_CST 7: SAI_COF1*AI1+SAI_COF2*AI3+SAI_CST 8: SAI_COF1*AO1+SAI_COF2*AO2+SAI_CST 9: SAI_COF1*AI1+SAI_COF2*AO1+SAI_CST 10: SAI_COF1*AI2+SAI_COF2*AO2+SAI_CST 11: SAI_COF1*AI1+SAI_COF2*AO1 12: SAI_COF1*AI3+SAI_COF2*AO2 13: SAI1_COF*AI1/AI2+ SAI_CST 14: SAI2_COF*AI2/AI3+ SAI_CST 15: SAI1_COF*AI1/AI3+ SAI_CST	1	0	×
F4.4.52	Virtual input combination coefficient 1 (SAI_COF1)	0.01~500.00	0.01	1.00	×
F4.4.53	Virtual input combination coefficient 2 (SAI_COF2)	0.01~500.00	0.01	1.00	×
F4.4.54	Virtual input combination constant (SAI_CST)	-4080~4080	1	0	×

### 6.2.23 HOPPING FREQUENCY

Function Code	Name	Setting Range and Description	Minimum Unit	Factory Default	Change Limit
F5.0.00	Hopping frequency 1	0.0~[F0.1.21]	0.01	0.0	×
F5.0.01	Range of hopping frequency 1	0.0~10.00Hz	0.01	0.0	×
F5.0.02	Hopping frequency 2	0.0~[F0.1.21]	0.01	0.0	×
F5.0.03	Range of hopping frequency 2	0.0~10.00Hz	0.01	0.0	×
F5.0.04	Hopping frequency 3	0.0~[F0.1.21]	0.01	0.0	×
F5.0.05	Range of hopping frequency 3	0.0~10.00Hz	0.01	0.0	×

## 6.2.24 BUILT-IN AUXILIARY TIMER

Function Code	Name	Setting Range and Description	Minimum Unit	Factory Default	Change Limit
F5.1.06	Timer 1 (UT1) operating mode (H)	<p><b>___ X: Clock selection</b>            0: 1ms    1: 1Sec.    2: 1min.            3: Timer 1 cycle reaching pulse (effective for UT2, UT3)            4: Timer 2 cycle reach pulse (only effective for UT3)</p> <p><b>___ X_: Start and stop</b>            0: Multifunctional terminal triggering start (Edge triggering/ Function No. 52~54)            1: Stop→Run status change triggering (edge triggering)            2: Run→Stop status change triggering (edge triggering)            3: Synchronously started with timer 1 (effective for UT2, UT3)            4: Timer 1 cycle reach pulse (effective for UT2, UT3)            5: Timer 2 cycle reach pulse (effective for UT3)</p> <p><b>_ X _: Timer status resetting (timer value and status )</b>            0: Multifunctional terminal (Function No. 55~57)            1: Automatic resetting when the cycle is reached            2: Automatic resetting when timer is stopped</p> <p><b>X _ _: Timing cycle</b>            0: Single-cycle timing (resetting and retriggering required)            1: Multi-cycle timing (start again after auto clearing)</p>			
F5.1.07	Timer 2 (UT2) operating mode (H)		1	0000	×
F5.1.08	Timer 3 (UT3) operating mode(H)				
F5.1.09	Timer 1 timing cycle	0~65535 (clock cycle)	1	30000	
F5.1.10	Timer 1 comparative threshold value	0~[F5.1.09]	1	10000	
F5.1.11	Timer 2 timing cycle	0~65535 (clock cycle)	1	30000	
F5.1.12	Timer 2 comparative threshold value	0~[F5.1.11]	1	10000	
F5.1.13	Timer 3 timing cycle	0~65535 (clock cycle)	1	30000	
F5.1.14	Timer 3 comparative threshold value	0~[F5.1.13]	1	10000	

Function Code	Name	Setting Range and Description	Minimum Unit	Factory Default	Change Limit
F5.1.15	Timer door control signal selection	<p>___X: <b>Timer 1(UT1) gated signal</b></p> <p>0: No gating function</p> <p>1: Multifunctional terminal (Function No. 58)</p> <p>2: Timer 1 comparative value reached (effective for UT2, UT3)</p> <p>3: Timer 1 cycle reached (effective for UT2, UT3)</p> <p>4: Timer 2 comparative value reached (effective for UT3)</p> <p>5: Timer 2 cycle reached (effective for UT3)</p> <p>___X_: <b>Timer 2 (UT2) gated signal selection</b></p> <p>The same as above,</p> <p>1: Multifunctional terminal (Function No. 59)</p> <p>_X_: <b>Timer 3 (UT3) gated signal selection</b></p> <p>The same as above,</p> <p>1: Multifunctional terminal (Function No. 60)</p>	1	0000	
F5.1.16	Timer 1 output signal (H)	<p>___X: <b>Output signal1</b></p> <p>0: Comparative value reached (0.5s pulse)</p> <p>1: Comparative value reached (level)</p> <p>2: Comparative value reached and reversed</p> <p>3: Cycle reached (0.5s pulse)</p> <p>4: Cycle reached (level)</p> <p>5: Cycle reached and reversed</p> <p>6: Comparative value or cycle reached and reversed</p> <p>___X_: <b>Output signal 2</b></p> <p>The same as above</p>	1	0041	
F5.1.17	Timer 2 output signal (H)	<p>___X_: <b>Output signal 2</b></p> <p>The same as above</p>	1	0041	
F5.1.18	Timer 3 output signal (H)	<p>_X_: <b>Reserved</b></p> <p>X___: <b>Reserved</b></p>	1	0041	
F5.1.19	Timer value display unit(H)	<p>___X: <b>Timer 1</b></p> <p>0: Clock unit (original value)</p> <p>1: Sec.      2: Min.      3: H.</p> <p>___X_: <b>Timer 2</b></p> <p>The same as above</p> <p>_X_: <b>Timer 3</b></p> <p>The same as above</p>	1	0000	

## 6.2.25 BUILT-IN AUXILIARY COUNTER

Function Code	Name	Setting Range and Description	Minimum Unit	Factory Default	Change Limit
F5.2.20	Counter 1 operating mode (H)	<b>___ X: Counter pulse selection (Function No. 44, 45)</b> 0: Multifunctional terminal "Void→effective" 1: Multifunctional terminal "effective→void" 2: Aforesaid two conditions are both effective <b>___ X_: Starting mode</b> 0: Start immediately after power-on (no trigger start) 1: Multifunctional terminal trigger (Function No. 46-47) 2: Stop→Run status change triggering (edge triggering) 3: Run→Stop Status change triggering (edge triggering) <b>_ X _: Counter resetting source</b> 0: Multifunctional terminal (Function No.48~49) 1: Set value 1 reaches auto resetting 2: Set value 2 reaches auto resetting <b>X _ _: Counter save data when power off</b> 0: Counter not save data when power off 1: Counter save data when power off	1	0000	
F5.2.21	Counter 2 operating mode (differed from timer: in case of no resetting, continue counting until overflow, and then continue to count from 0) (H)	0: Multifunctional terminal "Void→effective" 1: Multifunctional terminal "effective→void" 2: Aforesaid two conditions are both effective <b>___ X_: Starting mode</b> 0: Start immediately after power-on (no trigger start) 1: Multifunctional terminal trigger (Function No. 46-47) 2: Stop→Run status change triggering (edge triggering) 3: Run→Stop Status change triggering (edge triggering) <b>_ X _: Counter resetting source</b> 0: Multifunctional terminal (Function No.48~49) 1: Set value 1 reaches auto resetting 2: Set value 2 reaches auto resetting <b>X _ _: Counter save data when power off</b> 0: Counter not save data when power off 1: Counter save data when power off	1	0000	
F5.2.22	Set value 1 of counter 1	0~65535	1	1000	
F5.2.23	Set value 2 of counter 1	0~65535	1	2000	
F5.2.24	Set value 1 of counter 2	0~65535	1	1000	
F5.2.25	Set value 2 of counter 2	0~65535	1	2000	
F5.2.26	Counter 1 output signal(H)	<b>___ X: Output signal1</b> 0: Reach set value 1 (0.5 Sec.pulse) 1: Reach set value 2 (level) 2: Set value 1 reached and reversed 3: Reach set value 2 (0.5 Sec.pulse) 4: Reach set value 5 (level) 5: Set value 1reached and reversed 6: Set value 1 or set value 2 reached and reversed <b>___ X_: Output signal 2</b> The same as above <b>_ X _: Reserved</b> <b>X _ _: Reserved</b>	1	0000	
F5.2.27	Counter 2 output signal(H)	0: Reach set value 1 (0.5 Sec.pulse) 1: Reach set value 2 (level) 2: Set value 1 reached and reversed 3: Reach set value 2 (0.5 Sec.pulse) 4: Reach set value 5 (level) 5: Set value 1reached and reversed 6: Set value 1 or set value 2 reached and reversed <b>___ X_: Output signal 2</b> The same as above <b>_ X _: Reserved</b> <b>X _ _: Reserved</b>	1	0000	

## 6.2.26 AUXILIARY FUNCTIONS

Function Code	Name	Setting Range and Description	Minimum Unit	Factory Default	Change Limit
F5.3.28	Priority selection of frequency (revolution) command source	<p>___X: 1<sup>st</sup> priority (highest)</p> <p>0: No definition</p> <p>1: Process PID output</p> <p>2: Compensation PID output</p> <p>3: Swing frequency running command</p> <p>4: Automatic multi-stage frequency running command</p> <p>5: Multi-stage operating frequency selected by external terminals</p> <p>6: Revolution setting channel (F8.0.00)</p> <p>7: Frequency Setting channel (F0.1.16)</p> <p>___X_: 2<sup>nd</sup> priority The same as above</p> <p>__X__: 3<sup>rd</sup> priority The same as above</p> <p>X___: 4<sup>th</sup> priority The same as above</p>	1	0000	×
F5.3.29	Lower limiting frequency action mode	<p>0: Output 0 frequency when it is below the lower limiting frequency</p> <p>1: Output the lower limiting frequency when it is below the lower limiting frequency</p>	1	0	
F5.3.30	Automatic voltage regulation (effective in V/F mode)	<p>0: Closed                    1: Effective</p> <p>2: Deceleration process void</p>	1	0	
F5.3.31	Automatic energy -saving operation	<p>0: Void                    1: Effective</p> <p>(effective for asynchronous motors)</p>	1	0	
F5.3.32	Magnetic flux brake	<p>0: Void                    1: Effective</p> <p>2: Multifunctional terminal effective (Function No. 65)</p>	1	0	
F5.3.33	Magnetic flux braking strength	30~120%	1	☆	
F5.3.34	Voltage over modulation	<p>0: Void                    1: Effective</p>	1	1	
F5.3.35	Use ratio of dynamic braking	50~100(%)	1	100	
F5.3.36	Level of dynamic braking starting action	700~760V	1	720	
F5.3.37	Vibration suppression coefficient	<p>0.0, 0.01~10.00</p> <p>(only effective in VF control mode)</p>	0.01	0.0	
F5.3.38	Load dynamic balance function	<p>0: Void                    1: Effective</p> <p>2: Multifunctional terminal effective (Function No. 38)</p>	1	0	
F5.3.39	Reference source for dynamic balance load	<p>0: Digital setting (F5.3.40)</p> <p>1: AI1 input    2: AI2 input</p> <p>3: AI3 input    4: Fieldbus set value 1</p> <p>5: Compensation PID output</p>	1	0	
F5.3.40	Reference value for dynamic balance load	0.0~ 200.0 (%)	0.1	100.0	
F5.3.41	Dynamic balance adjustment gain	0.00~100.00	0.01	50.00	
F5.3.42	Dynamic balance adjustment limit	0.00~100.00 (%)	0.01	1.00	



## 6.2.27 MOTOR TEMPERATURE DETECTION

Function Code	Name	Setting Range and Description	Minimum Unit	Factory Default	Change Limit
F5.4.43	Motor temperature sensor	0: None 1: 1 X PT100 2: 2 X PT100 3: 3 X PT100 4: PTC sensor 5: Thermoswitch (normally closed) 6: Thermoswitch (normally open)	1	0	
F5.4.44	Sensor current source providing terminal (exceeding parameter)	0: None 1: AO1 2: AO2			
F5.4.45	Temperature input channel	0: None 1: AI1 input (PT100 or PTC) 2: AI3 input (PT100 or PTC) 3: DI1~DI9 (thermoswitch)	1	0	
F5.4.46	Alarm action threshold value	-10.0~500.0 (0~5000 Ω/PTC)	0.1	110.0	
F5.4.47	Protection action threshold value	-10.0~500.0 (0~5000 Ω/PTC)	0.1	130.0	

## 6.2.28 MULTI-STAGE FREQUENCY SETTING

Function Code	Name	Setting Range and Description	Minimum Unit	Factory Default	Change Limit
F6.0.00	1st operating frequency	[F0.1.22]~[F0.1.21]	0.01	5.00	
F6.0.01	2nd operating frequency	[F0.1.22]~[F0.1.21]	0.01	10.00	
F6.0.02	3rd operating frequency	[F0.1.22]~[F0.1.21]	0.01	15.00	
F6.0.03	4th operating frequency	[F0.1.22]~[F0.1.21]	0.01	20.00	
F6.0.04	5th operating frequency	[F0.1.22]~[F0.1.21]	0.01	25.00	
F6.0.05	6th operating frequency	[F0.1.22]~[F0.1.21]	0.01	30.00	
F6.0.06	7th operating frequency	[F0.1.22]~[F0.1.21]	0.01	35.00	
F6.0.07	8th operating frequency	[F0.1.22]~[F0.1.21]	0.01	40.00	
F6.0.08	9th operating frequency	[F0.1.22]~[F0.1.21]	0.01	45.00	
F6.0.09	10th operating frequency	[F0.1.22]~[F0.1.21]	0.01	50.00	
F6.0.10	11th operating frequency	[F0.1.22]~[F0.1.21]	0.01	25.00	
F6.0.11	12th operating frequency	[F0.1.22]~[F0.1.21]	0.01	5.00	
F6.0.12	13th operating frequency	[F0.1.22]~[F0.1.21]	0.01	15.00	
F6.0.13	14th operating frequency	[F0.1.22]~[F0.1.21]	0.01	35.00	
F6.0.14	15th operating frequency	[F0.1.22]~[F0.1.21]	0.01	50.00	

## 6.2.29 SIMPLE PROGRAMMABLE MULTI-STAGE OPERATION

Function Code	Name	Setting Range and Description	Minimum Unit	Factory Default	Change Limit
F6.1.15	Selection of programmable multi-stage speed operation mode (H)	<p><b>___X: Function selection</b>            0: Function closed            1: Multi-stage frequency/revolution operation effective            2: Multi-stage frequency/revolution operation condition effective (Function No. 23)            3: Multi-stage PID setting operation effective            4: Multi-stage PID setting operation condition effective (Function No. 23)</p> <p><b>__X_: Operation mode</b>            0: Single cycle            1: Single cycle stop mode            2: Continuous cycle            3: Continuous cycle stop mode            4: Keeping the final value            5: Keeping the final value stop mode</p> <p><b>_X__: Selection of breakpoint/stop recovery mode</b>            0: Restore running at the first stage            1: Start running at the interruption time (effective for multi-stage frequency/revolution operation)            2: Start running at the stage of interruption</p> <p><b>X___: Power-off status storage</b>            0: Not stored                      1: Stored</p>	1	0000	×
F6.1.16	Stage 1 setting (H)	<p><b>___X: Hz of each stage</b>            0: Multi-stage frequency setting 1~15/            Process PID multi-stage setting 1~7</p> <p>1: Frequency command (F0.1.16)/            Process PID setting (F7.0.01)</p> <p><b>__X_: Direction setting</b>            0: FWD            1: REV</p> <p>2: Determined by the running command channel</p> <p><b>_X__: Accele/decele of each stage</b>            0: Acceleration and deceleration time 1            1: Acceleration and deceleration time 2            2: Acceleration and deceleration time 3            3: Acceleration and deceleration time 4</p> <p><b>X___: Each stage time unit</b>            0: Sec.                              1: Min.</p>	1	0000	
F6.1.17	Stage 2 setting (H)		1	0000	
F6.1.18	Stage 3 setting (H)		1	0000	
F6.1.19	Stage 4 setting (H)		1	0000	
F6.1.20	Stage 5 setting (H)		1	0000	
F6.1.21	Stage 6 setting (H)		1	0000	
F6.1.22	Stage 7 setting (H)		1	0000	
F6.1.23	Stage 8 setting (H)		1	0000	
F6.1.24	Stage 9 setting (H)		1	0000	
F6.1.25	Stage 10 setting (H)		1	0000	
F6.1.26	Stage 11 setting (H)		1	0000	
F6.1.27	Stage 12 setting (H)		1	0000	
F6.1.28	Stage 13 setting (H)		1	0000	
F6.1.29	Stage 14 setting (H)		1	0000	
F6.1.30	Stage 15 setting (H)		1	0000	
F6.1.31	Stage 1 running time	0.0~6500.0(Sec./Min.)	0.1	0.0	
F6.1.32	Stage 2 running time	0.0~6500.0(Sec./Min.)	0.1	0.0	
F6.1.33	Stage 3 running time	0.0~6500.0(Sec./Min.)	0.1	0.0	
F6.1.34	Stage 4 running time	0.0~6500.0(Sec./Min.)	0.1	0.0	

Function Code	Name	Setting Range and Description	Minimum Unit	Factory Default	Change Limit
F6.1.35	Stage 5 running time	0.0~6500.0(Sec./Min.)	0.1	0.0	
F6.1.36	Stage 6 running time	0.0~6500.0(Sec./Min.)	0.1	0.0	
F6.1.37	Stage 7 running time	0.0~6500.0(Sec./Min.)	0.1	0.0	
F6.1.38	Stage 8 running time	0.0~6500.0(Sec./Min.)	0.1	0.0	
F6.1.39	Stage 9 running time	0.0~6500.0(Sec./Min.)	0.1	0.0	
F6.1.40	Stage 10 running time	0.0~6500.0(Sec./Min.)	0.1	0.0	
F6.1.41	Stage 11 running time	0.0~6500.0(Sec./Min.)	0.1	0.0	
F6.1.42	Stage 12 running time	0.0~6500.0(Sec./Min.)	0.1	0.0	
F6.1.43	Stage 13 running time	0.0~6500.0(Sec./Min.)	0.1	0.0	
F6.1.44	Stage 14 running time	0.0~6500.0(Sec./Min.)	0.1	0.0	
F6.1.45	Stage 15 running time	0.0~6500.0(Sec./Min.)	0.1	0.0	

### 6.2.30 SWING FREQUENCY OPERATION

Function Code	Name	Setting Range and Description	Minimum Unit	Factory Default	Change Limit
F6.2.46	Function selection (H)	<p><b>__ X:</b> Function Setting  0: Function closed  1: Function effective  2: Terminal selectivity effective (Function No.24)</p> <p><b>__ X _:</b> Stop restart mode  0: Start with the memory status before stop  1: Restart</p> <p><b>_ X _:</b> Swing control  0: Fixed swing (relative maximum frequency)  1: Variable swing (relative central frequency)</p> <p><b>X _ _:</b> Status storage  0: Not saved after power-off, and run again after restart  1: Save the status after power-off, and run again from the saved status</p>	1	0000	×
F6.2.47	Swing frequency preset frequency	0.0~[F0.1.21]	0.01	10.00	
F6.2.48	Preset frequency waiting time	0.0~6000.0Sec.	0.1	0.0	
F6.2.49	Swing frequency amplitude	0.0~50.0(%)	0.1	10.0	
F6.2.50	Sudden jump frequency	0.0~50.0(%)	0.1	10.0	
F6.2.51	Triangular wave rising time	0.1~1000.0Sec.	0.1	10.0	
F6.2.52	Triangular wave decreasing time	0.1~1000.0Sec.	0.1	10.0	
F6.2.53	Frequency setting in the center of the swing frequency	0.0~[F0.1.21]	0.01	10.00	

### 6.2.31 PROCESS PID (4MS CONTROL CYCLE)

Function Code	Name	Setting Range and Description	Minimum Unit	Factory Default	Change Limit
F7.0.00	Process PID function selection	<p><b>___ X: Process PID controller selection</b>            0: Process PID closed            1: Unconditionally effective            2: External multifunctional terminal selectivity effective (Function No. 22)</p> <p><b>__ X_: Reserved</b></p> <p><b>_ X_: Process PID controller output</b>            0: Frequency/revolution set value            1: Independent PID (created by AO terminal output or as a torque)</p> <p><b>X___: Superposition mode of main and auxiliary, consult the frequency benchmark</b>            0: Upper limit of frequency channel            1: Set value of superposition channel            2: Set value of superposition channel/ upper limit frequency-superposition channel set</p>	1	0000	×
F7.0.01	Process PID set value selection	0: PID Reference Channel 1 1: PID Reference Channel 2 2: Select Channel Via Terminal (Function No. 31) 3: Channel 1 + Channel 2 4: Channel 1 - Channel 2 5: Channel 1 * (1+ Channel 2/100.0) 6: Channel 1 * (1- Channel 2/100.0) 7: Channel 1 * Channel 2/100.0	1	0	
F7.0.02	Process PID setting channel 1	0: PID Internal Reference (F7.0.08) (power-off save)	1	0	×
F7.0.03	Process PID setting channel 2	1: Keypad Potentiometer 2: Analog input AI1 3: Analog input AI2 4: Analog input AI3 5: Remote UP/DW 1 (clear after stop) 6: Remote UP/DW 2 (maintained after stop and saved after power-off) 7: Analog input AI3 8: Remote UP/DW 3(clear after stop) 9: U Remote UP/DW 4 (maintained after stop and saved after power-off) 10: MODBUS value 1 11: MODBUS value 2	1	0	×
F7.0.04	Analog input quantity corresponding to 0% setting (Channel 1)	0.0V~[F7.0.05]/ AI2: 0.0mA~[F7.0.05]	0.01	0.0	
F7.0.05	Analog input quantity corresponding to 100% setting (Channel 1)	[F7.0.04]~10.00/AI2: [F7.0.04]~20.00mA	0.01	10.00	

Function Code	Name	Setting Range and Description	Minimum Unit	Factory Default	Change Limit
F7.0.06	Analog input quantity corresponding to 0% setting (Channel 2)	0.0V~[F7.0.07]/ AI2: 0.0mA~[F7.0.07]	0.01	0.0	
F7.0.07	Analog input quantity corresponding to 100% setting (Channel 2)	[F7.0.06]~10.00/AI2: [F7.0.06]~20.00mA	0.01	10.00	
F7.0.08	Process PID internal digital preset	-100.0~100.0(%)	0.1	0.0	
F7.0.09	Process PID feedback value selection	0: PID Actual Value 1 1: PID Actual Value 2 2: Select Via Remote Input (Function No. 32) 3: Actual Value 1+ Actual Value 2 4: Actual Value 1- Actual Value 2 5: Actual Value 1* Actual Value 2/100.0 6: 100.0* Actual Value 1/ Actual Value 2 7: Min. { Actual Value 1, Actual Value 2} 8: Max. { Actual Value 1, Actual Value 2} 9: $\sqrt{( \text{Actual Value 1} - \text{Actual Value 2} )}$ 10: $\sqrt{( \text{Actual Value 1} )} + \sqrt{( \text{Actual Value 2} )}$	1	0	
F7.0.10	Process PID feedback channel 1	0: Analog input AI1 1: Analog input AI2	1	0	
F7.0.11	Process PID feedback channel 2	2: Analog input AI3 3: Analog input AI3 dual polarity PID feedback 4: Fin pulse input	1	0	
F7.0.12	Analog feedback quantity corresponding to 0% feedback (feedback channel 1)	0.0~[F7.0.13] /AI2: 0.0mA~[F7.0.13]	0.01	0.0	
F7.0.13	Analog feedback quantity corresponding to 100% feedback (feedback channel 1)	[F7.0.12]~10.00V /AI2: [F7.0.12]~20.00mA	0.01	5.00	
F7.0.14	Analog feedback quantity corresponding to 0% feedback (feedback channel 2)	0.0~[F7.0.15]/AI2: 0.0mA~[F7.0.15]	0.01	0.0	
F7.0.15	Analog feedback quantity corresponding to 100% feedback ( feedback channel 2)	[F7.0.14]~10.00V /AI2: [F7.0.14]~20.00mA	0.01	5.00	
F7.0.16	Feedback multiplication factor (e.g. differential voltage calculate flow rate with differential voltage)	0.01~100.00	0.01	1.00	
F7.0.17	Proportional gain	0.0~100.00	0.01	2.00	
F7.0.18	Integration time	0.0, 0.1~1000.0Sec.	0.1	20.0	
F7.0.19	Differential coefficient	0.0, 0.01~10.00	0.01	0.0	

Function Code	Name	Setting Range and Description	Minimum Unit	Factory Default	Change Limit
F7.0.20	Differential inertia filtering time	0.01~100.00Sec.	0.01	10.00	
F7.0.21	PID controller characteristics configuration	<p>___X: <b>Deviation polarity</b>  0: Positive deviation  1: Negative deviation (negation)</p> <p>__X_: <b>Output polarity</b>  0: Single polarity  1: Dual polarity (the symbol can be reversed)</p> <p>_X_: <b>Action when PID removed</b>  0: PID control closed  1: PID output held up and current setting status is maintained.</p>	1	0000	
F7.0.22	Permitted static deviation (relative 100% setting)	0.0~20.0%	0.1	5.0	
F7.0.23	PID output preset (at the time of output frequency as compared to the upper limiting frequency)	0.0~100.0 (%)	0.01	0.0	
F7.0.24	Preset hold time before PID starting	0.0~3600.0Sec.	0.1	0.0	
F7.0.25	Actual sensor value (range)corresponding to 100% feedback	0.01~100.00	0.01	1.00	
F7.0.26	Actual sensor value corresponding to 0% feedback	-100.00~100.00	0.01	0.0	

### 6.2.32 PROCESS PID MULTI-STAGE SETTING

Function Code	Name	Setting Range and Description	Minimum Unit	Factory Default	Change Limit
F7.1.27	Process PID multi-stage preset 1	-100.0~100.0 (%)	0.1	0.0	
F7.1.28	Process PID multi-stage preset 2	-100.0~100.0 (%)	0.1	0.0	
F7.1.29	Process PID multi-stage preset 3	-100.0~100.0 (%)	0.1	0.0	
F7.1.30	Process PID multi-stage preset 4	-100.0~100.0 (%)	0.1	0.0	
F7.1.31	Process PID multi-stage preset 5	-100.0~100.0 (%)	0.1	0.0	
F7.1.32	Process PID multi-stage preset 6	-100.0~100.0 (%)	0.1	0.0	
F7.1.33	Process PID multi-stage preset 7	-100.0~100.0 (%)	0.1	0.0	

### 6.2.33 PROCESS PID SLEEP FUNCTION

(Effective when PID output is used as the frequency command)

Function Code	Name	Setting Range and Description	Minimum Unit	Factor y Default	Change Limit
F7.2.34	Sleep function	0: Closed            1: Enabled 2: Enabled when the multifunctional input selection is effective (Function No. 33)	1	0	
F7.2.35	Sleep frequency	0.0~[F0.1.21]	0.01	0.0	
F7.2.36	Sleep delay	0.1~3600.0Sec.	0.1	60.0	
F7.2.37	Awakening deviation (compared with the set value )	0.0~100.0(%)	0.1	25.0	
F7.2.38	Awakening delay	0.1~3600.0Sec.	0.1	60.0	

### 6.2.34 REVOLUTION SETTING AND FEEDBACK

Function Code	Name	Setting Range and Description	Minimum Unit	Factory Default	Change Limit
F8.0.00	Revolution setting channel (only applicable to VC and SVC mode)	0: Set by frequency setting parameter (F0.1.16) 1: Digital setting (F8.0.03) (maintained after stop and saved after power-off) 2: Keypad potentiometer 3: Analog inputAI1 4: Analog inputAI2 5: Analog inputAI3 (dual polarity) 6: Frequency input (Fin) 7: MODBUS Fieldbus set value 1 8: MODBUS Fieldbus set value 2 9: Virtual analog input SAI1 10: Virtual mode input SAI2	1	0	
F8.0.01	Minimum set signal corresponding revolution	0~60*[F0.1.21] / pairs of motor poles (rpm)	1	0	
F8.0.02	Maximum set signal corresponding revolution	0~60*[F0.1.21] / pairs of motor poles (rpm)	1	1500	
F8.0.03	Revolution Digital setting	0~60*[F0.1.21] / pairs of motor poles (rpm)	1	0	
F8.0.04	Revolution feedback channel	0: Decoder (PG card needs to be equipped) 1: Single pulse input (Fin port) 2: Analog input AI1 3: Analog input AI2 4: Analog input AI3 (dual polarity)	1	0	×
F8.0.05	Pulse of decoder per revolution (PG)	1~8192	1	1024	×
F8.0.06	PG rotation direction (Effective for PG card)	0: Phase A leads 1: Phase B leads	1	0	×

Function Code	Name	Setting Range and Description	Minimum Unit	Factory Default	Change Limit
F8.0.07	PG zero pulse (Z pulse)	0: Void 1: Effective	1	0	×
F8.0.08	Decoder type	0: ABZ incremental decoder 1: ABZUVW incremental type 2: SIN COS type 3: Rotary transformer	1	0	×
F8.0.09	PG revolution check cycle	1~5ms	1	2ms	
F8.0.10	Missing detection and action of speed detection signal	<p>___ X: <b>Speed signal detection</b></p> <p>0: Not detect 1: Detect and treat</p> <p>___ X_: <b>Speed signal detection action</b></p> <p>0: Fault alarm and free stop 1: Continue running after switching to SVC control mode and then display the alarm information (reserved) 2: DC bind-type brake (reserved)</p>	1	0001	×
F8.0.11	Judging time for speed detection signal missing	0.01~5 .00Sec.	0.01	2.00	
F8.0.12	Wire breakage zero speed signal level (as compared to the maximum set speed)	0~20.0 (%)	0.1	0.0	
F8.0.13	Speed measuring loop wire breakage detection flexibility (as compared to the maximum set speed)	0.1~100.0	0.1	5.0	
F8.0.14	Detection revolution filtering time coefficient	0(Closed), 1~50ms	1	2ms	
F8.0.15	The minimum revolution corresponding to the feedback signal (not PG)	0~30000rpm	1	0	
F8.0.16	The maximum revolution corresponding to the feedback signal (not PG)	0~30000rpm	1	1500	
F8.0.17	Feedback revolution ratio (motor shaft speed: measured shaft speed)	0.010~50.000	0.001	1.000	×

### 6.2.35 REVOLUTION CLOSED-LOOP PARAMETER

Function Code	Name	Setting Range and Description	Minimum Unit	Factory Default	Change Limit
F8.1.18	Controller PID selection	<p>0: Single PID parameter (the second group of parameters are effective separately)</p> <p>1: Dual PID parameter (hysteresis switching)</p> <p>2: Dual PID parameter (continuous switching)</p>	1	2	



Function Code	Name	Setting Range and Description	Minimum Unit	Factory Default	Change Limit
F8.1.19	PID parameter switching lower limiting revolution (ASR1 group parameter low revolution effective)	0~[F8.1.20]	1	100	
F8.1.20	PID parameter switching upper limiting revolution (ASR2 group parameter high revolution effective)	[F8.1.19]~60*[F0.1.21]/ pairs of motor poles (rpm)	1	300	
F8.1.21	Proportional gain 1 (ASR-P1)	0.10~2.00	0.01	1.00	
F8.1.22	Integration time 1 (ASR-I1)	0.0, 0.01~50.00 Sec.	0.01	1.00	
F8.1.23	Differential coefficient 1 (ASR-D1)	0.0, 0.01~10.00	0.01	0.0	
F8.1.24	Differential output filtering constant 1 (ASR-DT1)	0.10~5.00 Sec.	0.01	1.00	
F8.1.25	Proportional gain 2 (ASR-P2)	0.10~2.00	0.01	0.80	
F8.1.26	Integration time 2 (ASR-I2)	0.0, 0.01~50.00 Sec.	0.01	2.50	
F8.1.27	Differential coefficient 2 (ASR-D2)	0.0, 0.01~10.00	0.01	0.0	
F8.1.28	Differential output filtering constant 2 (ASR-DT2)	0.10~10.00 Sec.	0.01	1.00	
F8.1.29	Adjustor output upper limit amplitude	0.0~250.0%	0.1	190.0%	
F8.1.30	Adjustor output lower limit amplitude	-250.0~0.0%	0.1	-190.0%	
F8.1.31	Time span of regulator export filtering	0, 0.1~50.0ms	0.1	0	

## 6.2.36 PROTECTION PARAMETER

Function Code	Name	Setting Range and Description	Minimum Unit	Factory Default	Change Limit
F8.2.32	Excessive rotation(DEV)	0: No action	1	0	×
F8.2.33	Over speed (OS) protection	1: Alarm free stop 2: Alarm deceleration stop 3: Alarm continuing running	1	1	×
F8.2.34	Over speed protection limit (DEV)	0.0~50.0% (as compared to upper limiting frequency)	0.1	20.0%	
F8.2.35	Over speed protection period (DEV)	0.0~10.00Sec.	0.01	10.00	
F8.2.36	Over speed protection value (OS)	0.0~150.0% (as compared to upper limiting frequency)	0.1	120.0%	
F8.2.37	Over speed protection time (OS)	0.0~2.00Sec.	0.01	0.10	
F8.2.38	SVC rotating speed estimate gain factor	0.10 ~ 10.00	0.01	1.00	

## 6.2.37 TORQUE CONTROL

Function Code	Name	Setting Range and Description	Minimum Unit	Factory Default	Change Limit
F8.3.39	Torque control activation	0: Void      1: Effective 2: Multifunctional terminal selection effective (Function No. 34)	1	0	×
F8.3.40	Torque control reference (selecting the command direction)	0: Digital setting (F8.3.41) 1: Panel shuttle potentiometer setting 2: Analog inputA1 3: Analog inputA2 4: Analog inputA3 5: Analog inputA3 (dual polarity) 6: Frequency signal input (Fin) 7: Process PID output 8: Compensation PID output 9: MODBUS Fieldbus set value 1 10: MODBUS Fieldbus set value 2 11: Virtual analog input SAI1 12: Virtual mode input SAI2	1	0	
F8.3.41	Torque digital setting	-250.0~250.0 (%)	0.1	0.0	
F8.3.42	Torque digital rise time	0.0~50.000Sec.	0.001	0.010	
F8.3.43	Torque digital fall time	0.0~50.000Sec.	0.001	0.010	
F8.3.44	Revolution limiting setting	<b>___X: FWD revolution limiting setting source</b> 0: Setting of FWD revolution limiting value (F8.3.45) 1: Determination of frequency Setting channel 1 (F0.2.25) <b>__X_: Reserved</b> <b>_X__: REV Revolution limiting setting source</b> 0: Setting of REV revolution limiting value (F8.3.46) 1: Determination of frequency Setting channel 2 (F0.2.26)	1	0000	
F8.3.45	FWD revolution limiting value	0~60*[F0.1.21]/pairs of motor poles (rpm)	1	1500	
F8.3.46	REV revolution limiting value	0~60*[F0.1.21]/pairs of motor poles (rpm)	1	1500	
F8.3.47	Setting of torque set value limit	<b>___X: Minimum torque selection source (negative torque limit)</b> 0: Minimum torque set value 1 (F8.3.48) 1: Minimum torque set value 2 (F8.3.49) 2: Multifunctional selection terminal setting 1 or 2 3: A1 set value 4: A2 set value 5: MODBUS Fieldbus set value 1	1	0000	

Function Code	Name	Setting Range and Description	Minimum Unit	Factory Default	Change Limit
		6: MODBUS Fieldbus set value 2 <b>__ X _: Reserved</b> <b>_ X _: Maximum torque selection source</b> 0: Maximum torque set value 1 (F8.3.50) 1: Maximum torque set value 2 (F8.3.51) 2: Multifunctional selection terminal setting 1 or 2 (Function No. 36) 3: AI1 set value 4: AI2 set value 5: MODBUS Fieldbus set value 1 6: MODBUS Fieldbus set value 2			
F8.3.48	Minimum torque limit 1	-250.0~0.0%	0.1	-200.0	
F8.3.49	Minimum torque limit 2	-250.0~0.0%	0.1	-200.0	
F8.3.50	Maximum torque limit 1	0.0~250.0%	0.1	200.0	
F8.3.51	Maximum torque limit 2	0.0~250.0%	0.1	200.0	
F8.3.52	Torque zero offset	-25.0~25.0%	0.1	0.0	

### 6.2.38 COMPENSATION PID (RUNNING CYCLE: 1MS)

Function Code	Name	Setting Range and Description	Minimum Unit	Factory Default	Change Limit
F9.0.00	Compensation PID function	<b>___ X: Controller input</b> 0: Closed 1: Synchronously effective with inverter running command 2: Activated when the Multifunctional terminal is effective (Function No. 25) 3: Immediately effective after the inverter is powered on <b>__ X _: Reserved</b> <b>_ X _: Controller output</b> 0: Feed FWD compensation-added with the frequency integrator output, and the complementation ratio is set by parameter F9.0.01 1: Independent PID- the output can be set by the AO terminal output/torque. 2: Set PID-output used as frequency/ revolution command <b>X ___: feed forward compensate frequency benchmark</b> 0: Relative to the upper frequency 1: Relative to the frequency integrator output	1	0100	×
F9.0.01	Compensation proportion (as compared to upper limiting frequency)	0.0~100.0(%)	0.1	50.0	

Function Code	Name	Setting Range and Description	Minimum Unit	Factory Default	Change Limit
F9.0.02	Compensation PID controller feature configuration	<p>___ X: <b>Deviation polarity</b>  0: Positive deviation  1: Negative deviation (negation)</p> <p>___ X_: <b>Output polarity</b>  0: Single polarity  1: Dual polarity</p> <p>_ X _: <b>Loss of signal response</b>  0: PID control closed  1: PID output held on (maintaining current running setting)</p>	1	0010	
F9.0.03	Proportional gain 1	0.0~100.00	0.01	2.00	
F9.0.04	Integration time 1	0.0, 0.01~100.00Sec.	0.01	2.00	
F9.0.05	Differential coefficient 1	0.0, 0.01~10.00	0.01	0.0	
F9.0.06	Differential inertia filtering time 1	0.01~25.00Sec.	0.01	5.00	
F9.0.07	Compensation PID output inertia filtering time coefficient1	0.0, 0.01 ~ 20.00Sec.	0.01	1.00	
F9.0.08	Selection of compensation PID set value	0: Internal digital setting (F9.0.11) (auto save after power off) 1: Panel shuttle potentiometer preset value 2: Analog input AI1 3: Analog input AI2 4: Analog input AI3 5: UP/DW terminal (clear after stop) 6: UP/DW terminal (maintaining after stop and save after power-off) 7: MODBUS Fieldbus set value 1 8: MODBUS Fieldbus set value 2 9: Expansion communication set 1 10: Expansion communication set 1	1	0	
F9.0.09	Analog input minimum value	0.0V~[F9.0.10]/AI2: 0.0mA~[F9.0.10]	0.01	0.0	
F9.0.10	Analog input maximum value	[F9.0.09]~10.00/AI2: [F9.0.09]~20.00mA	0.01	10.00	
F9.0.11	PID internal reference	0.0~100.0 (%)	0.1	0.0	
F9.0.12	Selection of compensation PID feedback value	0: Analog input AI1 1: Analog input AI2 2: Analog input AI3 3: Output current 4: Output torque 5: Output power	1	0	
F9.0.13	Actual value analog input minimum	0.0V~[F9.0.14]/AI2: 0.0mA~[F9.0.14]	0.01	0.0	
F9.0.14	Actual value analog input maximum	[F9.0.13]~10.00/AI2: [F9.0.13]~20.00mA	0.01	10.00	

Function Code	Name	Setting Range and Description	Minimum Unit	Factory Default	Change Limit
F9.0.15	Actual value multiplication factor	0.01~100.00	0.01	1.00	
F9.0.16	Sensor value when actual value is 100%	0.01~100.00	0.01	1.00	
F9.0.17 ~ F9.0.20	Reserved				

### 6.2.39 COMPENSATION PID CONTROLLER PARAMETER SELECTION

Function Code	Name	Setting Range and Description	Minimum Unit	Factory Default	Change Limit
F9.1.21	Selection and switching of controller parameters	<p>___ X: PID parameters</p> <p>0: Single PID parameter 1: Dual PID parameters 2: Three PID parameters 3: Four PID parameters</p> <p>__ X_: PID parameter switching mode</p> <p>0: As per set value 1: As per feedback value 2: As per output frequency 3: Selected by multifunctional terminal (Function No.63 and 64)</p>	1	0020	
F9.1.22	Controller parameter switching transition coefficient	0.01 ~ 50.00	0.01	1.00	
F9.1.23	Lower limit for group 1/2 parameter switching	0.0~[F9.1.24]	0.1	0.0	
F9.1.24	Upper limit for group 1/2 parameter switching	[F9.1.23]~100.0 (%)	0.1	0.0	
F9.1.25	Lower limit for group 2/3 parameter switching	[F9.1.24]~[F9.1.26]	0.1	100.0	
F9.1.26	Upper limit for group 2/3 parameter switching	[F9.1.25]~100.0 (%)	0.1	100.0	
F9.1.27	Lower limit for group 3/4 parameter switching	[F9.1.26]~[F9.1.28]	0.1	100.0	
F9.1.28	Upper limit for group 3/4 parameter switching	[F9.1.27]~100.0 (%)	0.1	100.0	
F9.1.29	Proportional gain 2	0.0~100.00	0.01	2.00	
F9.1.30	Integration time 2	0.0, 0.01~100.00Sec.	0.01	2.00	
F9.1.31	Differential coefficient2	0.0, 0.01~10.00	0.01	0.0	
F9.1.32	Differential output filtering constant 2	0.01~25.00Sec.	0.01	5.00	
F9.1.33	Adjuster output filtering time coefficient 2	0.0, 0.01~20.00Sec.	0.01	1.00	
F9.1.34	Proportional gain 3	0.0~100.00	0.01	2.00	
F9.1.35	Integration time 3	0.0, 0.01~100.00Sec.	0.01	2.00	
F9.1.36	Differential coefficient3	0.0, 0.01~10.00	0.01	0.0	

Function Code	Name	Setting Range and Description	Minimum Unit	Factory Default	Change Limit
F9.1.37	Differential output filtering constant 3	0.01~25.00Sec.	0.01	5.00	
F9.1.38	Compensation PID output filtering time coefficient 3	0.0, 0.01~20.00Sec.	0.01	1.00	
F9.1.39	Proportional gain 4	0.0~100.00	0.01	2.00	
F9.1.40	Integration time 4	0.0, 0.01~100.00Sec.	0.01	2.00	
F9.1.41	Differential coefficient 4	0.0, 0.01~10.00	0.01	0.0	
F9.1.42	Differential output filtering constant 4	0.01~25.00Sec.	0.01	5.00	
F9.1.43	Compensation PID output filtering time coefficient 4	0.0, 0.01~20.00Sec.	0.01	1.00	



- 100% PID setting corresponds to 100% rated output current of the equipment, motor rated torque and rated power, so it needs to appropriately set up the feedback factor, output torque and power to be values with symbols according to actual application.

## 6.2.40 MODBUS FIELD BUS (STANDARD EXPANSION CARD CONFIGURATION)

Function Code	Name	Setting Range and Description	Minimum Unit	Factory Default	Change Limit
FA.0.00	Communication card connection and bus status	0: The communication card not connected 1: Standard MODBUS communication card connected 2: Listen only status 3: Communication interrupted	1	—	R
FA.0.01	Configuration parameter	— — X: <b>Baud rate selection</b> 0: 1200kbit/s 1: 2400kbit/s 2: 4800kbit/s 3: 9600kbit/s 4: 19200kbit/s 5: 38400kbit/s 6: 76800kbit/s — — X: <b>Data format</b> 0: 1-8-1-N, RTU 1: 1-8-1-E, RTU 2: 1-8-1-O, RTU 3: 1-8-2-N, RTU	1	0003	×
FA.0.02	The device station address	0~247(0 stands for broadcasting address)	1	1	×
FA.0.03	The device response delay	0~1000ms	1	5ms	
FA.0.04	Communication failure judging time	0.01~10.00Sec.	0.01	1.00	×
FA.0.05	Communication failure action	0: Deceleration stop 1: Run as per last received command	1	0	

Function Code	Name	Setting Range and Description	Minimum Unit	Factory Default	Change Limit
FA.0.06	Selection of communication configuration files	0: SUNFAR standard configuration file 1 1: SUNFAR standard configuration file 2 (Reserved)	1	0	
FA.0.07	—	—			

### 6.2.41 MAPPING ACCESS PARAMETER

Function Code	Name	Setting Range and Description	Minimum Unit	Factory Default	Change Limit
FA.1.08	Mapping application parameter 1 (H)	F0.00 ~ FF.55	1	F0.29	×
FA.1.09	Mapping application parameter 2 (H)	F0.00 ~ FF.55	1	F0.29	×
FA.1.10	Mapping application parameter 3 (H)	F0.00 ~ FF.55	1	F0.29	×
FA.1.11	Mapping application parameter 4 (H)	F0.00 ~ FF.55	1	F0.32	×
FA.1.12	Mapping application parameter 5 (H)	F0.00 ~ FF.55	1	F0.32	×
FA.1.13	Mapping application parameter 6 (H)	F0.00 ~ FF.55	1	F0.32	×
FA.1.14	Mapping status parameter 1 (H)	d0.00 ~ d1.49	1	d0.00	
FA.1.15	Mapping status parameter 2 (H)	d0.00 ~ d1.49	1	d0.01	
FA.1.16	Mapping status parameter 3 (H)	d0.00 ~ d1.49	1	d0.02	
FA.1.17	Mapping status parameter 4 (H)	d0.00 ~ d1.49	1	d0.03	
FA.1.18	Mapping status parameter 5 (H)	d0.00 ~ d1.49	1	d0.04	
FA.1.19	Mapping status parameter 6 (H)	d0.00 ~ d1.49	1	d0.05	
FA.1.20	Mapping status parameter 7 (H)	d0.00 ~ d1.49	1	d0.06	
FA.1.21	Mapping status parameter 8 (H)	d0.00 ~ d1.49	1	d0.07	
FA.1.22	Mapping status parameter 9 (H)	d0.00 ~ d1.49	1	d0.08	
FA.1.23	Mapping status parameter 10 (H)	d0.00 ~ d1.49	1	d0.09	
FA.1.24	—	—	—	—	

### 6.2.42 COMMUNICATION LINKAGE SYNCHRONOUS CONTROL

Function Code	Name	Setting Range and Description	Minimum Unit	Factory Default	Change Limit
FA.2.25	Coupling synchronous control options	<p>__ X: Selection of coupling function</p> <p>0: Void</p> <p>1: The device is the slave device</p> <p>2: The device is the master device</p> <p>__ X_: Linkage target value (Master device parameter)</p> <p>0: Proportional linkage of frequency /revolution set value</p> <p>1: Proportional linkage of frequency /revolution integrator output value</p> <p>_ X __: Coupling command (slave device parameter)</p> <p>0: Independent control of slave device(start and stop not linked)</p>	1	0310	×

Function Code	Name	Setting Range and Description	Minimum Unit	Factory Default	Change Limit
		1: Start and stop command linked 2: Start-stop/jog linked 3: Start-stop/jog/excitation linked 4: Start-stop/jog/excitation/DC bind-type brake/DC braking linked <b>X _ _ _ : linkage set choice</b> 0: Unit digit of the parameter confirm 1: The input of external terminal (function No.39)			
FA.2.26	Linkage setting proportion coefficient	0.010~10.000	0.001	1.000	
FA.2.27	Fine adjustment source for linkage proportion coefficient	0: No fine adjustment 1: Analog inputAI1 2: Analog inputAI2 3: Analog inputAI3	1	0	
FA.2.28	Slave device offset frequency/ Revolution	0: No offset 1: Determined by frequency setting source 1 2: Determined by frequency setting source 2	1	0	
FA.2.29	Linkage balancing function	0: Void 1: Current balancing 2: Torque balancing 3: Power balancing 4: Position synchronous balancing	1	0	
FA.2.30	Linkage balancing gain	0.001~10.000	0.001	1.000	
FA.2.31	Amplitude limiting of position synchronous balancing	0.10~10.00Hz	—	1.00	
FA.2.32	Reserved	—	—	—	

### 6.2.43 EXPANSION MULTIFUNCTIONAL INPUT TERMINAL

(ED11~ ED18)/ Effective after Connecting Expanding Accessories

Function Code	Name	Setting Range and Description	Minimum Unit	Factory Default	Change Limit
Fb.0.00	Expand multifunctional input terminal ED11	0~96	1	0	×
Fb.0.01	Expand multifunctional input terminal ED12	0~96	1	0	×
Fb.0.02	Expand multifunctional input terminal ED13	0~96	1	0	×
Fb.0.03	Expand multifunctional input terminal ED14	0~96	1	0	×
Fb.0.04	Expand multifunctional input terminal ED15	0~96	1	0	×
Fb.0.05	Expand multifunctional input terminal ED16	0~96	1	0	×



Function Code	Name	Setting Range and Description	Minimum Unit	Factory Default	Change Limit
Fb.0.06	Expand multifunctional input terminal EDI7	0~96	1	0	×
Fb.0.07	Expand multifunctional input terminal EDI8	0~96	1	0	×
Fb.0.08	Expand multifunctional terminal filtering time	1~50ms	1	5ms	
Fb.0.09	Expand multi function input terminal active level	<p>___X: EDI1-EDI4 terminal 0~F: 4-bit binary system, bit=0 power-on effective, 1 Disconnection Effective LED</p> <p>__X_: EDI5-EDI8 terminal The same as above</p> <p>_X__: Reserved</p> <p>XXXX: Reserved</p>	1	0000	×

### 6.2.44 EXPANSION MULTIFUNCTIONAL OUTPUT TERMINAL

(ED01/ ERO1~ ED04/ ERO4)/ Effective after Connecting Expanding Accessories

Function Code	Name	Setting Range and Description	Minimum Unit	Factory Default	Change Limit
Fb.1.10	Expand multifunctional input terminal EDO1	0~62	1	0	
Fb.1.11	Expand multifunctional input terminal EDO2	0~62	1	0	
Fb.1.12	Expand multifunctional input terminal EDO3	0~62	1	0	
Fb.1.13	Expand multifunctional input terminal EDO4	0~62	1	0	
Fb.1.14	Expand multifunctional input terminal ERO1	0~62	1	0	
Fb.1.15	Expand multifunctional input terminal ERO2	0~62	1	0	
Fb.1.16	Expand multifunctional input terminal ERO3	0~62	1	0	
Fb.1.17	Expand multifunctional input terminal ERO4	0~62	1	0	

### 6.2.45 SERVOCONTROL AND SCALE POSITIONING

Function Code	Name	Setting Range and Description	Minimum Unit	Factory Default	Change Limit
Fb.2.18	Automatic shift frequency	0~5.00Hz	0.01	1.00	
Fb.2.19	Automatic shift switching cycle	0.10~2.00Sec.	0.01	0.30	
Fb.2.20	Zero frequency torque holdup (DC bind-type brake preferred)	<p>0: Void</p> <p>1: Bind-type brake torque effective</p> <p>2: Position locking(PG feedback VC mode)</p> <p>3: Lock in the designated shutdown angle</p>	1	0	×
Fb.2.21	Position lock gain1(location gain)	00.10~10.00	0.01	1.00	
Fb.2.22	PG speed shaft propulsion distance per revolution	0.001~50.000mm	0.01	0.500	
Fb.2.23	Servo control function	<p>___X: Function selection</p> <p>0: Void</p> <p>1: Effective</p>	1	0000	×

Function Code	Name	Setting Range and Description	Minimum Unit	Factory Default	Change Limit
		2: External terminal selection (Function No.69) <b>__ X _: Action mode</b> 0: Common mode 1: Spindle orientation			
Fb.2.24	Position setting source in common mode	0: Reserved 1: Fin input 2: Digital setting 3: Analog inputAI1 4: MODBUS bus set value 1 5: MODBUS bus set value 2	1	1	
Fb.2.25	Position digital setting (lower)	0~65535	1	0	
Fb.2.26	Position digital setting (upper)	0~500	1	0	
Fb.2.27	Electronic gear (numerator)	0~65535	1	1000	
Fb.2.28	Electronic gear (denominator)	0~65535	1	1000	
Fb.2.29	Position command filtering time coefficient	1~1000.0ms	1	10	
Fb.2.30	Position gain 2	0.01~100.00	0.01	1.00	
Fb.2.31	Position gain selection	0: Gain 1 Effective 1: Gain 2 Effective 2: External terminal selection (Function No. 75) 3: Position deviation selection	1	0	
Fb.2.32	Position gain selected threshold value (Position deviation)	0~30000	1	10	
Fb.2.33	Speed feed-FWD gain	0.0~200.0 (%)	0.1	100.0	
Fb.2.34	Rotate speed regulating in common servo mode	0: Limit by the upper frequency 1: Minimax between the frequency set channel and position loop control	1	0	
Fb.2.35	—	—			
Fb.2.36	Spindle orientation mode	<b>___ X: Selection of reference signal for positioning zero point</b> 0: Z pulse positioning 1: Photoelectric switch positioning(Function No. 70) <b>__ X _: Command</b> 0: External terminal selection 1: Pulse command setting(Fin) <b>_ X _: Direction arrival</b> 0: Locate according to the order 1: Locate according to the minimum corner	1	0000	*
Fb.2.37	Spindle orientation frequency/speed	0.01~100.00Hz	0.01	5.00	
Fb.2.38	Spindle orientation angle 1	0~359.9	0.1	45.0	

Function Code	Name	Setting Range and Description	Minimum Unit	Factory Default	Change Limit
Fb.2.39	Spindle orientation angle 2	0~359.9	0.1	90.0	
Fb.2.40	Spindle orientation angle 3	0~359.9	0.1	135.0	
Fb.2.41	Spindle orientation angle 4	0~359.9	0.1	180.0	
Fb.2.42	Spindle orientation angle 5	0~359.9	0.1	225.0	
Fb.2.43	Spindle orientation angle 6	0~359.9	0.1	270.0	
Fb.2.44	Spindle orientation angle 7	0~359.9	0.1	315.0	
Fb.2.45	Spindle stop angle	0~359.9	0.1	0.0	
Fb.2.46	Spindle transmission ratio (detection spindle speed: Spindle Revolution )	0.010~50.000	0.001	1.000	×
Fb.2.47	Spindle orientation/Position reach error	0~500	1	5	
Fb.2.48	Servo torque compensation in low speed	0: null            1: valid 2: Multi-functional terminal input (function No.78)	1	0	
Fb.2.49	Servo torque compensate startup frequency in low speed	0.0 ~ 10.00Hz	0.01	2.00	

## 6.2.46 VIRTUAL INPUT AND OUTPUT

Function Code	Name	Setting Range and Description	Minimum Unit	Factory Default	Change Limit
FF.0.00	FF configuration parameter locking function (H)	<b>___ X: FF parameter modification forbidden</b> 0: Modification forbidden 1: Modification permitted <b>__ X_: Reserved</b> <b>_ X__: Reserved</b> <b>X ___: Initialization of FF parameter group</b> 0: Forbidden 1: Permitted	1	0000	
FF.0.01	Definition of virtual output node (SDO1)	0~71	1	0	
FF.0.02	Definition of virtual output node (SDO2)	0~71	1	0	
FF.0.03	Definition of virtual output node (SDO3)	0~71	1	0	
FF.0.04	Definition of virtual output node (SDO4)	0~71	1	0	
FF.0.05	Definition of virtual output node (SDO5)	0~71	1	0	
FF.0.06	Definition of virtual output node (SDO6)	0~71	1	0	
FF.0.07	Definition of virtual output node (SDO7)	0~71	1	0	
FF.0.08	Definition of virtual output node (SDO8)	0~71	1	0	

Function Code	Name	Setting Range and Description	Minimum Unit	Factory Default	Change Limit
FF.0.09	Definition of virtual input function (SDI1)	0~96	1	0	×
FF.0.10	Definition of virtual input function (SDI2)	0~96	1	0	×
FF.0.11	Definition of virtual input function (SDI3)	0~96	1	0	×
FF.0.12	Definition of virtual input function (SDI4)	0~96	1	0	×
FF.0.13	Definition of virtual input function (SDI5)	0~96	1	0	×
FF.0.14	Definition of virtual input function (SDI6)	0~96	1	0	×
FF.0.15	Definition of virtual input function (SDI7)	0~96	1	0	×
FF.0.16	Definition of virtual input function (SDI8)	0~96	1	0	×
FF.0.17	Virtual output- input connection polarity	<p>___ X: <b>SD01-SD11</b>  0: Homopolar connection  1: Antipolar connection</p> <p>__ X_: <b>SD02-SD12</b>  0: Homopolar connection  1: Antipolar connection</p> <p>_ X__: <b>SD03-SD13</b>  0: Homopolar connection  1: Antipolar connection</p> <p>X ___: <b>SD04-SD14</b>  0: Homopolar connection  1: Antipolar connection</p>	1	0000	×
FF.0.18	Virtual output- input connection polarity	<p>___ X: <b>SD05-SD15</b>  0: Homopolar connection  1: Antipolar connection</p> <p>__ X_: <b>SD06-SD16</b>  0: Homopolar connection  1: Antipolar connection</p> <p>_ X__: <b>SD07-SD17</b>  0: Homopolar connection  1: Antipolar connection</p> <p>X ___: <b>SD08-SD18</b>  0: Homopolar connection  1: Antipolar connection</p>	1	0000	×

## 6.2.47 PROTECTION FUNCTION CONFIGURATION PARAMETER

Function Code	Name	Setting Range and Description	Minimum Unit	Factory Default	Change Limit
FF.1.19	Protection action configuration 1 (H)	<p>___ X: <b>Operation under voltage protection</b> 0: No action                    1: Act</p> <p>__ X_: <b>Output grounding protection</b> 0: No action                    1: Act</p> <p>_ X__: <b>Input Voltage lack of phase protection</b> 0: No action</p> <p>1: Trip and stop</p> <p>2: Nonstop alarm</p> <p>X ___: <b>Output current phase shortage or unbalancing protection</b> 0: No action</p> <p>1: Trip and stop</p> <p>2: Nonstop alarm</p>	1	1111	
FF.1.20	Protection action configuration 2 (H)	<p>___ X: <b>Temperature sensor fault</b> 0: No action</p> <p>1: Trip and stop</p> <p>2: Nonstop alarm</p> <p>__ X_: <b>Inverter overheat alarm</b> 0: Closed                    1: Act</p> <p>_ X__: <b>Input voltage unbalancing protection (Void for single camera)</b> 0: No action</p> <p>1: Trip and stop</p> <p>2: Nonstop alarm</p> <p>X ___: <b>Motor over temperature protection</b> 0: No action</p> <p>1: Trip and stop</p> <p>2: Nonstop alarm</p>	1	1111	
FF.1.21	Protection action configuration 3 (H)	<p>___ X: <b>Relay action fault protection</b> 0: No action                    1: Act</p> <p>__ X_: <b>Internal data memory abnormality protection</b> 0: No action                    1: Act</p> <p>_ X__: <b>Inverter under voltage operation alarm</b> 0: Closed                    1: Act</p> <p>X ___: <b>Reserved</b></p>	1	0111	
FF.1.22	Protection action configuration 4 (H)	<p>___ X: <b>Drive protection action</b> 0: Closed                    1: Act</p> <p>__ X_: <b>Reserved</b></p> <p>_ X__: <b>A. B impulse anti-receive protection</b> 0: Closed                    1: Act</p>	1	0001	
FF.1.23	Protective action configuration 5 (H)	<p>___ X: <b>warning the message shielded</b> 0: Closed                    1: Act (no warning)</p> <p>__ X_: <b>Output supply power protection of phase sequence (reversed)LED</b> 0: Closed</p>	1	0000	

Function Code	Name	Setting Range and Description	Minimum Unit	Factory Default	Change Limit
		1: Trip out when phase sequence goes wrong 2: The warning of no shutdown when phase sequence goes wrong			
FF.1.24	Reserved	—	—	—	

### 6.2.48 CORRECTION PARAMETER

Function Code	Name	Setting Range and Description	Minimum Unit	Factory Default	Change Limit
FF.2.25	AI1 zero offset adjustment	-0.500~0.500V	0.001	0.0	
FF.2.26	AI1 gain correction	0.950~1.050	0.001	1.000	
FF.2.27	4mA offset adjustments for AI2	-0.500~0.500mA	0.001	0.0	
FF.2.28	AI2 gain correction	0.950~1.050	0.001	1.000	
FF.2.29	AI3 zero offset adjustment	-0.500~0.500V	0.001	0.0	
FF.2.30	AI3 gain correction	0.950~1.050	0.001	1.000	
FF.2.31	AO1 zero offset correction	-0.500~0.500V	0.001	0.0	
FF.2.32	AO1 gain correction	0.950~1.050	0.001	1.000	
FF.2.33	AO2 zero offset correction	-0.500~0.500V	0.001	0.0	
FF.2.34	AO2 gain correction	0.950~1.050	0.001	1.000	
FF.2.35	under voltage action level	320~450V	1	400	×
FF.2.36	Correction coefficient of DC side voltage detection value	0.950~1.050	0.001	1.000	

### 6.2.49 SPECIAL FUNCTIONAL PARAMETERS

Function Code	Name	Setting Range and Description	Minimum Unit	Factory Default	Change Limit
FF.3.37	Torque limit configuration (H)	<p>___ X: Constant torque area torque limitation</p> <p>0: Only limited by torque limiting parameter (including Revolution PID output limit)</p> <p>1: Also limited by acceleration and deceleration current level and maximum permitted current</p> <p>___ X_: Reserved</p> <p>_ X_: Constant power area torque limitation</p> <p>0: Treated the same as the constant torque area</p> <p>1: Simultaneously adjusted as per constant power algorithm</p>	1	0101	
FF.3.38	Current closed-loop proportional gain	0.10 ~ 10.00	0.01	1.00	
FF.3.39	Current closed-loop integration time constant	0.10 ~ 10.00 (Sec.)	0.01	1.00	
FF.3.40	Total leakage inductance compensation constant	0.10 ~ 10.00	0.01	1.00	

## 6.2.50 OTHER CONFIGURATION PARAMETERS

Function Code	Name	Setting Range and Description	Minimum Unit	Factory Default	Change Limit
FF.4.41	Cooling fan control	<p><b>___X: Soft start function (effective for model 4T0370 and below)</b> 0: No action      1: Act</p> <p><b>__X_: Air volume auto adjustment (effective for model 4T0370 and below)</b> 0: No action      1: Act</p> <p><b>_X_: Start time</b> 0: Start immediately after power-on 1: Start after running</p> <p><b>X___: Reserved</b></p>	1	0101	
FF.4.42	Operating panel control options	<p><b>___X: Panel REV/JOG key function selection</b> 0: REV (REV running key) 1: JOG (FWD jog key)</p> <p><b>__X_: Reserved</b></p> <p><b>_X_: Reserved</b></p> <p><b>X___: Panel control selection (except STOP key)</b> 0: Standard panel interface control (can be connected to monitoring panel via RS485) 1: RS485 port external panel control (standard panel, only for monitoring) 2: Multifunctional terminal switching (Function No. 40)</p>	1	0000	×
FF.4.43	Special function configuration	<p><b>___X: Motor parameter identification auto-start</b> 0: Forbidden      1: Permitted</p> <p><b>__X_: Voltage vector composition mode</b> 0: Three-phase composition 1: Two-phase composition</p> <p><b>_X_: Voltage small pulse shielding</b> 0: Void            1: Effective</p> <p><b>X___: SVC Revolution identification mode</b> 0: Current open-loop mode 1: Current closed-loop mode (Reserved)</p>	1	0001	
FF.4.44	Asynchronous motor parameter adaptive correction	<p><b>LED ___X: Stator resistance</b> 0: Forbidden      1: Permitted</p> <p><b>LED __X_: Total leakage inductance</b> 0: Forbidden      1: Permitted</p> <p><b>LED _X_: Rotor time constant</b> 0: Forbidden      1: Permitted</p> <p><b>LED X___: Torque increasing function</b> 0: Void            1~5: Effective</p>	1	0011	
FF.4.45	Random reference value	0~65535	1		R

## 6.2.51 HISTORICAL FAULT RECORDING

Function Code	Name	Setting Range and Description	Minimum Unit	Factory Default	Change Limit
dE.0.00	Last time fault recording	-	-	-	R/I
dE.0.01	Historical fault 1	-	-	-	R/I
dE.0.02	Historical fault 2	-	-	-	R/I
dE.0.03	Historical fault 3	-	-	-	R/I
dE.0.04	Historical fault 4	-	-	-	R/I
dE.0.05	Historical fault 5	-	-	-	R/I
dE.0.06	Historical fault 6	-	-	-	R/I
dE.0.07	Historical fault 7	-	-	-	R/I

## 6.2.52 OPERATION STATUS AT THE LAST FAULT

Function Code	Name	Setting Range and Description	Minimum Unit	Factory Default	Change Limit
dE.0.08	Operating frequency (rotor synchronous frequency)	-300.00~300.00Hz	0.01	0	R/I
dE.0.09	Output current	0.0~3000.0A	0.1	0	R/I
dE.0.10	Output voltage	0~1000V	1	0	R/I
dE.0.11	Detection motor revolution	0~30000rpm	1	0	R/I
dE.0.12	Voltage at the DC side	0~1000V	1	0	R/I
dE.0.13	Output torque	-300.0~ 300.0%	0.1%	0	R/I
dE.0.14	Target frequency	0.0~300.00Hz	0.01	0	R/I
dE.0.15	Equipment maximum temperature	0.0~150.0	0.1°C	0	R/I
dE.0.16	Command status	<b>___X:</b> 0: Stop command 1: Running command <b>__X_:</b> Reserved <b>_X__:</b> Reserved <b>XXXX:</b> Reserved	1	0000	R/I
dE.0.17	Inverter operation status	<b>___X: Operation mode</b> 0: V/F mode 1: Open-loop vector speed 2: Closed-loop vector speed 3: Open-loop torque control 4: Closed-loop torque control <b>__X_: Operation status</b> 0: Stop 1: Start acceleration 2: Stop deceleration 3: Decreasing frequency and deceleration 4: Steady operation <b>_X__: Electric/braking status</b>	1	0000	R/I



Function Code	Name	Setting Range and Description	Minimum Unit	Factory Default	Change Limit
		0: Electric operation 1: Power generation operation <b>X ___: Limit suppression</b> 0: No action 1: Over current suppression action 2: Overvoltage suppressor action 3: under voltage suppression action			
dE.0.18	Accumulative startup running time at the last fault	0~65535	1h	65535	R/I
dE.0.19	Startup running interval between the last two faults	0~65535	1h	65535	R/I
dE.0.20	Actual output frequency	-300.00~300.00Hz	0.01	0	R/I

### 6.2.53 BASIC STATUS PARAMETER

Function Code	Name	Setting Range and Description	Minimum Unit	Factory Default	Change Limit
d0.0.00	Output frequency and direction (rotor synchronous frequency)	-300.0Hz ~ 300.00Hz	0.01Hz		R
d0.0.01	Motor revolution and direction	-30000~30000rpm	1rpm		R
d0.0.02	Output current	0.0~ 6000.0A	0.1A		R
d0.0.03	Output torque	-300.0~300.0%	0.1%		R
d0.0.04	Output voltage	0~500V	1V		R
d0.0.05	Output power	-1000.0~1000.0KW	0.1KW		R
d0.0.06	Device body maximum temperature	0~150.0°C	0.1°C		R
d0.0.07	Voltage at DC side	0~1000V	1V		R
d0.0.08	Inverter running status	<b>___ X: Operation mode</b> 0: V/F mode 1: Open-loop vector speed 2: Closed-loop vector speed 3: Open-loop torque control 4: Closed-loop torque control 5: V/F separated control <b>__ X_: Operation status</b> 0: Stop 1: Start acceleration 2: Stop deceleration 3: Decreasing frequency and deceleration 4: Steady operation <b>_ X __: Electric/ braking status</b> 0: Electric operation 1: Power generation operation <b>X ___: Limit suppression</b> 0: No action 1: Over current suppression action	1		R

Function Code	Name	Setting Range and Description	Minimum Unit	Factory Default	Change Limit
		2: Overvoltage suppressor action 3: under voltage suppression action			
d0.0.09	Frequency setting channel command ( frequency)	-300.00Hz ~ 300.00Hz	0.01Hz		R
d0.0.10	Revolution Setting channel command (Revolution)	-30000~30000rpm	1rpm		R
d0.0.11	Torque command value (set input)	-300.0~300.0%	0.1%		R
d0.0.12	Target operating frequency (integrator input)	-300.0Hz ~ 300.00Hz	0.01Hz		R
d0.0.13	Target running revolution (integrator input)	-30000~30000rpm	1rpm		
d0.0.14	Speed adjuster deviation	-3200~3200rpm	1rpm		
d0.0.15	Speed adjuster output	-300.0~300.0(%)	0.1%		
d0.0.16	Process PID setting	-100.0~100.0(%)	0.1%		
d0.0.17	Process PID feedback	-100.0~100.0(%)	0.1%		
d0.0.18	Process PID deviation	-100.0~100.0(%)	0.1%		
d0.0.19	Process PID output	-100.0~100.0(%)	0.1%		
d0.0.20	Compensation PID setting	-100.0~100.0(%)	0.1%		
d0.0.21	Compensation PID feedback	-100.0~100.0(%)	0.1%		
d0.0.22	Compensation PID deviation	-100.0~100.0(%)	0.1%		
d0.0.23	Compensation PID output	-100.0~100.0(%)	0.1%		
d0.0.24	Accumulative running time (H)	0~65535h	1h		
d0.0.25	Accumulative power-on time (H)	0~65535h	1h		
d0.0.26	Power-on (hh.mm.s) cycling timing	00.00.0~23.59.9	1		
d0.0.27	Kilowatt-hour counter (low)	0~1000.0KWh	0.1KWh		
d0.0.28	Kilowatt-hour counter (high)	0~60000KKWh	1KKWh		
d0.0.29	Megawatt hour counter	0~60000MW	1 MW		

## 6.2.54 AUXILIARY STATUS PARAMETER

Function Code	Name	Setting Range and Description	Minimum Unit	Factory Default	Change Limit
d0.1.30	Frequency setting source 1 set value	0.0~300.00Hz	0.01Hz	-	R
d0.1.31	Frequency setting source 2 set value	0.0~300.00Hz	0.01Hz	-	R
d0.1.32	Frequency/revolution integrator output	-300.0Hz~300.00Hz	0.01Hz	-	R
d0.1.33	Stator synchronous frequency	-300.0Hz~300.00Hz	0.01Hz	-	R
d0.1.34	Actually measured revolution value	-30000~30000rpm	1rpm	-	R
d0.1.35	Inverter overload integrator value	0 ~ 1020	1	-	
d0.1.36	Process PID set variable (physical quantity)	0.01~60000	0.01	-	R
d0.1.37	Process PID feedback variable (physical quantity)	0.01~60000	0.01	-	R
d0.1.38	Compensation PID set variable (physical quantity)	0.01~60000	0.01	-	R
d0.1.39	Compensation PID feedback variable (physical quantity)	0.01~60000	0.01	-	R
d0.1.40	Torque current	-3000.0~3000.0A	0.1A	-	R
d0.1.41	Excitation current	0.0~3000.0A	0.1A	-	R
d0.1.42	Device body temperature detection 1	0~150.0°C	0.1°C	-	R
d0.1.43	Device body temperature detection 2	0~150.0°C	0.1°C	-	R
d0.1.44	Device body temperature detection 3	0~150.0°C	0.1°C	-	R
d0.1.45	Motor temperature	0~250.0°C	0.1°C	-	R

## 6.2.55 MODBUS FIELD BUS STATUS PARAMETER (Standard Expansion Card)

Function Code	Name	Setting Range and Description	Minimum Unit	Factory Default	Change Limit
d0.2.46	Bus communication set value 1	-10000~10000	1		R
d0.2.47	Bus communication set value 2	-30000~30000	1		R
d0.2.48	Bus command word 1 (HEX)	0~0FFFFH	1		R
d0.2.49	Bus command word 2 (HEX)	0~0FFFFH	1		R
d0.2.50	Bus status word 1 (HEX)	0~0FFFFH	1		R
d0.2.51	Bus status word 2 (HEX)	0~0FFFFH	1		R
d0.2.52	Total quantity of bus information	0~65535	1		R
d0.2.53	Number of bus CRC check errors	0~65535	1		R
d0.2.54	Number of error data accepted by bus	0~65535	1		R
d0.2.55	Number of effective data of bus	0~65535	1		R

### 6.2.56 TERMINAL STATUS AND VARIABLE

Function Code	Name	Setting Range and Description	Minimum Unit	Factory Default	Change Limit
d1.0.00	Terminal input (DI1~DI10)	Segment marker	-	-	R
d1.0.01	Terminal input (EDI1~EDI10)	Segment marker	-	-	R
d1.0.02	Pulse input (Fin)	0.0~100.00KHz	0.01		R
d1.0.03	Analog input AI1	0.00~10.00V	0.01		R
d1.0.04	Analog input AI2	0.00~20.00mA	0.01		R
d1.0.05	Analog input AI3	-10.00~10.00V	0.01		R
d1.0.06	Digital signal output (DO1~DO4, EDO1~ EDO6)	Segment marker	-	-	R
d1.0.07	Relay contact output (RO1~RO4, ERO1~ERO6)	Segment marker	-	-	R
d1.0.08	Frequency output Fout (indicating the duty ratio in the case of PWM signal output)	0.0~100.0KHz	0.01		R
d1.0.09	Analog output AO1	0.00~10.00V	0.01		R
d1.0.10	Analog output AO2	0.00~10.00V	0.01		R



Figure 6-1 Terminal effective sketch



➤ As shown in Figure 6-1, DI2, DI3, DI7, DI9 terminal input is in effective status, and other terminals are at void status.

### 6.2.57 COUNTER TIMER VALUE

Function Code	Name	Setting Range and Description	Minimum Unit	Factory Default	Change Limit
d1.1.11	Counter 1 current value	0~65535	1		R
d1.1.12	Counter 2 current value	0~65535	1		R
d1.1.13	Timer 1 current value	0~65535	1		R
d1.1.14	Timer 2 current value	0~65535	1		R
d1.1.15	Timer 3 current value	0~65535	1		R

## 6.2.58 SPINDLE CONTROL AND SCALE POSITIONING STATUS PARAMETER

Function Code	Name	Setting Range and Description	Minimum Unit	Factory Default	Change Limit
d1.2.16	Spindle (PG installation shaft) position angle	0~359.9			R
d1.2.17	Spindle (PG installation shaft ) traveling circle number	0~65535			R
d1.2.18	Accumulative number of position pulse (low)	0~65535			R
d1.2.19	Accumulative number of position pulse (middle)	0~65535			R
d1.2.20	Progressive distance	0.0~5000.0mm			R
d1.2.21	Set position pulse( low)	0~65535			R
d1.2.22	Set position pulse(middle)	0~65535			R
d1.2.23	Set position pulse(high)	0~65535			R

## 6.2.59 EQUIPMENT INFORMATION

Function Code	Name	Setting Range and Description	Minimum Unit	Factory Default	Change Limit
d1.4.40	Expansion module connection information	<b>___X: Reserved</b> <b>__X_: Standard expansion board</b> 0: Not connected 1: Connected <b>_X_: Functional expansion board 1</b> 0: Not connected 1~F: Connected (the value stands for the type of expansion board) <b>X___: Functional expansion board 2</b> 0: Not connected 1~F: Connected (the value stands for the type of expansion board)	1	—	R
d1.4.41	Total quantity of panel communication information	0~65535	1	—	R
d1.4.42	Number of panel communication CRC check errors + number of errors accepted	0~65535	1	—	R
d1.4.43	Number of effective data of panel communication	0~65535	1	—	R
d1.4.44	Equipment model	Reserved	1	—	R
d1.4.45	Equipment capacity	0.1~1000.0KW	0.1KW	—	R
d1.4.46	Motherboard program version (H)	6000~6999	1	—	R
d1.4.47	Reserved		1	—	R
d1.4.48	Motherboard check date(H)	2009~2100	1	—	R
d1.4.49	Motherboard check date(H)	0101~1231	1	—	R
d1.4.50	Motherboard check serial number	0 ~ 50000	1	—	R

**Table 1: Comparison Table of Multifunctional Input Terminal (DI/EDI/SDI) Functions**

S/N	Function	S/N	Function
0	No function	1	Multi-speed control 1
2	Multi-speed control 2	3	Multi-speed control 3
4	Multi-speed control 4	5	FWD jog
6	REV jog	7	Forward (FWD) running command terminal
8	Reverse (REV)running command terminal	9	Acceleration and deceleration time selection 1
10	Acceleration and deceleration time selection 2	11	Running command switching
12	Frequency command switching	13	Fault resetting input (RESET)
14	Emergency stop (EMS)	15	Frequency or Process PID set value ascending (UP)
16	Frequency or Process PID set value descending (DW)	17	UP/DW set frequency clear
18	External equipment fault	19	Three-line running control
20	Stop DC braking command	21	Acceleration and deceleration forbidden
22	Process PID effective	23	Simple PLC multi-stage running effective
24	Swing frequency running effective	25	Compensation PID effective
26	Simple PLC multi-stage running status (when stopping ) resetting	27	Swing frequency status resetting (effective when stopping)
28	Multi-stage process PID giving terminal 1	29	Multi-stage Process PID giving terminal 2
30	Multi-stage process PID giving terminal 3	31	Process PID setting selection (switching)
32	Process PID feedback selection (switching)	33	Process PID sleep activation
34	Torque/speed control mode switching	35	Minimum torque limiting set value selection
36	Maximum torque limiting set value selection	37	Overvoltage suppression Input
38	Load dynamic balancing effective	39	Reserved
40	RS485 external/Standard operation panel control switching	41	Load motor switching
42	Start permission	43	Running permitted
44	Counter 1 clock terminal	45	Counter 2 clock terminal
46	Counter 1 trigger signal	47	Counter 2 trigger signal
48	Counter 1 resetting terminal	49	Counter 2 resetting terminal
50	Counter 1 gated signal	51	Counter 2 gated signal
52	Timer 1 trigger signal	53	Timer 2 trigger signal
54	Timer 3 trigger signal	55	Timer 1 resetting
56	Timer 2 resetting	57	Timer 3 resetting
58	Timer 1 gated signal	59	Timer 2 gated signal
60	Timer 3 gated signal	61	Single pulse accumulative length value resetting
62	Motor temperature detection contact input	63	Compensation PID parameter selection1
64	Compensation PID parameter selection 2	65	Magnetic flux brake
66	Position pulse counting (PG pulse counting accumulation) resetting	67	Automatic shifting (Spindle shifting jog running)
68	Servo pulse command direction (Fin)	69	Servo control effective
70	Spindle positioning origin photoelectric signal input	71	Spindle origin homing

S/N	Function	S/N	Function
72	Spindle positioning selection 1	73	Spindle positioning selection 2
74	Spindle positioning selection 3	75	Position gain selection
76	Reserved	77	Servo command pulse value clear
78	Servo torque compensation at low speed	79~96	Reserved
97	0.1Hz~100.00KHz pulse input(DI9/Fin Effective)	98	Pulse input(DI9/Fin Effective)

**Table 2: Comparison Table of Multifunctional Output Terminal (DO/EDO/SDO) Variables**

S/N	Function	S/N	Function
0	No definition	1	Inverter running ready (normal voltage, no emergency stop input)
2	Inverter is running	3	Equipment normal (fault-free running)
4	Equipment fault (trip)	5	Equipment alarm
6	Equipment fault or alarm	7	REV running
8	Running command input (irrelevant with start or running signal)	9	Running at zero speed
10	Speed not at zero	11	Inverter under voltage stop
12	Terminal control effective	13	In the process of acceleration running
14	In the process of deceleration running	15	Braking power generation running status
16	Determined by standard MODBUS Fieldbus	17	Determined by Extended communication module
18	Reserved	19	Completion of current stage of multi-stage running (0.5s pulse )
20	Multi-stage running completed (0.5s pulse )	21	Multi-stage running completed (continuous level output)
22	Multi-stage running cycle completed (0.5s pulse )	23	Swing frequency upper and lower limit
24	Encoder direction positive (A pulse surpassing B pulse )	25	Encoder direction negative (A behind B)
26	Monitor 1 input variable below the lower limit (Void when above the upper limit)	27	Monitor 1 input variable above the upper limit(void when below the lower limit)
28	Monitor 1 input variable between the upper limit and the lower limit	29	Monitor 2 variable below the lower limit (void when above the upper limit)
30	Monitor 2 input variable above the upper limit(void when below the lower limit)	31	Monitor 2 input variable between the upper limit and the lower limit
32	Monitor 3 input variable below the lower limit(void when above the upper limit)	33	Monitor 3 input variable above the upper limit (void when below the lower limit)
34	Monitor 3 input variable between the upper limit and the lower limit	35	Position reached (Servo or spindle control)
36	Analog input AI1 wire breakage detection effective	37	Analog input AI2 wire breakage detection effective
38	Analog input AI3 wire breakage detection effective	39	Reserved

S/N	Function	S/N	Function
40	Counter 1 output signal 1	41	Counter 1 output signal 2
42	Counter 2 output model 1	43	Counter 2 output signal 2
44	Timer 1 output signal 1	45	Timer 1 output signal 2
46	Timer 2 output signal 1	47	Timer 2 output signal 2
48	Timer 3 output signal 1	49	Timer 3 output signal 2
50	Extension modules retained	51	Extension modules retained
52	Extension modules retained	53	Extension modules retained
54	Extension modules retained	55	DI1 terminal status effective
56	DI2 terminal status effective	57	DI3 terminal status effective
58	DI4 terminal status effective	59	DI5 terminal status effective
60	DI6 terminal status effective	61	DI7 terminal status effective
62	DI8 terminal status effective	63	Terminal as frequency output (only applicable to DO3/FO terminal)
64	SDO1 LDI	65	SDO2 LDI
66	SDO1 $\odot$ SDO2 AND	67	SDO3 $\odot$ SDO4 AND
68	SDO5 $\odot$ SDO6 AND	69	SDO3 $\oplus$ SDO4 OR
70	SDO5 $\oplus$ SDO6 OR	71	SDO7 $\oplus$ SDO8 OR



➤ Direction will not be considered for comparison of monitor variables

**Table 3: Comparison Table of Monitor Variables**

S/N	Monitoring Parameter Variable	100% full-scale output
0	Output frequency (rotor synchronous frequency)	Upper limiting frequency
1	Motor Revolution	Upper limiting frequency*60/pairs of motor poles
2	Output current	250%*Inverter rated current
3	Output torque	300% rated torque
4	Output voltage	Motor rated voltage (reference voltage in V/F mode)
5	Output power	2* motor rated power
6	Maximum temperature of the equipment	150.0°C
7	Voltage at the DC side	1000V (single phase 500V)
8	Motor temperature/ PTC resistance	500.0°C / 5000Ω
9	Frequency setting channel set value	Upper limiting frequency
10	Speed command	Upper limiting frequency*60/pairs of motor poles
11	Torque command	300% rated torque
12	Target operating frequency	Upper limiting frequency
13	Reserved	—
14	Speed adjuster deviation	Upper limiting frequency*60/pairs of motor poles



S/N	Monitoring Parameter Variable	100% full-scale output
15	Speed adjuster output	300.0%
16	Process PID setting	100.0%
17	Process PID feedback	100.0%
18	Process PID deviation value	200.0%
19	Process PID output	100.0%
20	Compensation PID setting	100.0%
21	Compensation PID feedback	100.0%
22	Compensation PID deviation	200.0%
23	Compensation PID output	100.0%
24	AI1 input (0.00~10.00)	10.00 V
25	AI2 input (0.00~20.00)	20.00mA
26	AI3 input (-10.00~10.00)	10.00V
27	Fin input	Maximum input frequency
28	Current liner speed (Fin calculation)	Maximum permitted liner speed
29	Accumulative counted length ( liner speed accumulation)	Maximum counted length
30	Counter 1 value	Counter 1 set value 2
31	Counter 2 value	Counter 2 set value 2
32	Timer 1 value	Timer 1 timing cycle
33	Timer 2 value	Timer 2 timing cycle
34	Timer 3 value	Timer 3 timing cycle
35	Built-in Fieldbus set value 1	10000
36	Extended communication module set value 1	10000
37	Built-in Fieldbus set value 2	30000
38	Extended communication module set value 2	30000
39~44	Reserve	
45	Fixed output (current or voltage)	20.00mA (10.00V)

## 7. DESCRIPTION OF SPECIFIC FUNCTIONS

Remark: Unless otherwise especially instructed, the status of terminals will be defined under positive logic conditions (“ON” terminals effective, and “OFF” terminals void).

### 7.1 SYSTEM MANAGEMENT (GROUP F0.0)

Group **F0.0** parameters are especially used to define system control parameters, e.g. locking, initializing, motor type and control mode as well as display of monitoring parameters, etc.

<b>F0.0.00 Macro parameters</b>	<b>Setting range: 0000~2006</b>	<b>Factory default: 0000</b>
---------------------------------	---------------------------------	------------------------------

Macro parameters include application macro, system macro and special macro; The application macro allows for conveniently setting and curing multiple common parameters and simplifying parameter setting for general applications; the system macro allows for conveniently switching equipment’s work mode and automatically defining partial parameters; The special macro allows for internal integration and settings for special functions or parameters with one key according to typical industrial applications.

Macro parameters are not influenced by the initializing parameter **F0.0.07** and partial macro-related parameters are locked at specific value or within specific range.

#### \_\_\_ X : Application macro

##### 0: Void

Customized settings, all parameters can be customized without being influenced by the application macro parameters.

##### 1: Digital setting of keypad control

Refer to Figure 7-1 for the application wiring diagram, and refer to Table 7-1 for macro- related parameters.

##### 2: Shuttle setting keypad control

Refer to Figure 7-1 for the application wiring diagram, and refer to Table 7-1 for macro- related parameters.

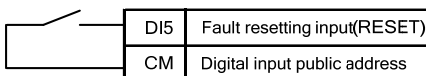

Figure 7-1 Wiring diagram for panel operation digital/shuttle setting

##### 3: 2 wire Control 1/A1 setting

Refer to Figure 7-2-A for the application wiring diagram, and refer to Table 7-1 for macro- related parameters.

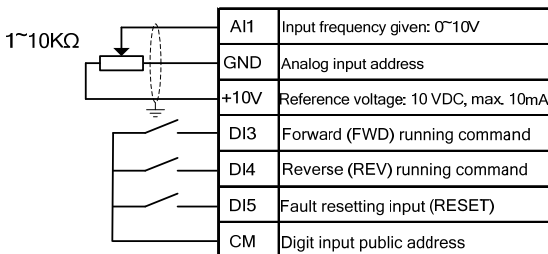

Figure 7-2-A 2 wire control 1/A1 setting wiring diagram

#### 4: 2 wire Control 2/AI1 setting

Refer to Figure 7-2-B for the application wiring diagram, and refer to Table 7-1 for macro- related parameters.

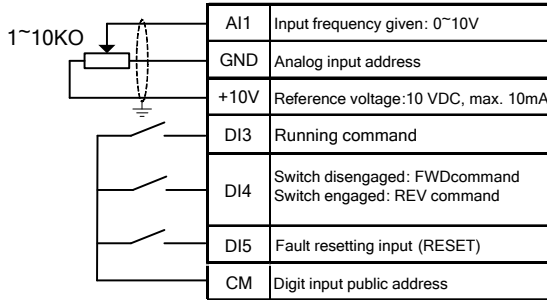

Figure 7-2-B 2 wire control 2/AI1 setting wiring diagram

#### 5: 3 wire control 1/AI1 setting

Refer to Figure 7-3 for the application wiring diagram, and refer to Table 7-1 for macro- related parameters.

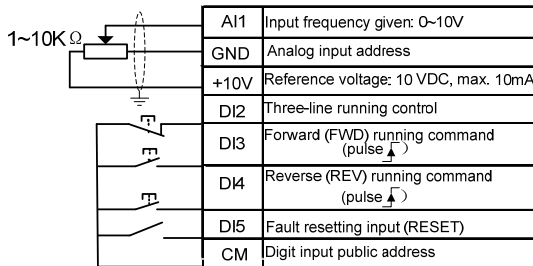

Figure 7-3 3 wire control 1/AI1 setting wiring diagram

Table 7-1: Table Application Macro Association Self-Setting Parameters

Parameters	Application Macro 1	Application Macro 2	Application Macro 3	Application Macro 4	Application Macro 5	Remarks
F0.1.15	0	0	0	0	0	Locked
F0.1.16	0	0	0	0	0	Locked
F0.1.18	1.00	1.00	1.00	1.00	1.00	Locked
F0.2.25	2 (0~2)	3	9	9	9	Locked
F0.3.33	0	0	1	1	1	Locked
F0.3.35	—	—	0	1	2	Locked
F0.4.37	0	0	0	0	0	Locked
F0.4.38	0	0	0	0	0	Locked
F3.0.01	—	—	—	—	19	Locked
F3.0.02	—	—	7	7	7	Locked
F3.0.03	—	—	8	8	8	Locked
F3.0.04	13	13	13	13	13	Locked

Parameters	Application Macro 1	Application Macro 2	Application Macro 3	Application Macro 4	Application Macro 5	Remarks
F6.1.15	0	0	0	0	0	Relocatable
F6.2.46	0	0	0	0	0	Relocatable
F7.0.00	0	0	0	0	0	Relocatable
F8.0.00	0	0	0	0	0	Relocatable
F9.0.00	0	0	0	0	0	Relocatable
FA.2.25	0	0	0	0	0	Relocatable

## 6: Machine tool spindle drive/AI1 setting

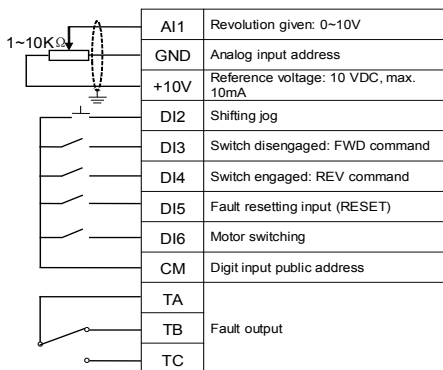

Figure 7-4 Machine tool spindle driving macro AI1 setting wiring diagram

### Associated macro parameters

Associated parameters	F0.0.09	F0.2.25	F0.3.33	F0.3.35	F0.4.37	F0.4.38	F3.0.01	F3.0.02	F3.0.03
Macro set value	0000	9	1	0	0	0	67	7	8
Value locking	N	Y	Y	Y	Y	Y	Y	Y	Y
Associated parameters	F3.0.04	F3.0.05	F3.1.21	F5.3.32	F6.1.15	F6.2.46	F7.0.00	F8.0.00	F8.3.39
Macro set value	13	41	4	1	0	0	0	0	0
Value locking	Y	Y	Y	Y	N	N	N	N	N

### X \_\_ : System macro (0~F)

The system macro cannot be modified unless correct modification password [F0.0.02] is set. Refer to the instructions of **F0.0.02** parameter for details. Modification of system macro will automatically lead to initialization of all functional parameters (Group **FF** parameters will not be initialized unless **FF.0.00** allows for initialization).

#### 0: Standard operation mode

##### 1: Steady load operation

Applicable to steady load (e.g. fan and pump load). In this mode, the load capacity of the equipment will be automatically increased by one power grade, and the initialization value of motor parameters will be also

automatically increased by one function grade.

<b>F0.0.01 Parameter display and modification (H)</b>	<b>Setting range: 0000~9014</b>	<b>Factory default: 0001</b>
---	---------------------------------	------------------------------

\_\_\_ X : **Parameter display mode**

#### 0: Display all parameters

#### 1: Display effective configuration parameters

To automatically hide the parameters irrelevant with current command or hardware according to different parameter setting commands or different current hardware configuration (e.g. various expansion boards), so as to simplify field commissioning.



- F0.0.00 and F0.0.01 are not limited by the parameter display mode, and will not be concealed in any display mode. The panel displaying parameters concealed due to parameter display mode will not influence the access to the concealed parameter via communication port.

#### 2: Display parameters different from factory default

#### 3: Display modified and stored parameters after power-on this time

#### 4: Display modified and un-stored parameters after power-on this time

\_\_ X \_ : **Parameter modification mode**

The macro parameter **F0.0.00** is also limited by this function.

#### 0: Effective and permanently stored after modification

Parameters modified will be immediately stored in the memory and permanent saved, and will not lose after power-off.

#### 1: Effective after modification but not stored, and getting lost after power-off

Parameters modified are effective but are not saved in the memory. And parameters modified will automatically restore to the values saved in the memory after completion of relevant operation or power-off. This function is used for tentative modification of undetermined parameters for field commissioning; After commissioning, all modified and unsaved parameters can be displayed for view separately (when the unit of this parameter is set to 4), and batch recovery or batch storage will be conducted (when the kilobit of this parameter is set to 2 or 5).

X \_\_\_ : **Batch recovery or batch storage of parameters**

The macro parameter **F0.0.00** is not subject to the influence of this function.

#### 2: Abandon modifying all unsaved parameters (restoring to original value)

All unsaved parameters will be rapidly restored to the values stored in the memory with one key.

This function can only be used when the device is stopped. If this function is activated when the device is running, the inverter will send alarm **aL.058** and give up operation.

#### 5: Batch storing all modified and unsaved parameters

All modified and unsaved parameters will be saved in the memory.

#### 9: Resume all parameters to initial values at the last power-on

To restore all parameters to the initial values at the last power-on. Even after initialization, all parameters can be restored to the preliminary power-on values with this function. This function is used to make correction during field commissioning when the system works abnormally because no one knows which parameter is

modified incorrectly at the current power-on.

This function can only be used when the device is stopped. If this function is activated when the device is running, the inverter will send alarm **aL.059** and give up operation.

<b>F0.0.02 Macro-call parameter modification password</b>	<b>Setting range: 0~65535</b>	<b>Factory default: 0</b>
---	-------------------------------	---------------------------

For modifying the system macro setting (kilobit) of the macro parameter **F0.0.00**, the modification password 1580 must be entered. This password will automatically disappear after 30 seconds. The macro parameter cannot be modified once within 30 seconds upon input of the password. If it is intended to make modification once again, the password should be entered again.

<b>F0.0.04 LCD display setting (H)</b>	<b>Setting range: 0000~0037</b>	<b>Factory default: 0023</b>
--	---------------------------------	------------------------------

This function is only effective for the operating panel equipped with LCD.

**\_\_ X \_\_: Normal display mode**

**0: Steady mode**

**1: Single parameter display**

The LCD panel will only display the status parameters set for **F0.0.12** in the normal monitoring mode.

**2: Dual parameter display**

The LCD panel will display the status parameters set for **F0.0.12** and **F0.0.13** in the normal monitoring mode.

**3: Three parameter display**

The LCD panel will display the status parameters set for **F0.0.12**, **F0.0.13** and **F0.0.14** in the normal monitoring mode.

<b>F0.0.05 Parameter locking (H)</b>	<b>Setting range: 0000~0012</b>	<b>Factory default: 0000</b>
<b>F0.0.06 Parameter locking password</b>	<b>Setting range: 0~65535</b>	<b>Factory default: 0</b>

After the parameter locking is effective, during modification of the locked parameter, **LED** panel will display “--”; **LCD** panel will prompt “password locked and modification forbidden”. This function is used to forbid modification of functional parameters by unauthorized personnel.

The password setting will take effect if **OK** key is pressed down within 30 seconds. If no confirmation (**OK** key) is conducted beyond 30 seconds or any other key is pressed down within 30 seconds, the password setting will be given up. The sketch of locking operation is as below:

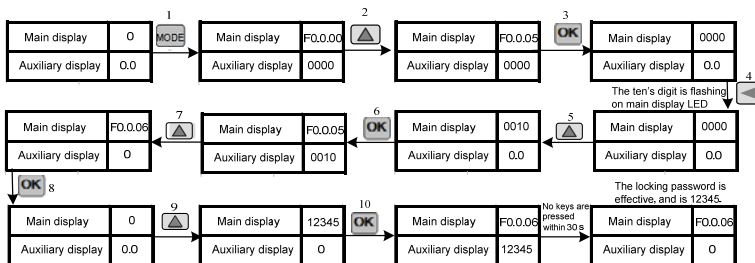

Figure 7-5 Parameter locking flow

Enter preset password and then press **OK**, and then the parameter locking status will be relieved. The sketch of unlocking operation is as below:

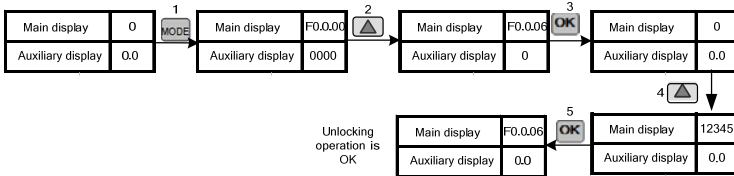

Figure 7-6 Parameter unlocking flow

<b>F0.0.07 Parameter initialization</b>	<b>Setting range: 0~8</b>	<b>Factory default: 0</b>
---	---------------------------	---------------------------

When the macro parameter **F0.0.00** is effective, the self-setting parameter relevant with the macro will not be influenced by the initialization. Refer to the function description of **F0.0.00**.

**FF** group parameters will not be initialized by this parameter until the kilobit of **FF.0.00** parameter is set to 1.

<b>F0.0.08 Parameter copying (H)</b>	<b>Setting range: 0000~0013</b>	<b>Factory default: 0000</b>
--------------------------------------	---------------------------------	------------------------------

\_\_\_ X : Upload and download

**0: No action**

**1: Parameter upload**

The inverter will upload parameter values in the control board memory to the panel memory.

**2: Parameter download**

The parameter values in the panel memory will be downloaded to the control board memory.

**3: Parameter download (except for motor parameters/F2 Group)**

The parameter values in the panel memory will be downloaded to the control board memory (motor parameters will not be downloaded).

Note: when the inverter is running, the action of upload and download is forbidden, and the setting for this parameter will not take effect.

During parameter upload and download, all keys except for **STOP** key on the panel are temporarily locked. Press **STOP** key to forcibly terminate upload and download; when the unload operation is forcibly terminated, the parameters uploaded will be stored in the panel memory, and the parameters not unloaded will be kept unchanged; when the download operation is forcibly terminated, the inverter will give up all parameters already downloaded into the control board memory, and automatically restore to the values before download.

The alarm signal relevant with this parameter is as below:

**aL.071** – Parameter unload failed. Uploaded parameters will be saved in the panel memory, and parameters not unloaded will be kept unchanged.

**aL.072** – Uploaded parameter storage failed. The panel memory is damaged or the memory is unavailable.

**aL.074** – Parameter download failed. Terminate the parameter download process, and all parameters downloaded will be automatically restored to the values before download.

**aL.075** – The board memory parameters are not consistent with the frequency inverter parameters in terms of the version.

**aL.076** – There are no effective parameters in the board memory.

**aL.077** – Some set values among the panel parameters are out of the allowable range. Terminate the parameter download process, and all parameters downloaded will be automatically restored to the values before download.

<b>F0.0.09 Selection of motor type and control mode (H)</b>	<b>Setting range: 0000~3131</b>	<b>Factory default: 0000</b>
---	---------------------------------	------------------------------

\_\_\_X/\_X\_\_\_ : Motor type selection

**0: Common motor**

**1: Asynchronous servo motor dedicated for the spindle**

Closed-loop vector control mode must be adopted, and specified motor should be used.

\_\_X/\_X\_\_\_ : Control Mode

**0: SVC (open-loop vector control) mode**

The vector control operation mode without the speed sensor features low frequency, high torque, steady speed and high precision. It can precisely control the motor's speed and torque, and is often used in the occasion in which **V/F** control mode cannot meet the requirements of high-performance universal variable speed drive.

**1: VC (closed-loop vector control) mode**

The vector control operation mode with the speed sensor is applicable to the occasion in which the torque response is faster and the control precision of torque and speed is higher. It enables for certain precision of position control so as to achieve control over simple servo positioning in the process of dragging the asynchronous motor. When dragging the synchronous motor, high precision of position service control (optional function) can be achieved.

**2: V/F control**

It refers to the constant control voltage/frequency ratio. It can be used to the occasion in which the performance is not required to be very high, and is also applicable to the occasion in which single inverter drives several motors.

**3: V/F separated control**

It is used for special application occasions, and is also applicable to V/F separated control for torque motors. In this mode, the output voltage and output frequency of the inverter have no connection with each other, and are set separately by users.

In the case of V/F separated control, F0.0.25 is forced set to the frequency preset channel, and F0.2.26 is forcedly set to the voltage giving channel.

Note: This control mode cannot be used for common asynchronous motors and synchronous motors. The equipment may be damaged if this mode is mistakenly set.

<b>F0.0.11 Keypad operation (H)</b>	<b>Setting range: 0000~0224</b>	<b>Factory default: 0000</b>
-------------------------------------	---------------------------------	------------------------------

\_\_\_X : Locking of panel keys

After the key locking function is set with this function, the locking will not take effect until **ESC** key is pressed to back to the normal control mode. For details, please refer to **5.2 Basic Functions and Operating Methods of the Panel**.

**0: Not locked**

All keys are effective on the operating panel.

**1: All keys except for UP/DW (shuttle), STOP and RUN are locked.**

Only **UP/DW** (shuttle), **STOP** and **RUN** keys on the operating panel are effective.



**2: All keys except STOP and RUN are locked.**

Only the **STOP** and **RUN** keys on the operating panel are effective.

**3: All keys except STOP are locked.**

Only the **STOP** key on the operating panel is effective.

**4: Locking all keys**

All keys are void on the operating panel.

**\_ \_ X \_ : STOP button function****0: The modes other than the panel control are void.**

Only when the running command channel is the operating panel is it effective to press down the **STOP** key.

**1: Press STOP key in any control mode for deceleration stop.**

No matter the running command preset channel is the operating panel, external terminals or the communication port, when **STOP** key is pressed, the inverter will control the motor to achieve deceleration stop according to the current effective deceleration time. The priority of this stop mode is higher than that of parameter **F0.4.38**.

**2: Press STOP key in any control mode for free stop.**

No matter the running command preset channel is the operating panel, external terminals or the communication port, when **STOP** key is pressed, the inverter will stop output, and the motor stop in free sliding mode. The priority of this stop mode is higher than that of parameter **F0.4.38**.

**\_ X \_ \_ : Function of PANEL/REMOTE keys**

When the functional setting of **PANEL/REMOTE** keys is effective, and in the normal monitoring mode, the **PANEL/REMOTE** keys can be used to switch the running command channel. The switching status is not saved, and will get lost after power-off. The running command channel for the inverter is still the operating panel after power-on once again.

If **PANEL/REMOTE** keys are used to circularly switch to desired running command channel, it is required to press "**OK**" key for confirmation within 5s. Otherwise, it will not get effective.

The switching sequence of the running command channel: Operating panel running command channel (**PANEL/REMOTE** light on) → external terminal operating running command channel (**PANEL/REMOTE** light off) → communication port running command channel (**PANEL/REMOTE** light off) → operating panel running command channel (**PANEL/REMOTE** light on).

**0: Void**

The running command channel cannot be switched with **PANEL/REMOTE** key.

**1: Effective at stop**

**PANEL/REMOTE** key is effective at the stop status, but it is void to switch the running command channel with this key when the device is running.

**2: Continuous effective**

**PANEL/REMOTE** keys can be used to switch the running command channel both at the stop and running status.



- The command channel switching at the running status of the inverter should be used carefully. Be sure the safety before operation. If the running command (FWD/REV/JOG) after switching is inconsistent with that before switching, the inverter will change its current running status (stop, run or REV), which may cause accident.

<b>F0.0.12 Principal monitoring parameter (H)</b>	<b>Setting range: d0.00~d0.55 / d1.00~d1.55</b>	<b>Factory default: d0.00</b>
<b>F0.0.13 Auxiliary monitoring parameter 1 (H)</b>	<b>Setting range: d0.00~d0.55 / d1.00~d1.55</b>	<b>Factory default: d0.02</b>
<b>F0.0.14 Auxiliary monitoring parameter 2 (H)</b>	<b>Setting range: d0.00~d0.55 / d1.00~d1.55</b>	<b>Factory default: d0.04</b>

This group of parameters is used to determine display contents on the operating panel at the status monitoring mode, and bitwise operation must be followed for setting.

**The Principal monitoring parameter** is used to determine display contents on the main display column of the **LED** panel, or the first display parameter on the **LCD** panel (signal parameter display).

**The auxiliary monitoring parameter 1** is used to determine display contents on the auxiliary display column of the **LED** panel, or the second display parameter on the **LCD** panel (dual parameter display) when the inverter is running.

**The auxiliary monitoring parameter 2** is used to determine display contents on the auxiliary display column of the **LED** panel, or the third display parameter on the **LCD** panel (three parameter display) when the inverter is stopped.

The corresponding physical quantity of the display data can be referred to the status monitoring parameter table. When the inverter is conducting detection of motor parameters, the auxiliary display will display the value of the current output current, which is not restricted by the parameter **F0.0.13**.

## 7.2 RUNNING COMMAND SELECTION (GROUP F0.1)

<b>F0.1.15 Control place selection</b>	<b>Setting range: 0, 1, 2</b>	<b>Factory default: 0</b>
--	-------------------------------	---------------------------

This function defines three kinds of modes for selecting the control command source, as shown in Figure 7-7:

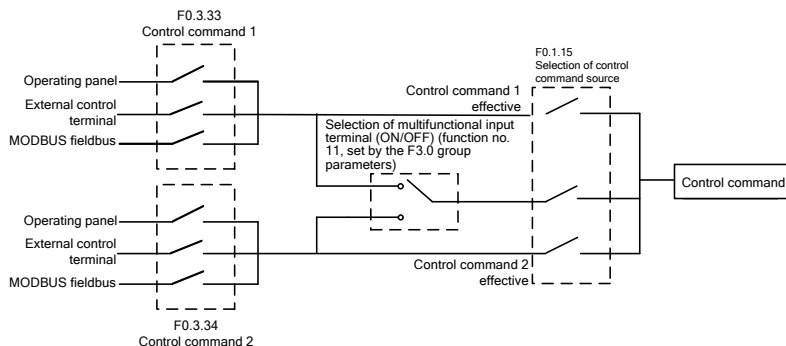

Figure 7-7 Sketch of selecting the control command sources

<b>F0.1.16 Selection of frequency set value</b>	<b>Setting range: 0~14</b>	<b>Factory default: 0</b>
---	----------------------------	---------------------------

The **V560** series inverter has two frequency setting sources (corresponding parameters **F0.2.25**, **F0.2.26**). This parameter determines 14 kinds of combined calculation methods for the two frequency setting sources. Figure 7-8 shows the structure sketch of the frequency setting channel.

The actual running direction of the inverter is the result of "XOR" between the set value direction (always being FWD direction for single polarity setting) and the running command direction.

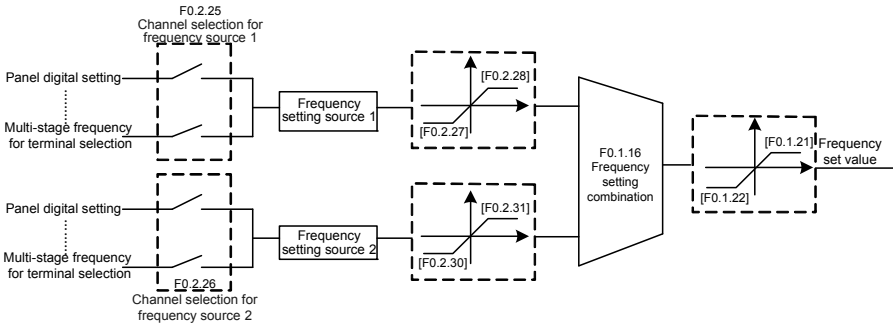

Figure 7-8 Structure sketch of frequency setting channel

### 0: Channel 1 Hz setting

The frequency setting source 1 is independently effective. In this case, the frequency set value is solely determined by the frequency setting source 1 and is named as the set value 1.

### 1: Channel 2 Hz setting

The frequency setting source 2 is independently effective. In this case, the frequency set value is solely determined by the frequency setting source 2 and is named as the set value 2.

### 2: Select Channel 1 or 2 Hz via input terminal (Function No. 12)

The frequency setting source is selected by the functional input terminal (Function No. 12) and the terminal function is set with F3.0 group parameters.

### 3: Selected via control place selection

The selection of frequency setting source is bound with the start-stop command. In this case, the running command source is bound with the frequency setting source. That is to say, if the running command source 1 is effective, the frequency setting source 1 is also effective; and if the running command source 2 is effective, the frequency setting source 2 is effective as well.

### 4: Channel 1 + Channel 2

Frequency set value = set value 1 + set value 2

The frequency combination curves under different status are shown as below:

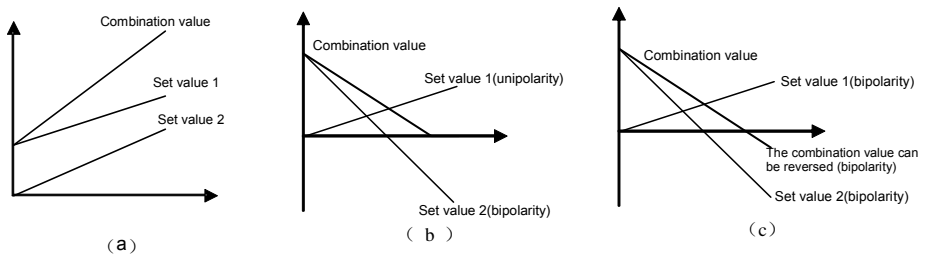

Figure 7-9-A Frequency combination sketch 1



- The combination result will only be in bipolarity when only two setting sources are set in bipolarity way. (Figure c)

**5: Channel 1 amplified by Channel 2**

Frequency set value = set value 1 \* (1+set value 2 / [F0.2.31])

The sketch of frequency combination setting is shown as below:

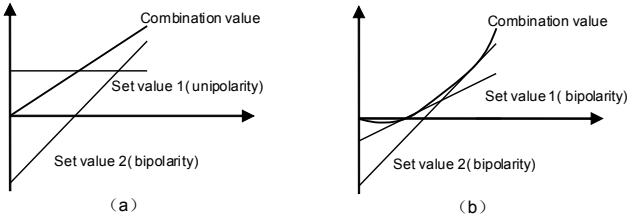

Figure 7-9-B Frequency combination sketch 2



- The combination results will only be in bipolarity when the setting source 1 is set in bipolarity way. (Figure b)

**6: Channel 1 - Channel**

Frequency set value = setting 1 - set value 2

The sketch of frequency combination setting is shown as below:

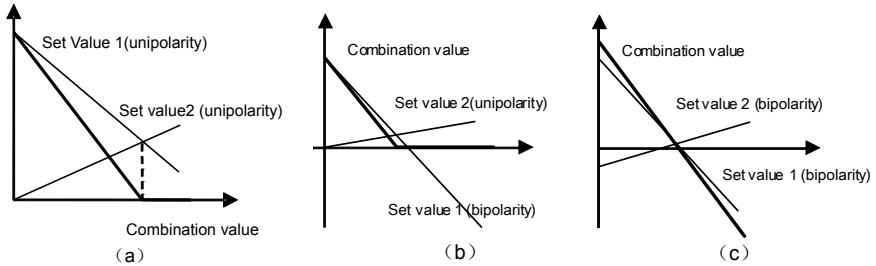

Figure 7-9-C Frequency combination sketch 3



- The combination result will only be in bipolarity when only two setting sources are set in bipolarity way. (Figure c)

**7: Channel 1 reduced by Channel 2**

Frequency set value = set value 1 \* (1 - set value 2 / [F0.2.31])

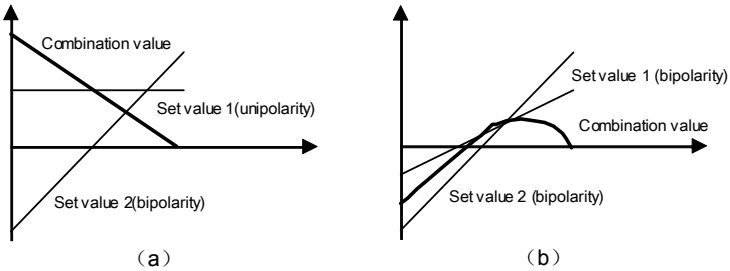

Figure 7-9-D Frequency combination sketch 4



- The combination results will only be in bipolarity when the setting source 1 is set in bipolarity way. (Figure b)

**8: Channel 1 reduced by Channel 2**

Frequency set value = set value 1 \* set value 2 / [F0.2.31]

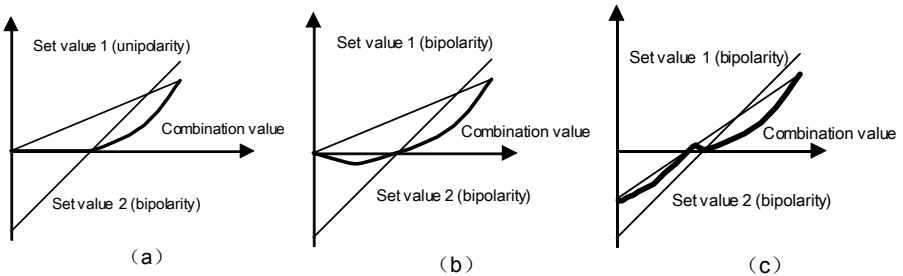

Figure 7-9-E Frequency combination sketch 5



- The combination results will only be in bipolarity when the setting source 1 is set in bipolarity way. (Figure b, Figure c)

**9: Highest value Channel 1 or Channel 2**

Frequency set value = **Max** (|set value 1|, |set value 2|)

The maximum value between the absolute values of set value 1 and set value 2 is taken as the frequency set value, and the combination value must be unipolar.

**10: Lowest value Channel 1 or Channel 2**

Frequency set value = **Min** (|set value 1|, |set value 2|)

The minimum value between the absolute values of set value 1 and set value 2 is taken as the frequency set value, and the combination value must be unipolar.

**11:  $\sqrt{(\text{Channel 1}) + \sqrt{(\text{Channel 2})}}$** 

Frequency set value =  $\sqrt{|\text{set value 1}| + \sqrt{|\text{set value 2}|}}$

The frequency set value is the total of the square root of the absolute value of set value 1 and set value 2, and the combination value must be unipolar.

**12:  $\sqrt{(\text{Channel 1} + \text{Channel 2})}$** 

Frequency set value =  $\sqrt{|\text{set value 1} + \text{set value 2}|}$

The frequency set value is square root of the absolute value of the total of set value 1 and set value 2, and the combination value must be unipolar.

**13:  $(\text{Channel1} \times \text{Scaling 1}) + (\text{Channel 2} \times \text{Scaling 2})$** 

Frequency set value =  $\text{set value 1} \times [\text{F0.1.18}] + \text{set value 2} \times [\text{F0.1.19}]$

Only when the two setting channels are both in the mode of bipolar setting, the combination results will show the characteristics of the bipolar setting.

**14:  $(\text{Channel1} \times \text{Scaling 1}) - (\text{Channel 2} \times \text{Scaling 2})$** 

Set value  $1 \times [\text{F0.1.18}] - \text{set value 2} \times [\text{F0.1.19}]$

Only when the two setting channels are both in the mode of bipolar setting, the combination results will show the characteristics of the bipolar setting.

**Remarks: after selecting the combination way of the frequency set value, the following aspects must be considered in order to get correct frequency set value**

- To set **F0.2.25** (channel selection for the frequency setting source 1) and **F0.2.26** (channel selection for the frequency setting source 2) to determine the given channel of the frequency setting source;
- To set **F0.1.18** (action coefficient of the frequency setting source 1) and **F0.1.19** (action coefficient of the frequency setting source 2) to determine the weighting coefficient of the frequency setting source;
- To Set **F0.2.27** (minimum set value of frequency source 1) and **F0.2.28** (maximum set value of frequency source 1) to limit the range of frequency set value of the frequency source 1, and to set **F0.2.30** (minimum set value of frequency source 2) and **F0.2.31** (maximum set value of frequency source 2) to limit the range of frequency set value of the frequency source 2;
- To set **F0.1.21** (upper limiting frequency) and **F0.1.22** (lower limiting frequency) to limit the range of the frequency set value.

<b>F0.1.17 Running direction (H)</b>	<b>Setting range: 0000~0021</b>	<b>Factory default: 0000</b>
--------------------------------------	---------------------------------	------------------------------

**\_\_ X :** Direction switching

**0: Void**

The running direction is controlled by the direction command.

**1: Negate**

The running direction is opposite to that directed by the direction command.

**\_\_ X \_ :** Direction locking

**0: Void**

The running direction is controlled by the direction command.

**1: FWD locking**

The motor will run in FWD direction No matter the FWD running command or REV running command is given.

## 2: REV locking

The motor will run in REV direction no matter the FWD running command or REV running command is given.



- The function of "Direction locking" ( \_\_x ) has precedence over the function of "Direction switching" ( \_\_x ).
- It can be set when the inverter is running. Be sure that the operation is safe.

<b>F0.1.20 Maximum output frequency</b>	<b>Setting range: 10.00~320.00Hz</b>	<b>Factory default: 60.00</b>
<b>F0.1.21 Upper limit frequency</b>	<b>Setting range: [F0.1.22]~Min (300.00Hz,[F0.1.20])</b>	<b>Factory default: 50.00</b>
<b>F0.1.22 Lower limit frequency</b>	<b>Setting range: 0.0Hz~[F0.1.21]</b>	<b>Factory default: 0.0</b>

The maximum output frequency is the allowable output maximum frequency of the inverter as set by users (maximum stator synchronous frequency of the asynchronous motor); The upper limiting frequency is the maximum frequency allowed for running of the asynchronous motor as set by users (the maximum frequency corresponding to the mechanical rotor of the asynchronous motor). The maximum output frequency must be higher than the upper limiting frequency; The lower limiting frequency is the minimum frequency allowed for running of the motor as set by users.

The maximum output frequency, upper limiting frequency and lower limiting frequency shall carefully set according to the actual nameplate parameters and operating status of the controlled motor and. The relationship among the three kinds of frequency is shown in Figure 7-10.

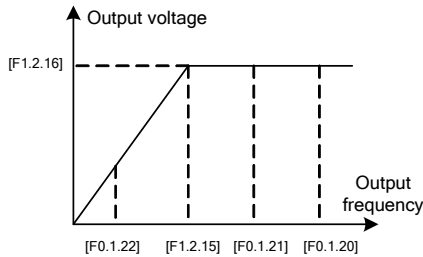

Figure 7-10 Frequency parameter definition sketch



- [F1.2.15] in Figure 7-10 represents the motor's reference frequency, and [F1.2.16] represents the motor's reference voltage.

<b>F0.1.23 FWD jog frequency</b>	<b>Setting range: 0.0Hz~[F0.1.21]</b>	<b>Factory default: 10.00</b>
<b>F0.1.24 REV jog frequency</b>	<b>Setting range: 0.0Hz~[F0.1.21]</b>	<b>Factory default: 10.00</b>

Jog running is a special running mode of the inverter. No matter the inverter is initially stopped or running, as long as the jog command is inputted, the inverter will transit to the jog frequency according to the preset jog acceleration and deceleration time. However, it is also influenced by the startup frequency and startup frequency duration as well as the functions of DC band-type braking, startup delay and startup pre-excitation.

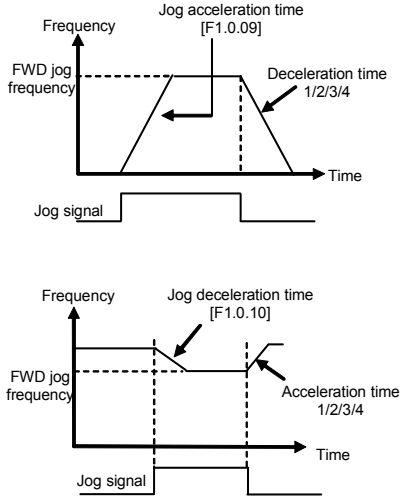

Figure 7-11 FWD jog running curve

## 7.3 FREQUENCY SETUP (GROUP F0.2)

<b>F0.2.25</b> Frequency setting channel 1	<b>Setting range: 00~29</b>	<b>Factory default: 2</b>
<b>F0.2.26</b> Frequency setting channel 2	<b>Setting range: 00~29</b>	<b>Factory default: 0</b>

The frequency set value determined via the frequency setting source 1 is named as the set value 1; And the frequency set value determined via the frequency setting source 2 is named as the set value 2.

### 0: Keypad entry 1 (keep value when stopped)

The frequency set value is determined by the value of the parameter **F0.2.29** (or **F0.3.32**). In the normal monitoring mode, it is applicable to make direct modification with the  $\wedge$  and  $\vee$  keys (or shuttle) on the panel. The modified values will not be saved and will get lost after power-on.

### 1: Keypad entry 2 (go to zero when stopped)

Similar to the case of "0" as above, the inverter will automatically clear current set value after stop.

### 2: Keypad entry 3 (keep value at power off)

Similar to the case of "0,1" as above, the inverter will automatically save the current set value after power-off, and take the saved value as the initial set value after power-on once again.

### 3: Setting of wheel potentiometer

Its function is equivalent to the high-precision panel potentiometer. The set resolution is the minimum quantitative value (e.g. 0.01 Hz), and data are saved in the internal memory of the panel.

### 4: Remote UP/DW 1 (keep value at power off)

Multifunctional terminals are used to directly increase, decrease (Function No. 15, 16) or clear (Function No. 17) the set frequency. The terminal function is selected by parameters **F3.0.00** ~ **F3.0.08**. The set data will not be saved and will get lost after power-off.

The relationship between the status setting combination of the three external switches and the current



frequency set value of the inverter is shown in Figure 7-2.

Preconditions for below instruction: multifunctional terminal **DI1** frequency or process **PID** setting **UP** function ([F3.0.00]=15), **DI2** sets frequency or process **PID DW** function ([F3.0.01]=16), and **DI5** sets **UP/DW** with frequency clear function ([F3.0.04]=17).

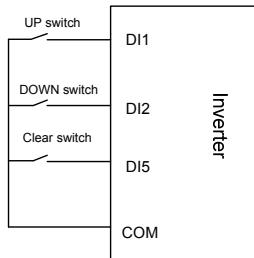

Figure 7-12 Terminal UP/DW wiring sketch

**Table 7-2 External Switch Status and Current Frequency Set Value of the Inverter**

Terminal Status			Set frequency
DI5	DI2	DI1	
OFF	OFF	OFF	Maintained
OFF	OFF	ON	Increased
OFF	ON	OFF	Decreased
OFF	ON	ON	Maintained
ON	Any	Any	Zero

#### 5: Remote UP/DW 2 (go to zero when stopped)

Similar to the case of "4" as above, the inverter will automatically clear current set value after stop.

#### 6: Remote UP/DW 3 (keep value at power-off)

Similar to the case of "4" as above, the set value will be saved automatically after power-off, and the initial set data will be the set value at the last power-off when the inverter is powered on once again.

#### 7: Remote UP/DW bipolar setting 1 (keep bipolar when stopped)

The basic operation is similar to that as stated in "the" and the difference is that: in the mode of "4", the set frequency is unsigned values (not containing direction information), and the setting range of the frequency is: 0~upper limiting frequency; while in the mode of "7", the set frequency is signed values (containing direction changing information), and the setting range of the frequency is: - upper limiting frequency upper limiting frequency.

The inverter's actual running direction is according to "XOR" calculation of the command direction (**FWD**, **REV**) and the set frequency direction.

#### 8: Remote UP/DW bipolar setting 2 (keep at power-off)

The basic operation is similar to the case of "7" as above. The set value will be saved automatically after power-off, and the initial set data will be the set value at the last power-off when the inverter is powered on once again.

#### 9: Analog input AI1

The frequency set value is given via the analog input AI1; For relevant characteristics please see the instructions of the parameters F4.0.00 and F4.0.01.

**10: Analog input AI2**

The frequency set value is given via the analog input AI2; For relevant characteristics please see the instructions of the parameters F4.0.02 and F4.0.03.

**11: Analog input AI3**

The frequency set value is given via the analog input AI3; For relevant characteristics please see the instructions of the parameters F4.0.04 and F4.0.05.

**12: AI1 bipolar setting**

The frequency set value is given by the bipolarity of the analog AI1 ([F4.0.00]~[F4.0.01]), and AI1 contains the direction changing information. For relevant characteristics please see the instructions of the parameters F4.0.00 and F4.0.01.

**13: AI3 bipolar setting**

The frequency set value is given by the bipolarity of the analog AI3 ([F4.0.04]~[F4.0.05]), and AI3 contains the direction changing information. For relevant characteristics please see the instructions of the parameters F4.00.04 and F4.00.05.

**14: Pulse follower input**

The frequency set value is given by the pulse input **Fin**.

**15: Pulse follower bipolar input**

The frequency set value is given by the pulse input **Fin** bipolarity, and the pulse signal contains the direction changing information.

**16: MODBUS communications 1 relative (relative set value)**

The frequency set value is given by the principal computer through **MODBUS** fieldbus (**RS485** communication port), and the set value (-**10000** ~ **10000**) is relative data and is corresponding to the upper limiting frequency.

**17: MODBUS communication 2 absolute (absolute set value)**

The frequency set value is given by the principal computer through **MODBUS** fieldbus (**RS485** communication port), and the set value (-**30000** ~ **30000**) is absolute value neglecting the decimal point) (e.g. the value 1500 corresponds to the set frequency **150.00Hz** in general mode.)

**18: AI1+AI2**

The frequency set value = the frequency value corresponding to the analog input AI1 + the frequency value corresponding to the analog input AI2

**19: AI2+AI3**

The frequency set value = the frequency value corresponding to the analog input AI2 + the frequency value corresponding to the analog input AI3

**20: AI2+pulse input Fin**

The frequency set value = the frequency value corresponding to the analog input AI2 + the frequency value corresponding to the pulse input **Fin**

**21: AI1\*AI2/full scale of AI2 (10V)**

The frequency set value = the frequency value corresponding to AI1 \*the frequency value corresponding to AI2/the frequency corresponding to the maximum input of AI2.

**22: AI1/AI2**

The frequency set value= the frequency value corresponding to AI1/the frequency value corresponding to AI2.

**23: Process PID output**

The frequency set value is given by the process **PID** output. This option is mainly for the system in which the **PID** running output needs to be combined with other setting channel for running. In general running system, this value does not need to be selected. **PID** output will automatically participate in setting competition according to the frequency setting priority.

#### 24: Compensation PID output

The frequency set value is given by the compensation **PID** output. This option is mainly for the system in which compensation **PID** running output needs to be combined with other setting channel for running. In general running system, this value does not need to be selected. The compensation **PID** output will automatically participate in setting competition according to the frequency setting priority.

#### 25: Disturbance running frequency

The frequency set value is given by the disturbance running frequency. This option is mainly for the system in which the disturbance running output needs to be combined with other setting channel for running. In general running system, this value does not need to be selected. The disturbance output will automatically participate in setting competition according to the frequency setting priority.

#### 26: Auto preset speeds

The frequency set value is given by the multi-stage running frequency. This option is mainly for the system in which the multi-stage running output needs to be combined with other setting channel for running. In general running system, this value does not need to be selected. The multi-stage running output will automatically participate in setting competition according to the frequency setting priority.

#### 27: Preset speeds via terminals

The frequency set value is determined by the combination status of the four multifunctional input terminals (Function No. 1, 2, 3, 4), and the terminal function is set by the parameters **F3.0.00~F3.0.08**. This way allows for multi-stage frequency running.

#### 28: Simulated analog input SA11

#### 29: Simulated analog input SA12

The frequency setting source and set value are determined by the virtual input parameter Group F4.4.50 ~ F4.4.54.

<b>F0.2.27</b> Min frequency channel 1	<b>Setting range:</b> 0.0Hz~[F0.2.28]	<b>Factory default:</b> 0.0
<b>F0.2.28</b> Max frequency channel1	<b>Setting range:</b> [F0.2.27]~[F0.1.20]	<b>Factory default:</b> 50.00
<b>F0.2.30</b> Min frequency channel 2	<b>Setting range:</b> 0.0Hz~[F0.2.31]	<b>Factory default:</b> 0.0
<b>F0.2.31</b> Max frequency channel 2	<b>Setting range:</b> [F0.2.30]~[F0.1.20]	<b>Factory default:</b> 50.00

This group of parameters confines the range of frequency allowed to be set for two frequency setting sources.

<b>F0.2.29</b> Keypad incremental value channel 1	<b>Setting range:</b> 0.0Hz~[F0.2.28]	<b>Factory default:</b> 0.0
<b>F0.2.32</b> Keypad incremental value channel 2	<b>Setting range:</b> 0.0Hz~[F0.2.31]	<b>Factory default:</b> 0.0

The frequency command value at the time of panel digital setting can be directly modified with the ▲, ▼ keys (or shuttle) on the panel in the normal monitoring mode, and the set frequency can be also modified by means of parameter modification.

## 7.4 CONTROL COMMAND SOURCE (GROUP F0.3)

<b>F0.3.33 Control command 1</b>	<b>Setting range: 0~2</b>	<b>Factory default: 0</b>
<b>F0.3.34 Control command 2</b>	<b>Setting range: 0~2</b>	<b>Factory default: 0</b>

To select the input physical channel of the inverter control commands (start, stop, forward, reverse, jog and reset, etc ).

### 0: Operating panel

The running control command is given via the operating panel. Please see Chapter 5 for the use of the operating panel.

### 1: External control terminal

The running control command is given via external control commands, and the terminal function is set by the parameter **F3.0**.

### 2: MODBUS fieldbus/standard expansion card configuration

The running control command is given via **MODBUS** fieldbus.

<b>F0.3.35 External control quick setup (H)</b>	<b>Setting range: 0000~0013</b>	<b>Factory default: 0000</b>
---	---------------------------------	------------------------------

### \_\_\_ X : Control command action mode

Preconditions for below instructions: the multifunctional terminal **DI3** is for **FWD** command function ([F3.0.02]=7), **DI4** is for **REV** function ([F3.0.03]=8), and **DI5** is for three-line running control function ([F3.0.04]=19).

#### 0: Two wire mode 1

<b>DI4</b>	<b>DI3</b>	<b>Running command</b>
OFF	OFF	Stop
OFF	ON	FWD
ON	OFF	REV
ON	ON	Stop

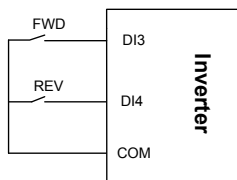

Figure 7-13-A Two wire running mode 1

#### 1: Two wire mode 2

<b>DI4</b>	<b>DI3</b>	<b>Running command</b>
OFF	OFF	Stop
OFF	ON	FWD
ON	OFF	Stop
ON	ON	REV

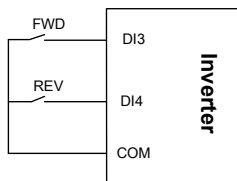

Figure 7-13-B Two wire running mode 2

## 2: Three wire mode 1

When **K0** is engaged, **FWD** and **REV** control is effective; and when **K0** is unengaged, **FWD** and **REV** control is void, and the inverter will stop.

**DI3** terminal ascending edge indicates FWD running command and **DI4** terminal ascending edge indicates REV running command.

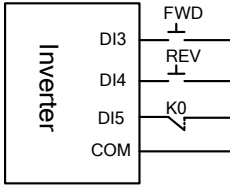

Figure 7-14-A Three wire running mode 1

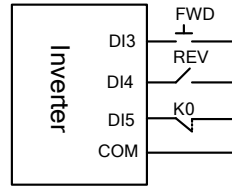

Figure 7-14-B Three wire running mode 2

## 3: Three wire mode 2

When **K0** is engaged, **FWD** and **REV** control is effective; and when **K0** is unengaged, **FWD** and **REV** control is void, and the inverter will stop.

**DI3** terminal ascending edge indicates running command; **DI4** terminal disconnection indicates FWD running command, and **DI4** terminal engagement indicates REV running command.

**\_\_X\_**: Control first starting mode

**0**: Running signal level starting

**1**: Running signal rising edge starting

Note : The signal given by two-line mode running command is level signal, and when the terminal is at effective status, the inverter will automatically start after power-one. In the system in which power-on auto start is not expected, it is applicable to select the way of rising edge start.

## 7.5 START AND STOP (GROUP F0.4)

<b>F0.4.37 Start/Running permission(H)</b>	<b>Setting range: 0000~1202</b>	<b>Factory default: 0000</b>
--	---------------------------------	------------------------------

**\_\_X**: Start permission

**0**: Function closed

The inverter can start without start permission signal.

**1**: Permitted when the multifunctional terminal is effective

The inverter will not start until it is defined that the multifunctional input terminal (Group **F3.0**) of the start permission (Function No.42) is continuously effective; Start is forbidden when it is void, and the inverter which is running will stop freely (alarm code: **aL.031**). The inverter will not start again until the rising edge of the starting signal is detected.

**2**: Command word from standard fieldbus (effective when standard expansion card is equipped)

The start permission signal is from the bus command word.

**\_X\_\_**: Running permission

**0**: Function closed

The inverter can run without running permission signal.

### 1: Permitted when the multifunctional terminal is effective (Function No. 43)

The inverter will not start until the multifunctional input terminal (Group F3.0) which is defined to be running permissible (Function No.43) is effective; If it is void, the inverter will stop in the way defined by the kilometer of this parameter, and will then automatically run again after signal recovery.

### 2: Command word from standard fieldbus (effective when standard expansion card is equipped)

The start permission signal is from the bus command word.

**X \_\_\_ :** The action mode when the running permission signal is void

#### 0: Free stop

The inverter stops outputting, and the motor stops freely.

#### 1: Deceleration stop

The inverter will stop at deceleration mode according to preset deceleration time.

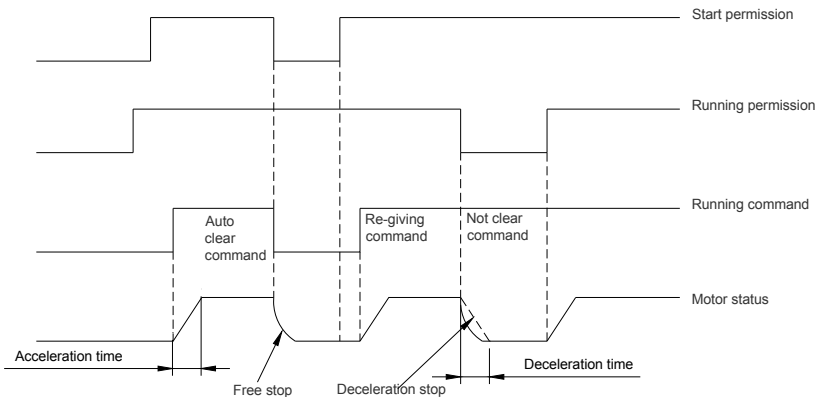

Figure 7-15 Schematic diagram of start process

<b>F0.4.38 Start/Stop Mode(H)</b>	<b>Setting range: 0000~0101</b>	<b>Factory default: 0000</b>
-----------------------------------	---------------------------------	------------------------------

**\_\_\_ X : Start mode**

#### 0: Normal start

There are no special requirements for most load start mode. normal start mode will be adopted.

#### 1: Revolution tracking start

It is applicable to the occasion of fault resetting and restart and restart after power-off. The inverter will automatically judge the running speed and direction of the motor, and starts the rotating motor in a smooth and impact-free way according to the detection and judge results; See below figure for the revolution tracking start sketch.

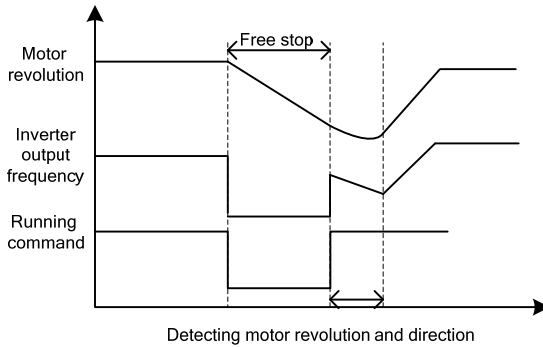

Figure 7-16 Revolution tracking start sketch

## **\_ X \_ : Stop mode**

### **0: Deceleration stop**

In the case of deceleration stop, the inverter will gradually reduce the output frequency according to the preset deceleration time until it stops.

### **1: Free stop**

At stop, the inverter outputs zero frequency and clocks output signals, and the motor will stop in a free sliding way according to inertia.

At free stop, if it is needed to restart the motor before the motor stops running completely, it is necessary to appropriately configure the revolution tracking start function; Otherwise, it will leads to overcurrent or overvoltage fault protection.

If the motor has not stopped completely in deceleration way, because of high load inertia of the field work and short deceleration time, it is then applicable to start DC band-type braking control. See the instructions of the parameter **F0.4.44** for details.

<b>F0.4.39 Start frequency</b>	<b>Setting range: 0.0Hz~50.00Hz</b>	<b>Factory default: 0.50</b>
<b>F0.4.40 Start frequency hold time</b>	<b>Setting range: 0.00~10.00Sec.</b>	<b>Factory default: 0.0</b>

The start frequency means the initial frequency when the inverter starts up, and is not limited by the lower limiting frequency **F0.1.22**.

The start frequency holding time means the duration of operation at the start frequency, and can be set according to actual needs. When it is set to 0, the start frequency is void.

For the system with high inertia, heavy load and high requirement of start torque, the start frequency can effectively overcome the difficult of start, and the start frequency is also effective in each acceleration process when the inverter switches between forward and reverse running.

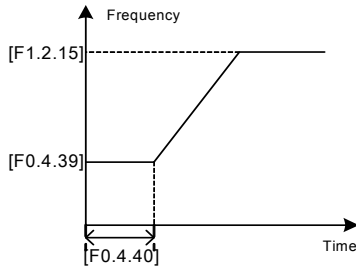

Figure 7-17 Start frequency sketch

<b>F0.4.41 Start pre-excitation current</b>	<b>Setting range: 0.0~100%</b>	<b>Factory default: 35.0</b>
<b>F0.4.42 Start pre-excitation time</b>	<b>Setting range: 0.00~10.00Sec.</b>	<b>Factory default: 0.10</b>

It costs some time to develop air gap flux for asynchronous motor (approaching to the constant of the rotor time). When it is at stop status before the motor is started, in order to get enough start torque, it is a must to develop the air gap flux. Therefore, it is needed to start pre-excitation for the asynchronous motor. See Figure 7-18 for the pre-excitation process.

The set value of start pre-excitation current is the percentage with respect to the inverter rated output current.

The start pre-excitation time means the duration in which the inverter inputs start pre-excitation current for the motor.



- When the rated current of the adapter motor differs greatly from the rated current of the inverter, please carefully set the pre-excitation current (F0.4.41), as excessive setting may damage the motor.

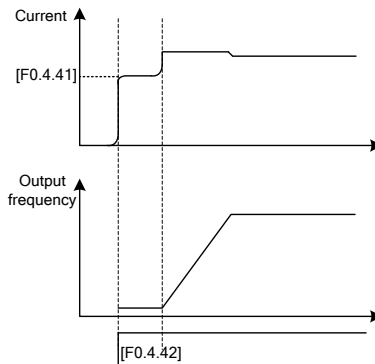

Figure 7-18 Start pre-excitation output



<b>F0.4.43 Start delay</b>	<b>Setting range:</b> 0.00~10.00Sec.	<b>Factory default: 0.0</b>
----------------------------	---	-----------------------------

Start delay means the waiting time before the inverter starts after receiving the running command.

<b>F0.4.44 DC band-type brake control</b>	<b>Setting range: 0000~0001</b>	<b>Factory default: 0</b>
---	---------------------------------	---------------------------

#### \_\_\_ X : DC band-type brake control

The DC band-type brake means to lead DC current into the motor rotor so as to generate braking torque. The DC band-type braking function cannot be used when synchronous motor is driven.

When both the set value and the actual speed of the motor has decreased below [F0.4.45], the inverter will stop generating sine current but will inject direct current to the motor, and the current value is to be set by the parameter [F0.4.47]. When the given speed or the motor speed has surpassed the parameter [F0.4.45], the inverter will stop DC power supply and restore to the normal running status.

If it is started, the permission signal will be disconnected, and the DC band-type brake will be void.

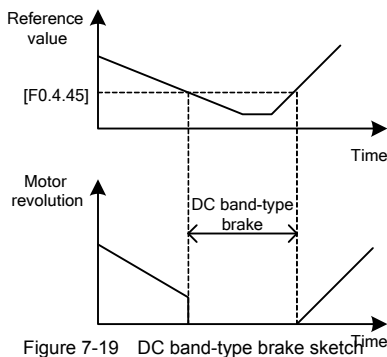

Figure 7-19 DC band-type brake sketch



- Injecting current to the motor may lead over-temperature of the motor. In the circumstances where long-time DC band-type brake is needed, forced air-cooling motor should be used. During the long time of band-type braking, if there is constant load in the motor band-type brake, DC band-type brake will not guarantee that the motor shaft will not rotate.

<b>F0.4.45 DC injection brake application frequency</b>	<b>Setting range: 0.0Hz~[F0.1.21]</b>	<b>Factory default: 2.00</b>
---	---------------------------------------	------------------------------

In the deceleration and stop process of the inverter, when the output frequency is lower than the DC band-type brake/brake start frequency/speed, the DC band-type brake/brake function will be started.

<b>F0.4.46 DC brake action time</b>	<b>Setting range: 0.00~10.00Sec.</b>	<b>Factory default: 0.0</b>
<b>F0.4.47 DC injection brake current level</b>	<b>Setting range: 0.0~100%</b>	<b>Factory default: 50.0</b>

The DC brake time is the duration of the output DC braking current. If it is selected that the external terminal stop DC braking is effective, the parameter of DC braking action time will be void.

The DC band-tape brake/brake injection current means the brake current outputted at the time of inverter DC band-type brake/brake. Its set value is the percentage with respect to the rated current.

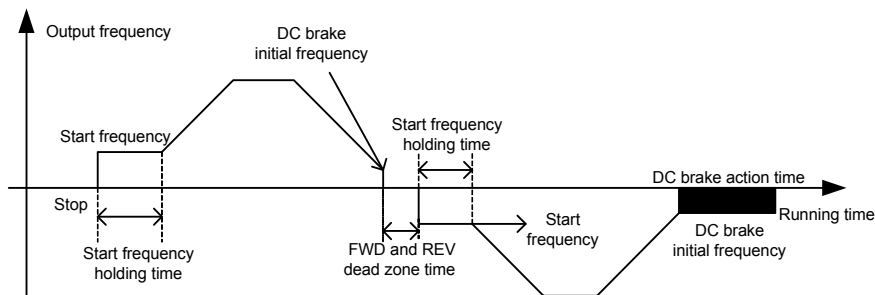

Figure 7-20 Stop DC brake sketch

<b>F0.4.48 Restart after power-off</b>	<b>Setting range: 0, 1</b>	<b>Factory default: 0</b>
--	----------------------------	---------------------------

It is mainly for the trigger starting modes including “panel control, bus control and three-line control”. If the function of restart after power-off is set to be effective, when the inverter is powered off, the running command/status before power-off will be automatically saved, and it will automatically restore to the running status before power-off after the waiting time after power-on again.

In case of the restart after power-off, it will resume running in the mode of restart at detected speed.

<b>F0.4.49 Restart delay time</b>	<b>Setting range: 0.1~10.0Sec.</b>	<b>Factory default: 0.5</b>
-----------------------------------	------------------------------------	-----------------------------

It means the time of waiting status before the inverter automatically executes the function of restart after power-off.

<b>F0.4.50 Direction change delay time</b>	<b>Setting range: 0.00~5.00Sec.</b>	<b>Factory default: 0.00</b>
--	-------------------------------------	------------------------------

The forward and reverse transition dead time is used to set the waiting time for the motor to shift from FWD to REV or from REV to FWD. This function is used to overcome reversal current compact caused by mechanical dead zone, as shown in Figure 7-21.

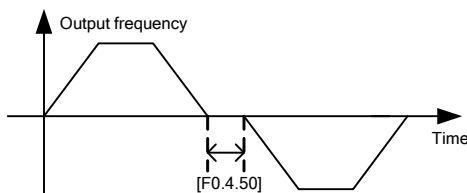

Figure 7-21 FWD and REV transition dead zone Sketch

**F0.4.51 Forward and reverse switch mode****Setting range: 0, 1****Factory default: 0****0: Switch at zero point**

To switch between FWD and REV at the zero point.

**1: Start frequency switch**

To switch between the FWD and REV at the start frequency. See the following figure:

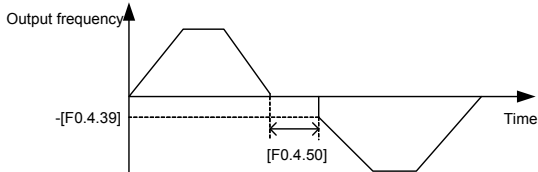

Figure 7-22 Sketch of start frequency FWD and REV switching

**F0.4.52 Zero speed (frequency) detection level****Setting range: 0.00~100.00Hz****Factory default: 0.10 Hz****F0.4.53 Zero speed delay time****Setting range: 0.00~10.00Sec.****Factory default: 0.05**

When the inverter output frequency is lowered to zero, it will immediately lock the output. At this time, the motor revolution may not be at zero, but the motor is completely at the free stop status, and will slide to stop.

Within the delay time, when the inverter output frequency is lower than the zero speed (frequency) detected level [F0.4.52], within the zero speed delay time [F0.4.53], the inverter will keep working and output a DC current, and the motor will keep excitation. The inverter may rapidly restart at any time.

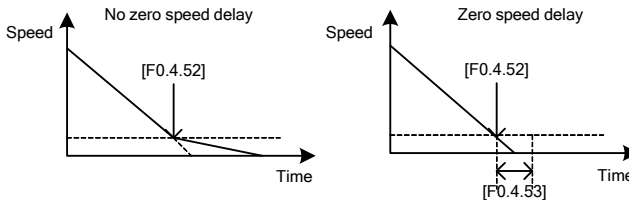

Figure 7-23 Comparison diagram when with or without zero speed delay

**F0.4.54 Emergency stop mode (EMS)****Setting range: 0, 1****Factory default: 0**

This parameter defines the stop mode after the inverter has received an emergency command (Function No. 14, to be set by the Group F3.0 parameters).

## 7.6 ACCEL AND DECEL CHARACTERISTICS (GROUP F1.0)

<b>F1.0.00 Acceleration and deceleration modes</b>	<b>Setting range: 0000~0011</b>	<b>Factory default: 0000</b>
--	---------------------------------	------------------------------

\_\_\_ X : **Accel and decel mode**

### 0: **Liner acceleration and deceleration**

The output frequency of the inverter increases or decreases according to fixed speed. The output frequency has liner relationship with the acceleration and deceleration time, and steadily increases or decreases according to constant gradient.

### 1: **S curve acceleration and deceleration**

The output frequency of the inverter increases or decreases according to grading speed, and the characteristics of S curve is determined by the parameter [F1.0.01] and [F1.0.02]. This function is mainly to reduce noise and ventilation during acceleration and deceleration, and decrease impact of the starting and stop load. When the load inertia is excessive, leading to overload fault during deceleration, it can be improved by adjusting the parameter setting ([F1.0.01] and [F1.0.02]) of S deceleration curve, so as to reasonably adjust the deceleration rate at different frequency.

\_\_ X \_ : **Accel and decel unit**

### 0: **Sec. (Second)**

The acceleration and deceleration time is in the unit of second, and is at factory default value.

### 1: **Min. (Minute)**

The acceleration and deceleration time is in the unit of minute.

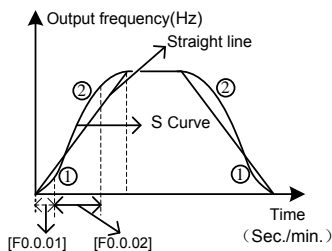

Figure 7-24 Acceleration and deceleration curve

<b>F1.0.01 % of S curve at the bottom</b>	<b>Setting range: 5.0~100.0-[F1.0.02]</b>	<b>Factory default: 15.0</b>
<b>F1.0.02 % of S curve at mid section</b>	<b>Setting range: 20.0~100.0-[F1.0.01]</b>	<b>Factory default: 70.0</b>

Define the curve parameters of acceleration and deceleration of S curve.

As shown in item ① in Figure 7-24, the acceleration starting/deceleration ending period of S curve is indicated by the percentage of the total acceleration and decoration time.

As shown in item ② in Figure 7-24, the acceleration rising/deceleration decreasing period of S curve is indicated by the percentage of the total acceleration and decoration time.

<b>F1.0.03~F1.0.08</b> Acceleration/ deceleration time 1/2/3	<b>Setting range: 0.01~600.00</b>	<b>Factory default: ☆</b>
<b>F1.0.09</b> Acceleration 4/jog acceleration time	<b>Setting range: 0.01~600.00</b>	<b>Factory default: ☆</b>
<b>F1.0.10</b> Deceleration 4/jog deceleration time	<b>Setting range: 0.01~600.00</b>	<b>Factory default: ☆</b>

The acceleration time means the time required for the inverter to accelerate from 0.00Hz to maximum output frequency [F0.1.20].

The deceleration time means the time required for the inverter to decelerate from the maximum output frequency [F0.1.20] to 0.00Hz.

V560 series inverters are defined with 4 kinds of acceleration/deceleration time. The acceleration/ deceleration time 1~4 during the running process of the inverter can be selected through different combinations of external terminals. During simple PLC running, it is also applicable to use them as the acceleration and deceleration time at the time of switching among different running frequency at each stage. See instructions of F6.1 group parameters for detail.

The acceleration/deceleration time 4/jog acceleration/deceleration time are also used as the acceleration and deceleration running time at the status of jog running. The jog frequency has the highest priority. At any state, the inverter will immediately transit to the jog frequency running state according to the preset jog acceleration and deceleration time as long as the jog command is inputted. (See the instructions of the functional parameter F0.1.23 and F0.1.24) The unit (Sec., Min.) of the acceleration and deceleration time is determined by the tens' digit of the parameter F1.0.11.

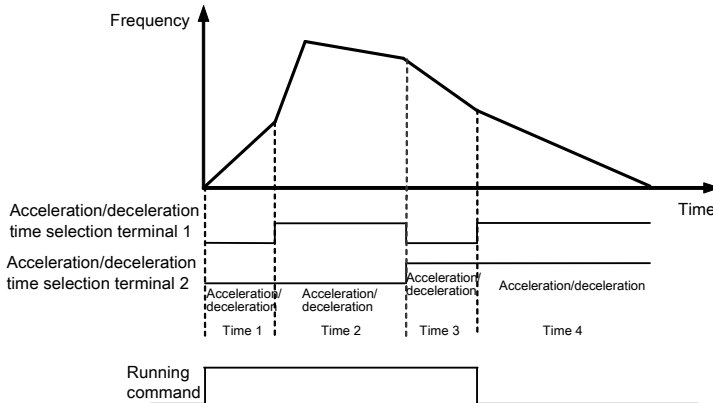

Figure 7-25 External terminal selection mode for acceleration and deceleration time

<b>F1.0.11</b> EMS emergency stop and deceleration time	<b>Setting range: 0.01~600.00</b>	<b>Factory default: ☆</b>
--	-----------------------------------	---------------------------

The time for decelerating from the maximum output frequency [F0.1.20] to the zero frequency will only function when the inverter stops in deceleration way (F0.4.54 is set to 0) after receiving EMS emergency stop command (Function No. 14).

## 7.7 CARRIER FREQUENCY (GROUP F1.1)

<b>F1.1.13 Carrier frequency</b>	<b>Setting range:</b> 1.5~12.0KHz(FF.4.43=##0#) 1.5~15.0KHz(FF.4.43=##1#)	<b>Factory default:</b> ☆
----------------------------------	---	---------------------------

It is the switch frequency determining the inverter's internal power module. The allowable maximum carrier frequency is relevant with the inverter model. The carrier frequency mainly influences the audio noise and heat effect during running. When mute running is required, it is applicable to appropriately increase the value of the carrier frequency, but the maximum load allowable for the inverter may be somewhat reduced, accompanied by somewhat increase of interference of the inverter to the outside world.

For the circumstances where the motor wire is too long, it may lead to leaking current between motor wires and between the wire and the ground. When the ambient temperature is too high and the motor load is too high, or the inverter is failed due to above reasons, it is suggested to appropriately decrease the carrier frequency to improve thermal characteristics of the inverter.

<b>F1.1.14 Carrier characteristics</b>	<b>Setting range: 0000~2111</b>	<b>Factory default: 0011</b>
--	---------------------------------	------------------------------

This parameter is used to set some characteristics relevant with the carrier (binary system setting), and usually needs not be modified.

### \_\_\_X : Load linkage adjustment

When this function is effective, if the load current is excessive, the carrier frequency will be automatically decreased in order to ensure safe running of the inverter.

### \_\_X\_ : Temperature linkage adjustment

When this function is effective, the inverter will automatically decrease the carrier frequency if the ambient temperature is too high.

### \_X\_\_ : Reference frequency linkage adjustment

When this function is effective, the inverter will appropriately decrease the carrier frequency if the output frequency is too low.

### X\_\_\_ : Modulation mode

#### 0: Asynchronous modulation

#### 1: Synchronous modulation

When the ratio between the carrier frequency and inverter output frequency is below 20, it is suggested to set to the synchronous modulation mode so as to promote stability.

#### 2: Noise smoothing

In this mode, the inverter's carrier frequency is uncertain random value, which is favorable for reducing audio noise and fixed frequency interference.

## 7.8 V/F PARAMETERS AND OVERLOAD PROTECTION (MOTOR 1) (GROUP F1.2)

<b>F1.2.15 Reference frequency of motor 1</b>	<b>Setting range: 5.00~300.00Hz</b>	<b>Factory default: 50.00</b>
<b>F1.2.16 Reference voltage of motor 1</b>	<b>Setting range: 50~500V</b>	<b>Factory default: 380/220</b>

The reference frequency means the minimum frequency when the inverter outputs the maximum voltage, and generally is rated frequency of the motor.

The reference voltage means the output voltage when the inverter outputs the reference frequency, and generally is rated voltage of the motor.

This group of parameters is set according to the motor's parameters, and do no need to be modified except for special circumstances.

<b>F1.2.17 V/F curve selection for motor1</b>	<b>Setting range: 0, 1, 2, 3</b>	<b>Factory default: 0</b>
---	----------------------------------	---------------------------

Set the corresponding curve between the inverter output voltage and output frequency. See the following figure.

### 0: Customized curve

When this mode is selected, users can set any desired V/F curve via this group of parameters (Group F1.2).

### 1: 1.2 times squares curve

The outputted is 1.2 times-square descending torque characteristics curve. See the curve 1 in the figure.

It is suitable for torque load of fans and pumps.

### 2: 1.5 times squares curve

The outputted is 1.5 times-square descending torque characteristics curve. See the curve 2 in the figure. It is suitable for torque load of fans and pumps. The energy saving effect of the descending torque curve is slightly increased compared with the constant torque curve.

### 3: Second square curve

The outputted is 2.5 times-square descending torque characteristics curve. See the curve 3 in the figure. It is suitable for torque load of fans and pumps. If it is not steady during light load operation, please switch to 1.5 times-square curve for operation.

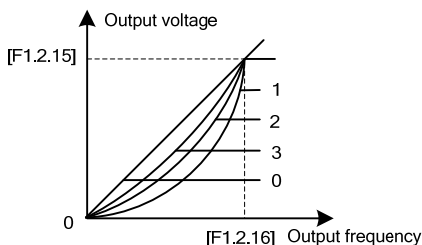

Figure 7-26 V/F curve

<b>F1.2.18 Torque boost motor 1</b>	<b>Setting range: 0.0~20.0%</b>	<b>Factory default: ☆</b>
-------------------------------------	---------------------------------	---------------------------

It is used to improve the inverter's low frequency torque characteristics. When the inverter runs at low frequency, it will make compensation for the inverter's output voltage. Its set value is the percentage relative to the motor's reference voltage [F1.2.16]. See Figure 7-27-A and Figure 7-27-B.

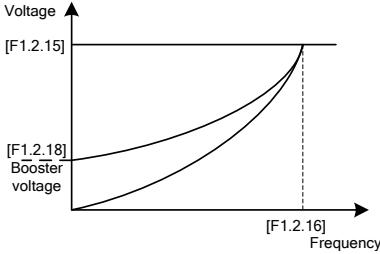

Figure 7-27-A Sketch of torque booster for descending torque curve

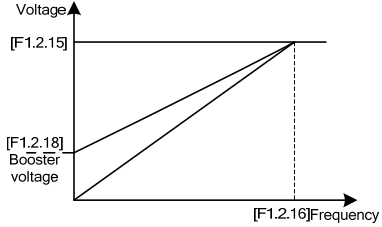

Figure 7-27-B Sketch of torque booster for constant torque curve

<b>F1.2.19 V/F curve 1<sup>st</sup> frequency motor 1</b>	<b>Setting range: 0.0~[F0.1.21]</b>	<b>Factory default: 0.0</b>
<b>F1.2.20 V/F curve 1<sup>st</sup> voltage of motor 1</b>	<b>Setting range: 0~500V</b>	<b>Factory default: 0.0</b>
<b>F1.2.21 V/F curve 2<sup>nd</sup> frequency motor 1</b>	<b>Setting range: 0.0~[F0.1.21]</b>	<b>Factory default: 0.0</b>
<b>F1.2.22 V/F curve 2<sup>nd</sup> voltage of motor 1</b>	<b>Setting range: 0~500V</b>	<b>Factory default: 0.0</b>
<b>F1.2.23 V/F curve 3<sup>rd</sup> frequency motor 1</b>	<b>Setting range: 0.0~[F0.1.21]</b>	<b>Factory default: 0.0</b>
<b>F1.2.24 V/F curve 3<sup>rd</sup> voltage of motor 1</b>	<b>Setting range: 0~500V</b>	<b>Factory default: 0.0</b>

This group of parameters is used to flexibly set V/F curve desired by users, as shown in Figure 7-28.

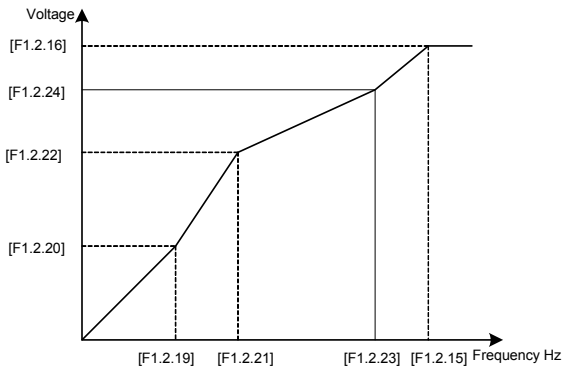

Figure 7-28 V/F customized curve



<b>F1.2.25 Slip frequency compensation for motor 1</b>	<b>Setting range: 0~150%</b>	<b>Factory default: 0</b>
--	------------------------------	---------------------------

The actual revolution difference of the motor may vary with the change of the load. Through setting of this parameters, the inverter will automatically adjust the inverter's output frequency according to the load, so as to offset the influence of the load to the motor revolution.

This parameter is only effective to V/F control mode.

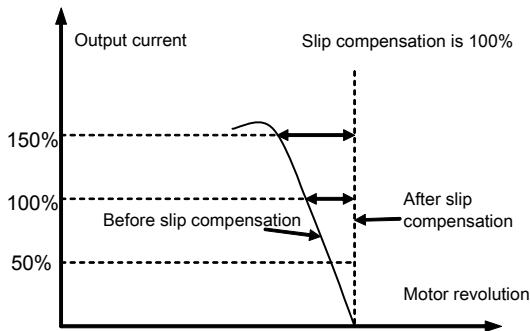

Figure 7-29 Slip frequency compensation sketch

## 7.9 V/F PARAMETERS AND OVERLOAD PROTECTION (MOTOR 2) (GROUP F1.3)

<b>F1.3.27 Reference frequency of motor 2</b>	<b>Setting range: 0~150%</b>	<b>Factory default: 0</b>
....		
<b>F1.3.37 Reference voltage of motor 2</b>	<b>Setting range: 0~150%</b>	<b>Factory default: 0</b>

The V/F control parameter when the motor 2 is selected is defined the same as parameters F1.2.15~F1.2.25.

## 7.10 STEADY RUNNING (GROUP F1.4)

<b>F1.4.39 Accel/decel current limit level</b>	<b>Setting range:120~180%</b>	<b>Factory default: 160</b>
--	-------------------------------	-----------------------------

When the frequency inverter is in acceleration and deceleration running, for the acceleration and deceleration time does not match to the motor inertia or load breaks, there can be phenomenon of steep current rise. This parameter is used for setting the allowed output level when frequency inverter is in state of acceleration. Setting value is the relevant percentage of rated output current of frequency inverter.

When the output current of frequency inverter exceeds the specified level of this parameter, acceleration and deceleration time will be automatically delayed, to ensure the output current limited within the range of this level, refer to the figure below. Thus, for occasions requiring shorter acceleration time, acceleration torque level shall be properly improved.

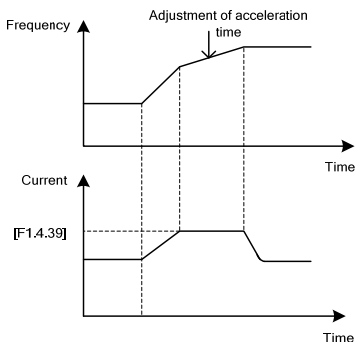

Figure 7-30 Schematic diagram of current limit for acceleration and deceleration

<b>F1.4.40 Strong start current limiting level</b>	<b>Setting range: 120~200%</b>	<b>Factory default: 160</b>
<b>F1.4.41 Strong start current holding time</b>	<b>Setting range: 0.00~5.00Sec.</b>	<b>Factory default: 0.0</b>

Function is similar with [F1.4.39], limit the current value when frequency inverter is in acceleration and starting. For some systems with large inertia, or requires to overcome great static friction at start, large starting current can be set for a certain time ([F1.4.41]), to meet the requirement. Setting value is the relevant percentage of rated output current of frequency inverter.



➤ F1.4.41 is set as zero, it means the function of current limit of strong start is closed.

<b>F1.4.42 Trip suppression selection</b>	<b>Setting range: 0000~0112</b>	<b>Factory default: 0111</b>
---	---------------------------------	------------------------------

**\_\_X : Overvoltage suppression adjustor**

When setting is valid, for load with energy feedback, in order to suppress overvoltage, frequency inverter may lift output frequency automatically, making it exceed selected frequency (limited by upper limiting frequency). Be attention if it is dangerous to the equipment safety when setting.

**\_\_X : Undervoltage suppression adjustor**

When setting is valid, undervoltage caused by sudden fall of grid voltage, frequency inverter may lower output frequency automatically, accessing into feedback braking state, to keep running with mechanical energy for a certain time to ensure the normal running of equipment.

**\_X : Frequency modulation and current**

When setting is valid, if the output current exceeds the maximum current [F1.4.47], frequency inverter will lower output frequency automatically.

**X : Failure Auto Recovery Mode**

Setting effective, failure auto recovery mode is normal start, setting not effective, failure auto recovery mode is speed tracking start

<b>F1.4.43 Overvoltage trip level (DC BUS)</b>	<b>Setting range: 720~800V</b>	<b>Factory default: 740</b>
<b>F1.4.44 Overvoltage adjusting gain</b>	<b>Setting range: 0.10~10.00</b>	<b>Factory default: 1.00</b>

When the motor is dragging overvoltage or in process of deceleration stop with large inertia, it may access into recycle braking state, causing rapid rise of direct current bus voltage of frequency inverter, leading to overvoltage protection action. When frequency inverter detects the direct current bus voltage exceeds [F1.4.43], it will adjust output frequency (extended deceleration time or increase frequency), to ensure continually safe running.

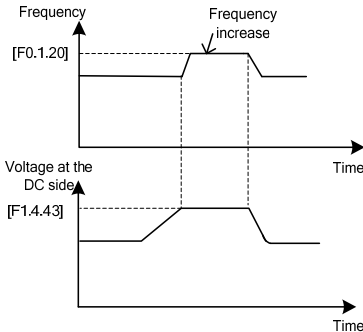

Figure 7-31-A Overvoltage suppression during steady running

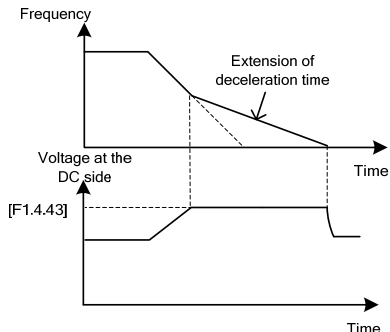

Figure 7-31-B Overvoltage suppression during deceleration process



- The larger the overvoltage adjusting gain is, the more obvious the suppression is, but it may lead to unsteady running.

<b>F1.4.45 Undervoltage trip level (AC input)</b>	<b>Setting range: [FF.2.35]~480V</b>	<b>Factory default: 400</b>
<b>F1.4.46 Undervoltage trip level gain</b>	<b>Setting range: 0.10~10.00</b>	<b>Factory default: 1.00</b>

When frequency inverter detects the direct current bus voltage is below [F1.4.45], it may lower output frequency automatically, accessing into recycle braking state, keep running with mechanical energy. The larger the undervoltage adjusting gain is, the stronger undervoltage suppression is.

This function plays very efficiently in large inertia load application occasions like centrifugal pump and draught fan.

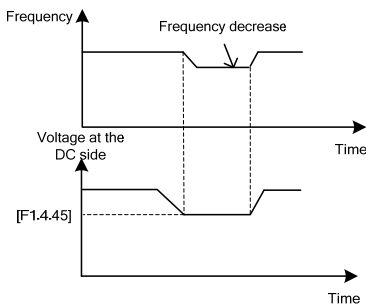

Figure 7-32-A Sketch of undervoltage

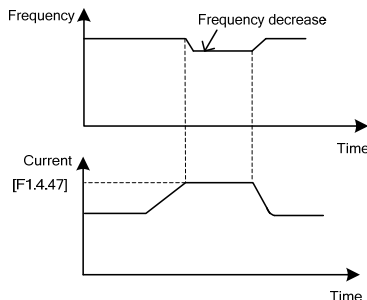

Figure 7-32B Sketch of current-limiting adjusting and undervoltage adjusting

<b>F1.4.47 Current limit trip level</b>	<b>Setting range: 20~200%</b>	<b>Factory default: 190</b>
<b>F1.4.48 Current limit trip level gain</b>	<b>Setting range: 0.10~10.00</b>	<b>Factory default: 1.00</b>

When the output current of frequency inverter exceeds [F1.4.47], it may lower output frequency automatically to suppress current from further increasing, to ensure continually safe running. The bigger (F1.4.48) gain is, the stronger current suppression is. Setting value is relevant percentage of rated output current of frequency inverter.

<b>F1.4.49 Number of auto reset attempts</b>	<b>Setting range: 0~5</b>	<b>Factory default: 0</b>
<b>F1.4.50 Time between auto resets</b>	<b>Setting range: 0.2~100.0Sec.</b>	<b>Factory default: 1.0</b>
<b>F1.4.51 Auto reset cycle time</b>	<b>Setting range: 900~3600Sec.</b>	<b>Factory default: 3600</b>

Fault self resetting refers to that when the frequency inverter breaks down, with a period of time, fault self resetting can be operated and recover to run with starting way of speed inspection. When accumulated resetting times exceeds setting value [F1.4.49], self resetting action terminates. When self resetting time [F1.4.49] is set as zero, it means this function is banned.

Recovery waiting time of fault self resetting gets longer with resetting times: waiting time=[F1.4.50] \* already reset times

Each time it passes the set parameter period [F1.4.51], or external forced fault reset, it will automatically eliminate one self resetting record.

<b>F1.4.53 Display coefficient</b>	<b>Setting range: 0.001~60.000</b>	<b>Factory default: 1.000</b>
------------------------------------	------------------------------------	-------------------------------

It is used for correction values of monitoring parameters (d0.0.00, d0.0.01, d0.0.9, d0.0.10), to match with site parameters.

## 7.11 VECTOR RUNNING PARAMETERS (MOTOR 1) (GROUP F2.0)

<b>F2.0.00~F2.0.04 Motor rated parameters</b>	—	<b>Factory default: ☆</b>
---	---	---------------------------

Nameplate parameters of asynchronous motor, for ensure performance control, it must:

- Correctly set nameplate parameters;
- Power level of motor and frequency inverter shall be match with each other, generally motor only can be two levels less or one level more than frequency inverter.

Change the rated power setting (F2.0.00), it may match with later parameters automatically. Please change the settings in order.

Any one of the nameplate parameters changed, frequency inverter can set static identification of motor parameters once automatically. With motor accessed to start running, an additional static identification of parameters will be conducted prior to running (parameter FF.4.43 can shield this function).

<b>F2.0.05 ~ F2.0.09 Motor internal parameters</b>	—	<b>Factory default: ☆</b>
--	---	---------------------------

This group of parameters can be auto updated after parameter identification, generally free of necessity of setting.

<b>F2.0.10 Slip compensation coefficient</b>	<b>Setting range: 0.50~1.50</b>	<b>Factory default: 1.00</b>
--	---------------------------------	------------------------------

Slip compensation coefficient is used for slip frequency calculation, valid with vector control mode. With SVC running, this parameter can be amended to adjust speed for compensation control.

<b>F2.0.24 Z pulse initial angle</b>	<b>Setting range: 0.0~359.9</b>	<b>Factory default: 0.0</b>
--------------------------------------	---------------------------------	-----------------------------

This parameter is valid when Z pulse selection is valid ([F8.0.07] = 1), used for set corresponding mechanical rotating angle of Z pulse position.

<b>F2.0.25 Overload protection setting motor1</b>	<b>Setting range: 50.0~131.0%</b>	<b>Factory default: 110.0</b>
---	-----------------------------------	-------------------------------

With dragging rated current value ( parameter F2.0.02, F2.1.28) of motor, frequency inverter can automatically confirm the heat protection curve of motor. This parameter is used for setting sensitivity of heat relay protection to load motor of frequency inverter. The larger the value is, the lower the sensitivity is. Please set according to the actual load capacity of motor.

When fixed value of this parameter is 131.0%, overload protection function of motor closes.



- When a frequency inverter runs with several motors in parallel, function of heat relay protection of frequency inverter will out of action automatically. In order to protect motor efficiently, it is suggested that installation of heat protection relay in each motor.

## 7.12 PARAMETER MEASUREMENT AND PRE-EXCITATION (GROUP F2.2)

<b>F2.2.52 Excitation time for vector mode</b>	<b>Setting range: 0.02~2.50Sec.</b>	<b>Factory default: ☆</b>
--	-------------------------------------	---------------------------

This parameter is valid with vector operation; the pre-excitation action must be conducted prior to start of motor, to build air gap flux to obtain enough starting torque. This excitation process shall be conducted after action defined of parameter F0.4.42, excitation current shall be calculated automatically as selected time. The shorter the excitation time is, the larger the current is.

<b>F2.2.53 Motor parameter measurement</b>	<b>Setting range: 0, 1, 2, 3</b>	<b>Factory default: 0</b>
--	----------------------------------	---------------------------

Motor parameter measurement function must be started when vector control mode is selected (tens of F0.0.09 is set as 0 or 1).

When this function (when F2.2.53 is set as 1~3) is operated, there will be a identification operation when the frequency inverter is start. After parameter identification is over, F2.2.53 will automatically reset. Obtained motor parameters will be stored in internal storage of frequency inverter, and value of parameter F2.0.05 ~ F2.0.09 will be automatically updated.

Before identification operation, please confirm that:

- Nameplate parameter of motor (F2.0.01~F2.0.04) has been input correctly;
- The motor is in stopped condition.

### 0: Closed

#### 1: Static identification

During the process of parameter measurement, motor shall be kept in stopped condition. There is no requirement for the connection relationship of motor shaft, but with lower measurement precision.

#### 2: Static + operating parameter identification

Frequency inverter will conduct static identification previously, and then automatically start operation identification process. During operation identification process, stop order can be input to forcedly terminate identification process. It won't be eliminated of application of identification then. When restarted, identification process will be operated again.

Top operating frequency of operation identification will reach 80% of rated frequency of motor. Before identification starts, please be sure to confirm the equipment safety, and it will automatically stop operating when identification ends.

Operation identification can obtain accurate parameters, but it must be operated when the motor is complete no-load. Otherwise, unpredictable parameter value may be obtained.

#### 3: Static + operating parameter identification + revolution ratio identification

Operation process under this setting is totally the same as that of 2, as well as identification result of motor parameters. However, when there's no installation of PG encoder on the motor shaft, the transfer ratio of motor shaft and speed measurement shaft must be obtained to realize closed loop vector control. This setting will not only automatically identify motor parameters, but also will measure the transfer ratio of motor shaft: speed measurement shaft, and result can be stored automatically in parameter F8.0.17.



- During the process of operation identification of motor parameter, it must sure that no load of motor during the whole process, otherwise, incorrect motor parameters will be obtained.

## 7.13 MULTIFUNCTIONAL INPUT TERMINAL (GROUP F3.0)

<b>F3.0.00~F3.0.05 Multifunctional input terminals DI1~DI6</b>	<b>Setting range: 0~96</b>	—
<b>F3.0.06 Multifunctional input terminal DI7/ standard expansion card</b>	<b>Setting range: 0~96</b>	<b>Factory default: 0</b>
<b>F3.0.07 Multifunctional input terminal DI8/ standard expansion card</b>	<b>Setting range: 0~96</b>	<b>Factory default: 0</b>
<b>F3.0.08 Multifunctional input terminal DI9/Fin/standard expansion card</b>	<b>Setting range: 0~98</b>	<b>Factory default: 97</b>

Control terminals **DI1~DI9/Fin** are functional programmable switch input terminals; They can define the **DI1~DI9/Fin** functions respectively by way of the setup of **F3.0.00~F3.0.08** values; See their set values and relevant functions as Table 1 (Contrast Table of Multifunctional Terminals (DI/EDI/SDI) Function).

For example: Define **F3.0.00** as **23**, so the function of DI1 can be defined as "Simple **PLC** Multi-stage Operation Input"; When the DI1 terminal status validates, simple **PLC** multi-stage operation input function can be realized.

The function specifications in the table as following:

### 1~4: Multi-speed control terminals 1~4

By means of the **ON/OFF** status combinations of these four functional terminals, select the set frequencies relevant to **F6.0.00~F6.0.15** parameters as the current set frequencies of frequency converter. The priority of the frequency instruction is higher than frequency set channel **F0.1.16**.

**Table 7-3 Multi-speed operation selection table**

Multi-speed control 4	Multi-speed control 3	Multi-speed control 2	Multi-speed control 1	Frequency set
OFF	OFF	OFF	OFF	Ordinary operation frequency (F0.1.16 determined)
OFF	OFF	OFF	ON	Multi-stage operation frequency 1
OFF	OFF	ON	OFF	Multi-stage operation frequency 2
OFF	OFF	ON	ON	Multi-stage operation frequency 3
OFF	ON	OFF	OFF	Multi-stage operation frequency 4
OFF	ON	OFF	ON	Multi-stage operation frequency 5
OFF	ON	ON	OFF	Multi-stage operation frequency 6
OFF	ON	ON	ON	Multi-stage operation frequency 7
ON	OFF	OFF	OFF	Multi-stage operation frequency 8
ON	OFF	OFF	ON	Multi-stage operation frequency 9
ON	OFF	ON	OFF	Multi-stage operation frequency 10
ON	OFF	ON	ON	Multi-stage operation frequency 11
ON	ON	OFF	OFF	Multi-stage operation frequency 12
ON	ON	OFF	ON	Multi-stage operation frequency 13
ON	ON	ON	OFF	Multi-stage operation frequency 14
ON	ON	ON	ON	Multi-stage operation frequency 15

**5~6: External forward/Reverse jog control**

Apply to jog operation control under the external terminal control (regard **F0.3.33/F0.3.34** as 1).

**7~8: FWD/ REV running command terminal**

Apply to forward (FWD)/reverse (REV) running command under the external terminal control (regard **F0.3.33/F0.3.34** as 1); According to the setup of **F0.3.35**, it can jog two-line mode and three-line mode (regard another external control terminal as three-line running command function (Function No.19)).

**9~10: Acceleration and deceleration time 1 and 2**

By means of the acceleration and deceleration time, selecting the **ON/OFF** status combinations of terminals can realize the selection of acceleration and deceleration time 1~4 (refer to parameter specifications of **F1.0.03~F1.0.10**). If the user doesn't define this function, frequency inverter can automatically select acceleration and deceleration 1, except simple **PLC** jog. See the acceleration and deceleration time selection as following table.

**Table 7-4 Contrast table of acceleration and deceleration time selection**

Acceleration and deceleration time selection 2	Acceleration and deceleration time selection 1	Acceleration and deceleration time
OFF	OFF	Acceleration time 1/Deceleration time 1
OFF	ON	Acceleration time 2/Deceleration time 2
ON	OFF	Acceleration time 3/Deceleration time 3
ON	ON	Acceleration time 4/Deceleration time 4

**11: Running command switching**

This function is applied to switch running command of frequency inverter between control command 1 and control command 2. See the running command switching status as following table:

**Table 7-5 Contrast table of jog command switching**

Terminal status	Running command of frequency inverter
ON	Running command 2
OFF	Running command 1

**12: Frequency command switching**

This function is applied to switch frequency setting source of frequency inverter between frequency setting source 1 and frequency setting source 2. See the frequency command switching status as following table:

**Table 7-6 Contrast table of frequency command switching**

Terminal status	Frequency setting source of frequency inverter
ON	Frequency setting source 2
OFF	Frequency setting source 1

**13: Fault resetting input (RESET)**

Once frequency inverter occurs to fault alarm, reset it through external terminals and be valid to input rising edge; the function is coincident to operation board's **STOP/RESET** buttons'.

**14: Emergency stop (EMS)**

Whatever status frequency inverter operates, if the functional terminal is effective, frequency inverter stops in



terms of set emergency stop mode (F0.4.54) and starts to operate with rising edge of running command.

#### 15~16: Frequency or Process PID set value ascending (UP)/descending (DW)

V560 frequency inverter can achieve the setup of operation frequency via external terminal and long-distance frequency set operation. If the terminal is effective, set frequency increases progressively or decreases progressively in the light of set speed; if the terminal is ineffective, set frequency keeps same. If both terminals are effective, set frequencies keep same. See 4~8 parameter functional specifications of F0.2.25 or F0.2.26.

#### 17: UP/DW set frequency zero clearing

Set frequency of external terminal can be cleared to zero through the functional terminal (set frequencies of frequency increasing progressively command UP/decreasing progressively command DW). The function invalidates frequencies set by other frequencies setting modes.

#### 18: External equipment fault

Inputting external equipment fault signal through the terminal is easy for frequency inverter to fault supervision and communication to external equipment. Since frequency converter receives external equipment fault, displaying "Fu.017" is the external equipment fault and making a stop forcefully.

#### 19: Three wire running control

When select the three-line running mode under the external terminal control (regard F0.3.33/F0.3.34 as 1), define three wire running control for input terminal. See Three wire Mode Introduction (regard F0.3.35 as 2 or 3).

#### 20: Stop DC braking command

When frequency inverter is in the process of deceleration stop and running frequency is lower to straight flow brake or brake starting frequency or speed, the function is effective. When the terminal status is effective, execute DC brake; Only when the terminal status is ineffective, DC brake can be stopped. When operate this function, DC braking functional time F0.4.46 is ineffective.

#### 21: Acceleration and deceleration forbidden

When the terminal is effective, suspend acceleration and deceleration forbidden and frequency inverter keeps current frequency operation as the acceleration and deceleration achieves; if the terminal is ineffective, execute ordinary acceleration and deceleration command.

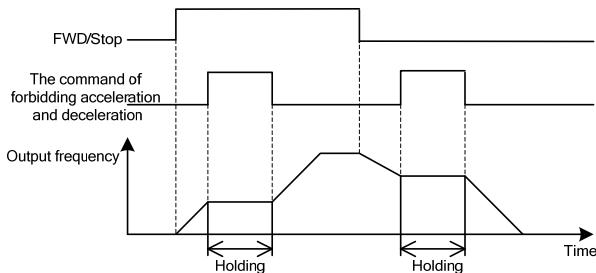

Figure 7-33 Sketch of acceleration and deceleration forbidden

#### 22: Process PID effective

When selecting the multifunctional input terminals in the process PID, the function can achieve process PID's input and cutting off.

#### 23: Simple PLC multi-stage running effective

When select the multi-stage frequencies or rotation running condition input in the programmable multi-stage speed operation mode (regard F6.1.15 as ###2), the functional terminal can achieve simple PLC multi-stage running's input and cutting off.

**24: Swing frequency running effective**

If swing frequency running selects effective terminal (set F6.2.46 as ###2), the functional terminal can input and cut off swing frequency running.

If terminal status is effective, frequency converter runs swing frequency. If terminal status is ineffective, frequency inverter can accelerate and decelerate into swing frequency preset frequency [F6.2.47] for running according to effective acceleration and deceleration time (regard acquiescent value as acceleration and deceleration time 1).

**25: Compensation PID effective**

When the function of compensation PID is activated from external effective terminal selection (regard F9.0.00 as \_\_2), the functional terminal can input and cut off the function of compensation PID.

**26: Simple PLC multi-stage running status (when stopping) resetting**

Simple PLC multi-stage running status when stopping can select the automatic memorized ([F6.1.15] = \_ 1\_ / \_ 2\_). The functional terminal can reset the automatic memorized status forcefully.

**27: Swing frequency status resetting (effective when stopping)**

If the swing frequency's current running status is ([F6.2.46] = \_ 0\_) when swing frequency operation selects automatic memory stop, the functional terminal can reset the status of swing frequency forcefully.

**28~30: Process PID multi-stage given terminals 1~3**

Using ON/OFF status combinations of multi-stage process PID given terminals 1~3 can achieve multi-stage process PID given terminals selection as following table.

**Table 7-7 Contrast table of multi-stage process PID given terminals selection**

Multi-stage process PID given terminal 3	Multi-stage process PID given terminal 2	Multi-stage process PID given terminal 1	Process PID multi-stage given selection
OFF	OFF	OFF	Ordinary process PID given (determined by F7.0.01)
OFF	OFF	ON	Process PID multi-stage given 1
OFF	ON	OFF	Process PID multi-stage given 2
OFF	ON	ON	Process PID multi-stage given 3
ON	OFF	OFF	Process PID multi-stage given 4
ON	OFF	ON	Process PID multi-stage given 5
ON	ON	OFF	Process PID multi-stage given 6
ON	ON	ON	Process PID multi-stage given 7

**31: Process PID setting selection (switching)**

The functional terminal is applied to switch process PID setting of frequency inverter between process PID setting 1 and process PID setting 2. See process PID setting switching status as following table:

**Table 7-8 Contrast table of process PID setting switching status**

Terminal status	Process PID setting of frequency inverter
ON	Process PID setting 2
OFF	Process PID setting 1

**32: Process PID feedback selection (switching)**

This functional terminal is applied to switch Process PID feedback of frequency inverter between process PID setting 1 and process PID setting 2. See process PID switching status as following table:

**Table 7-9 Contrast table of process PID feedback switching status**

Terminal status	Process PID feedback of frequency inverter
ON	Process PID feedback 2
OFF	Process PID feedback 1

**33: Process PID sleep activation**

When the sleep function is activated by multifunctional input terminals (set F7.2.34 as 2), the functional terminal can activate process PID sleep function.

**34: Torque/speed control mode switching**

The functional terminal is applied to switch closed loop control mode of frequency inverter between torque control and speed control. See the closed loop control mode of frequency inverter as following table:

**Table 7-10 contrast table of closed loop control mode of frequency inverter**

Terminal status	Closed loop control mode of frequency inverter
ON	Torque control mode
OFF	Speed control mode

**35: Minimum torque limiting set value selection**

This function is applied to switch minimum torque limiting set value of frequency inverter (negative torque limiting) between minimum torque limiting 1 and minimum torque limiting 2. See switching status as following table:

**Table 7-11 Minimum torque limiting selection contrast table of frequency inverter**

Terminal status	Minimum torque limiting set value of frequency inverter
ON	Minimum torque limiting 2
OFF	Minimum torque limiting 1

**36: Maximum torque limiting set value selection**

This function is applied to switch maximum torque limiting set value of frequency inverter between maximum torque limiting 1 and maximum torque limiting 2. See switching status as following table:

**Table 7-12 Maximum torque limiting selection contrast table of frequency inverter**

Terminal status	Maximum torque limiting set value of frequency inverter
ON	Maximum torque limiting 2
OFF	Maximum torque limiting 1

**40: RS485 external/Standard operation panel switching**

When two operation panels are inserted to frequency inverter at the same time, one is for master control panel switching, and the other is only for monitoring, and the order cannot be inputted in.

**Table 7-13 Control command channel switching and selecting table for frequency inverter**

Terminal state	Control command channel of frequency inverter
ON	RS485 external panel
OFF	Standard operation panel

**42: Start permission**

When parameter F0.4.37 is set as ###1 or ###2, the function terminal is valid.

**43: Running permission**

When parameter F0.4.37 is set as #1## or #2##, the function terminal is valid.

**44~45: Counter clock terminal**

This function terminal is used for counter clock inputting.

**46~47: Counter trigger signal**

This terminal is used as counter trigger end.

**48~49: Counter resetting terminal**

This terminal is used for counter resetting signal inputting.

**50~51: Counter auto control signal**

This terminal is used for counter gated signal inputting.

**52~54: Timer trigger signal**

This terminal is used as timer trigger end.

**55~57: Timer resetting**

This terminal is used for timer resetting signal inputting.

**58~60: Timer gated signal**

This terminal is used for timer gated signal inputting.

**61: Single pulse accumulative length value**

This terminal is used for single pulse accumulative length value resetting.

**62: Motor temperature detection contact input**

When thermo switch is used as the external temperature transmitter (see parameter F5.4.43 specification), this terminal is used for external thermo switch inputting.

**63~64: Compensation PID parameter selection**

When [F9.1.21] = ## 3 3, this terminal is used for controller parameter of compensation PID selecting.

**Table 7-14 Parameter selecting table for compensation PID**

Compensation PID parameter selection 2	Compensation PID parameter selection 1	PID effective parameter group
OFF	OFF	Group 1 (F9.0.03~F9.0.07)
OFF	ON	Group 2 (F9.1.29~F9.1.33)
ON	OFF	Group 3 ( F9.1.34~F9.1.38)
ON	ON	Group 4 (F9.1.39~F9.1.43)

**65: Magnetic flux brake effective**

It is applied to magnetic flux brake function input and removal during the deceleration halt process.

**66: Position pulse counting resetting**

Adjust the position pulse counting to zero, which is used for position origin preset default counting.

**67: Automatic shifting jog**

It is the machinery shifting dedicated function of the spindle or machinery variable speed gear. When this function is invalid, frequency drive system will operate both sides alternatively at certain period or revolving speed/moment of force so as to achieve the machinery shifting, avoiding the dead( relative function parameter: Fb.2.18, Fb.2.19).

**68: Servo pulse command direction**

This function is valid when pulse input port (DI9//Fin) is used as servo command pulse, and representative pulse direction is: invalid is positive (add plus), valid is negative (minus pulse).

**69: Servo control effective**

Switching terminal of servo control and moment of force control (relative function parameter Fb.2.23).

**70: Spindle positioning origin photoelectric signal input**

When reference signal of spindle positioning origin is photoelectric switch positioning (parameter Fb.2.36), this signal stands for spindle origin.

**71: Spindle origin homing**

When this function is valid, spindle auto positions to origin position to maintain the moment of force, and after the signal is cancelled, there is no moment of force output.

**72: Spindle positioning selection 1****73: Spindle positioning selection 2****74: Spindle positioning selection 3**

When the spindle positioning command selects external terminal selecting source(relative function parameter Fb.2.36), these multi-function terminal are used for spindle positioning angle selecting, when the following groups are valid, the spindle positions to the assigned angle and maintains the moment of force. When these terminals are invalid, there is no moment of force output.

**Table 7-15 Selecting table for spindle positioning angle**

Spindle positioning selection 3	Spindle positioning selection 2	Spindle positioning selection 1	Positioning angle values
OFF	OFF	OFF	Common operation
OFF	OFF	ON	Positioning angle 1 (Fb.2.38)
OFF	ON	OFF	Positioning angle 2 (Fb.2.39)
OFF	ON	ON	Positioning angle 3 (Fb.2.40)
ON	OFF	OFF	Positioning angle 4 (Fb.2.41)
ON	OFF	ON	Positioning angle 5 (Fb.2.42)
ON	ON	OFF	Positioning angle 6 (Fb.2.43)
ON	ON	ON	Positioning angle 7 (Fb.2.44)

**75: Position gain selection**

Position gain of servo control or spindle positioning selecting.

**76: Reserved****77: Servo command pulse value zero clearing****78~96: Reservation function****97: Pulse input (0.1~100.00 KHz)**

This function is applied to multi-function input terminal DI9/Fin (F3.0.08), and 0.1~100.00 KHz signal can be received effectively.

**98: Pulse input**

This function is applied to multi-function input terminal DI9/Fin (F3.0.08) and 1.0~1000.0 KHz low frequency signal can be received effectively.

<b>F3.0.09 Multifunctional terminal filtering time (DI1~DI5)</b>	<b>Setting range: 1~50ms</b>	<b>Factory default: 5</b>
<b>F3.0.10 Multifunctional terminal filtering time (DI6~DI9) /standard expansion card</b>	<b>Setting range: 1~50ms</b>	<b>Factory default: 5</b>

Set the filtering time of the input terminal detection. When state of the input terminal changes, if it remains the

same even after the filtering time setting, the terminal state change is effective, or otherwise it will remain the former state, thus the interference triggered false operation can be reduced.

<b>F3.0.11 Input terminal effective level (H)</b>	<b>Setting range: 0000~0FFF</b>	<b>Factory default: 0000</b>
---	---------------------------------	------------------------------

Define the positive and negative logic of the input terminal.

Positive logic: When Dlx terminal and common port COM are connected, it is valid, or otherwise it is invalid.

Negative logic: When Dlx terminal and common port COM are disconnected, it is valid, or otherwise it is invalid.

Bit place as 0 represents the positive logic; 1 represents negative logic.

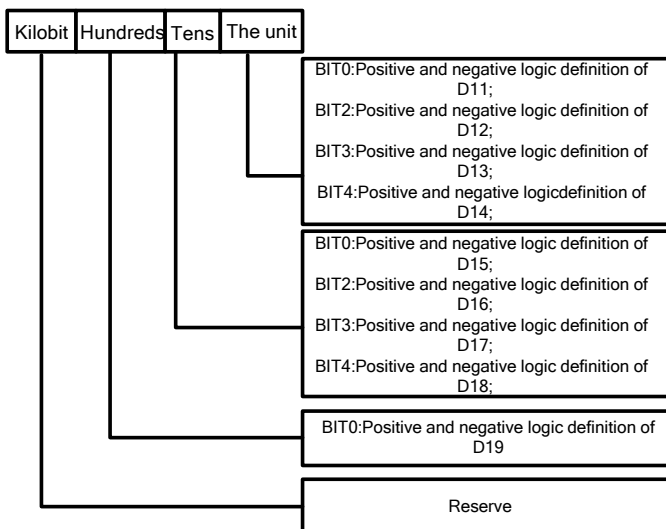

Determination methods of parameter setting value are shown as following:

**Table 7-16 Correspondence between Binary Number Setting and Digital Show Value**

Binary number setting				Hexadecimal(digital show value)
BIT3	BIT2	BIT1	BIT0	
0	0	0	0	0
0	0	0	1	1
0	0	1	0	2
0	0	1	1	3
0	1	0	0	4
0	1	0	1	5
0	1	1	0	6

Binary number setting				Hexadecimal(digital show value)
BIT3	BIT2	BIT1	BIT0	
0	1	1	1	7
1	0	0	0	8
1	0	0	1	9
1	0	1	0	A
1	0	1	1	b
1	1	0	0	C
1	1	0	1	d
1	1	1	0	E
1	1	1	1	F

## 7.14 MULTIFUNCTIONAL OUTPUT TERMINAL (GROUP F3.1)

<b>F3.1.12 Multifunctional output DO1</b>	<b>Setting range: 0~71</b>	<b>Factory default: 1</b>
<b>F3.1.13 Multifunctional output DO2</b>	<b>Setting range: 0~71</b>	<b>Factory default: 2</b>
<b>F3.1.14 Multifunctional output DO3/ Fout/standard expansion card</b>	<b>Setting range: 0~71</b>	<b>Factory default: 63</b>
<b>F3.1.21 Multifunctional relay output (RO1A/B/C)</b>	<b>Setting range: 0~71</b>	<b>Factory default: 4</b>
<b>F3.1.22 Multifunctional relay output (RO2A/B/C)/standard expansion card</b>	<b>Setting range: 0~71</b>	<b>Factory default: 5</b>

The control terminal D01-D03 is the on-off output terminal with programmable function, and its functions can be defined by set values of F3.1.12-F3.1.14; Functions of output RO1and RO2 of relay, on-off output terminal with programmable function, can be defined by set values of F3.1.21 and F3.1.22. Please refer to the attached list for their set values and corresponding functions (Reference table of variables of multi-function output terminal (DO/EDO/SDO)).

### 1: Inverter running ready

When inverter is in normal running ready state, terminal will output effective signal/relay will pull in (connection of TA and TC).

### 2: Inverter is running

When inverter is in running state, terminal will output effective signal/relay will pull in.

### 3: Equipment normal

When inverter is fault free, and DC busbar voltage is normal, terminal will effectively indicate signal/relay will pull in.

### 4: Equipment fault

When inverter goes wrong and sends fault signal, terminal will output effective signal/relay will pull in.

### 5: Equipment alarm

When there is exception of inverter and sending warning signal, terminal will output effective signal/relay will

pull in.

#### **6: Equipment fault or alarm**

When there is fault for exception of inverter and sending fault or warning signal, terminal will output effective signal/relay will pull in.

#### **7: Reverse running**

When electric motor rotates reversely, the terminal will output the valid signal/relay will pull in.

#### **8: Running command valid**

When running instruction of inverter is valid, the terminal will output the valid signal/relay will operate.

#### **9: Running at zero speed**

When running instruction is valid but output frequency of inverter is at zero and there is current output, terminal will output effective signal/relay will pull in.

#### **10: Speed not at zero**

When the speed of rotator of electric motor is not at zero (VC mode) or output frequency is not at zero (VF or SVC mode), terminal will output the valid signal/relay will pull in.

#### **11: Inverter undervoltage stop**

When inverter is in under-voltage stop and reporting Fu.008, the terminal will output the valid signal/relay will pull in.

#### **12: Terminal control effective**

When control command of frequency converter is given not on panel, terminal will output the valid signal/relay will pull in.

#### **14: Running at power generating status (braking)**

When inverter is in regenerative braking running state, terminal will output the valid signal/relay will pull in.

#### **19: Completion of current stage of multi-stage running (0.5s pulse)**

After completion of current stage of multi-stage running, terminal will output the valid pulse signal with 0.5s width/relay will disconnect after pulling in for 0.5s.

#### **20: Multi-stage running completed (0.5s pulse)**

After completion of one cycle of multi-stage speed running, terminal will output the valid impulse signal with 0.5s width/relay will disconnect after pulling in for 0.5s.

#### **21: Multi-stage running completed (continuous level output)**

After completion of one cycle of multi-stage speed running, terminal will output continuous valid signal/relay will pull in.

#### **22: Multi-stage running cycle completed (0.5s pulse)**

After completion of one cycle of multi-stage speed running, terminal will output effective impulse signal with 0.5s width/relay will disconnect after pulling in for 0.5s.

#### **23: Swing frequency upper and lower limit**

After selection of wobulation, if the frequency fluctuation range of wobulation, which calculated based on center frequency, is above upper limit frequency F0.1.21 or below lower limit frequency F0.1.22, then terminal will output effective signal/relay will pull in.

#### **24: Encoder direction**

It is used to indicate the directional signal output by current encoder frequency division.

#### **26/29/32: Monitoring parameters 1/2/3 below the lower limit**



When monitoring parameters 1/2/3 are below the lower limit values, terminal will output the valid signal/relay will pull in, which keeps until monitoring parameters 1/2/3 are above the upper limit values, then output the invalid signal/relay disconnects (as shown in Figure 7-34-A).

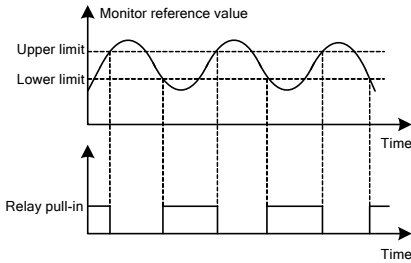

Figure 7-34-A Monitor functional sketch 1

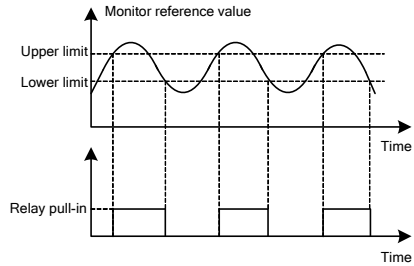

Figure 7-34-B Monitor functional sketch 2

### 27/30/33: Monitoring parameters 1/2/3 above the lower limit

When monitoring parameters 1/2/3 are above the upper limit values, terminal will output effective signal/relay will pull in, which keeps until monitoring parameters 1/2/3 are below the lower limit values, then output ineffective signal/relay disconnects (as shown in Figure 7-34-A)

### 28/31/34: Monitoring parameters 1/2/3 between the upper limit and the lower limit

When monitoring parameters 1/2/3 are between upper and lower limit values (including equal to upper and lower limit values), the terminal will output the indicator signal/relay will pull in.

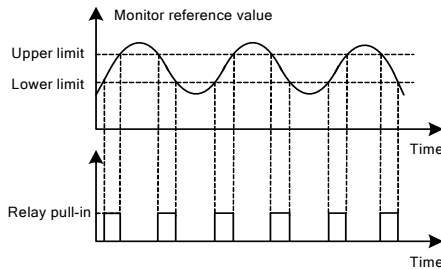

Figure 7-34-C Functional sketch 3 of monitor

### 36~38: Analog input AI1 wire-break detection effective

When inverter detects wire-break of analog input, it will choose to make corresponding operation according to operation after wire-break; Meanwhile terminal will output effective signal/relay will pull in.

### 40~43: Counter output signal

When counting of counter reaches to setting value, terminal will output effective signal/relay will pull in. Please refer to function specifications for F5.2.20~F5.2.27 parameters

### 44~49: Timer output signal

When comparative value /periodic value of timer reaches to setting value, terminal will output effective signal/relay will pull in. Please refer to function specifications for F5.1.06 ~ F5.1.19 parameters

### 55~62: Status of multifunctional input terminal

If D10~D18 terminals are effective, terminal will output effective signal/relay will pull in.

### 63: DO3/Fout terminal as the frequency output terminal

As frequency output terminal, frequency range of signal output by D03/ Fout: 0.07-100.0KHz.

**64~71: Please refer to chapter six “chart2: Variable table of multi-function output terminal (DO/EDO/SDO)”**

<b>F3.1.15~F3.1.20 DO1~DO3 delay time for switching signal output ON and OFF</b>	<b>Setting range: 0.01~10.00Sec.</b>	<b>Factory default: 0.0</b>
<b>F3.1.23~F3.1.26 RO1/RO2 delay time for switching ON/OFF</b>	<b>Setting range: 0.01~10.00Sec.</b>	<b>Factory default: 0.0</b>

This group of parameters are used to define multi-function output terminal DO1~DO3 and time delay of change for signal state output by multi-function relay RO1/RO2. When signal output by multi-function terminal and pulled in by relay is effective, terminal will output indicator signal, and relay will pull in(connection of TA and TC) after delay time set by parameters F3.1.15~F3.1.20, F3.1.23~F3.1.26.

<b>F3.1.27~F3.1.29 Input variables of monitor 1~3</b>	<b>Setting range: 0~44</b>	<b>Factory default: 0~2</b>
---	----------------------------	-----------------------------

Different state parameters can be monitored by setting the values of F3.1.27~F3.1.29.

<b>F3.1.30~F3.1.35 Upper and lower limit of monitor 1~3 variables</b>	<b>Setting range: 0.0~100.0%</b>	<b>Factory default: 0.0/100.0</b>
---	----------------------------------	-----------------------------------

This group of parameters restricts the range of monitoring parameter variables, of which the set values are relative to the percentages of full monitoring variable output.

## 7.15 PULSE INPUT (GROUP F3.2)

<b>F3.2.36 Min pulse input frequency DI9/Fin</b>	<b>Setting range: 0.0~100.00KHz</b>	<b>Factory default: 0.0</b>
<b>F3.2.37 Max pulse input frequency DI9/Fin</b>	<b>Setting range: 0.01~100.00KHz</b>	<b>Factory default: 10.0</b>
<b>F3.2.38 Pulse detection cycle</b>	<b>Setting range: 1~20ms</b>	<b>Factory default: 10</b>

This group of parameters defines multi-function input terminal **DI9/Fin** as frequency range and detection cycle of external pulse signal for pulse input (**F3.0.08** is set as 97-99), effective breadth of external pulse signal is 5-30V.

<b>F3.2.39 Encoder pulse single channel</b>	<b>Setting range: 1~4096</b>	<b>Factory default: 1024</b>
---	------------------------------	------------------------------

When input frequency signal of **DI9/Fin** terminal is used for length accumulation or speed measurement, these parameters are used to set pulse signal quantity for each rotation of encoder.

<b>F3.2.40 Mechanical transmission ratio</b>	<b>Setting range: 0.010~10.000</b>	<b>Factory default: 1.000</b>
<b>F3.2.41 Driving wheel diameter (for liner speed calculation)</b>	<b>Setting range: 0.1~2000.0mm</b>	<b>Factory default: 100.0</b>

This group of parameters is used for linear speed calculation or length accumulation.

Mechanical drive ratio=rotating speed of pulse speed measuring shaft: Rotating speed of motor shaft

<b>F3.2.42</b> Max length count value	<b>Setting range: 10m~50000m</b>	<b>Factory default: 50000</b>
<b>F3.2.43</b> Max liner speed	<b>Setting range: 0.01~500.00</b>	<b>Factory default: 10.00</b>

When reach or exceed limit maximum accumulative length or linear speed, warning signal can be output through multi-function output signal DOx.

<b>F3.2.44</b> Current length count value	<b>Setting range: 0~50000m</b>	<b>Factory default: —</b>
<b>F3.2.45</b> Current liner speed	<b>Setting range: 0.0~500.00</b>	<b>Factory default: —</b>

Parameters in read-only state are used to display calculated results of current length and linear speed.

## 7.16 PULSE OUTPUT (GROUP F3.3)

<b>F3.3.46</b> Type of output pulse signal DO3/Fout	<b>Setting range: 0, 1, 2</b>	<b>Factory default: 0</b>
---	-------------------------------	---------------------------

**0: Frequency signal (0.25-100.00KHz)**

**1: Frequency signal**

**2: Pulse width modulation (PWM) signal**

In setting 2, the fault frequency range is 0.25 ~100.00KHz, modulation frequency is set by maximum pulse with outputting frequency parameter **F3.3.48**, which can be used to expand AO port.

<b>F3.3.47</b> Min pulse output frequency DO3/Fout	<b>Setting range: 0.25~100.00KHz</b>	<b>Factory default: 0.25</b>
<b>F3.3.48</b> Max pulse output frequency DO3/Fout	<b>Setting range: 0.25~100.00KHz</b>	<b>Factory default: 10.0</b>

When this group of parameters define multi-function output terminal **DO3/Fout** as pulse output (Function No. 63), its frequency range of output pulse, category settings of pulse signal output, and output frequency range are different.

<b>F3.3.50</b> Lower of limit DO3/Fout	<b>Setting range: 0.0~[F3.3.51]</b>	<b>Factory default: 0.0</b>
<b>F3.3.51</b> Upper of limit DO3/Fout	<b>Setting range: [F3.3.51]~100.0%</b>	<b>Factory default: 100.0</b>

This group of parameters can determine the corresponding relationship between maximum, minimum frequency and pulse output mapping variables, while the set values are the percentages of full pulse output mapping variables. Corresponding relationship between the two is as shown in Figure 7-35:

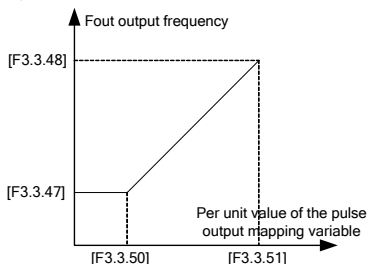

Figure 7-35 Characteristic curve of pulse output fount

## 7.17 ANALOG INPUT (GROUP F4.0)

### F4.0.00~F4.0.05 Minimum and maximum values of analog input AI1~AI3

This group of parameters is used to define the setting range of analog input signal, which need to be set according to actual situation of access signal.

AI1 analog input port is unipolar voltage signal; AI2 analog input port is unipolar current signal; AI3 analog input signal is bipolar voltage signal.

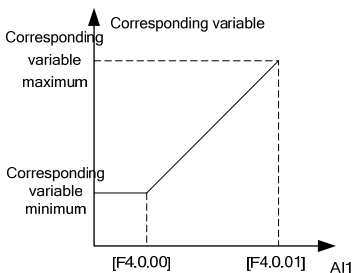

Figure 7-36-A Sketch of AI1 analog input and corresponding variables (unipolarity)

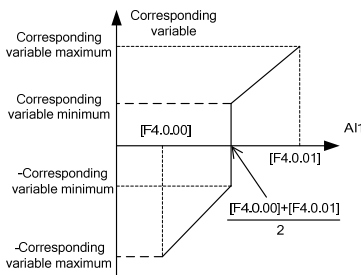

Figure 7-36-B Sketch of AI1 analog input and corresponding variables (biolarity)

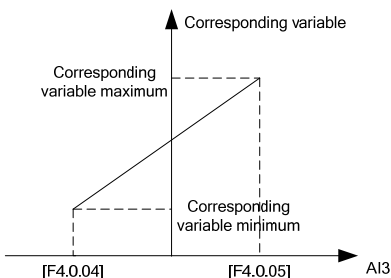

Figure 7-37-A Sketch of AI3 analog input and corresponding variables (unipolarity)

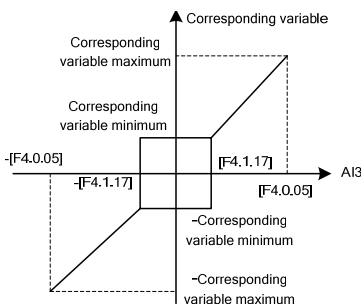

Figure 7-37-B Sketch of AI3 analog input and corresponding variables (bipolarity)



- When the unipolar input signal AI1 and AI2 are applied as bipolar signal, if input signal breaks and input value is maximum reserve setting, it may be dangerous to human and property safety. Please use in combination with broken-line fault detection function of analog input port.

### F4.0.06~F4.0.08 Filtering time constant AI1~AI3

Setting range: 1~1000ms

Factory default: 10

Carry out filtering treatment to external analog input quantity to effectively eliminate interference signal. Filtering time constant (time needed for given signal rising to 63% of stable value) should be set properly according to fluctuation range of external input signal, if set it too high, anti-interference capacity will be strong while delaying the speed of response to setting signal.

## 7.18 ANALOG INPUT CURVE CORRECTION (GROUP F4.1)

<b>F4.1.09~F4.1.21</b> Analog input AI1~AI31 curve correction point/value 1~3	—	—
---	---	---

This group of parameters is used to conduct nonlinear correction to analog input value as required. Curve correction of analog input AI1 is as shown in figure # ##, while the curve correction methods of AI2 and AI3 are similar to analog input AI1.

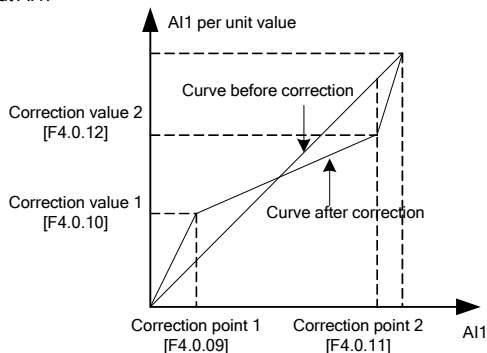

Figure 7-38 Curve correction of analog input AI1

<b>F4.1.17</b> AI3 hysteresis band dead zone	<b>Setting range: 0.00~2.00</b>	<b>Factory default: 0.10</b>
--	---------------------------------	------------------------------

Set hysteresis width of middle point between maximum value and minimum value of AI3, when it is applied as bipolar signal, forward and reverse fluctuation of zero setting value will be frequent as shown in Figure 7-38. It should be set as 0 when applied as unipolar signal.

## 7.19 ANALOG OUTPUT (GROUP F4.2)

<b>F4.2.22</b> AO1 function selection	<b>Setting range: 0~45</b>	<b>Factory default: 0</b>
<b>F4.2.23</b> AO2 function selection/ standard expansion card	<b>Setting range: 0~45</b>	<b>Factory default: 2</b>

Multifunction analog output AO1, AO2 can output voltage signal of 0~10V or current signal of 1~20mA, selected by the dial switch on the control board. Frequency inverter status represented by the analog output signal is set by this group of parameters. Please see Appendix 3 (comparison table of status variable).

<b>F4.2.24</b> AO1 min value	<b>Setting range: 0.00~10.00V</b>	<b>Factory default: 0.0</b>
<b>F4.2.25</b> AO1 maxi value	<b>Setting range: 0.00~10.00V</b>	<b>Factory default: 10.00</b>
<b>F4.2.30</b> AO2 min value/standard expansion card	<b>Setting range: 0.00~10.00V</b>	<b>Factory default: 0.0</b>
<b>F4.2.31</b> AO2 max value/standard expansion card	<b>Setting range: 0.00~10.00V</b>	<b>Factory default: 10.00</b>

This group of parameters defines the maximum and minimum of multifunction analog output AO1, AO2 allowed to output.

<b>F4.2.26 AO1 lower limit scaling</b>	<b>Setting range: 0.0~[F4.2.27]</b>	<b>Factory default: 0.0</b>
<b>F4.2.27 AO1 upper limit scaling</b>	<b>Setting range: [F4.2.26]~100.0%</b>	<b>Factory default: 100.0</b>
<b>F4.2.32 AO2 lower limit scaling /standard expansion card</b>	<b>Setting range: 0.0~[F4.2.33]</b>	<b>Factory default: 0.0</b>
<b>F4.2.33 AO2 upper limit scaling /standard expansion card</b>	<b>Setting range: [F4.2.32]~100.0%</b>	<b>Factory default: 100.0</b>

Corresponding relationship between maximum and minimum of **AO1**, **AO2** output given by this group of parameters and mapping variable (see figure below), whose set value is the percentage relevant to the full output of mapping variable of **AO1**, **AO2**.

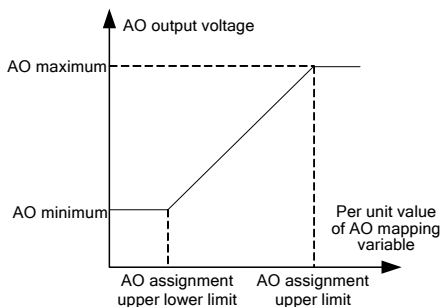

Figure 7-39 AO output characteristic curve

<b>F4.2.28 AO1 filtering time constant</b>	<b>Setting range: 0.01~10.00Sec.</b>	<b>Factory default: 0.10</b>
<b>F4.2.34 AO2 filtering time constant/standard expansion card</b>	<b>Setting range: 0.01~10.00Sec.</b>	<b>Factory default: 0.10</b>

This group of parameters is used to set the filtering time coefficient of **AO1**, **AO2** analog output signal, according to selection of requirements of the rapidity and wave character of signal. The larger the time coefficient is, the smoother the output signal is, and the slower the response is.

<b>F4.2.29 AO1 output signal selection</b>	<b>Setting range: 0.00~20.00mA (0.00~10.00V)</b>	<b>Factory default: 0.0</b>
<b>F4.2.35 AO2 output signal selection/standard expansion card</b>	<b>Setting range: 0.00~20.00mA (0.00~10.00V)</b>	<b>Factory default: 0.0</b>

When the mapping variable of multifunction analog output **AO1**, **AO2** is a fixed value (**F4.02.22**, **F4.2.23** is set as 24), fixed value of **AO1** output is [**F4.2.29**], and the fixed value of **AO2** output is [**F4.2.35**], which can output voltage and current signal.

## 7.20 ANALOG INPUT WIRE-BREAK DETECTION (GROUP F4.3)

On condition that break detection function of analog input is valid, when the value of **A11**, **A12** and **A13** analog input is within the range of detection threshold level, when the frequency inverter passes the action of break detection delay, conduct corresponding action according to the selected setting after the wire-break action.

<b>F4.3.39</b>	<b>Action selection after A11 wire-break</b>	<b>Setting range: 0~4</b>	<b>Factory default: 0</b>
<b>F4.3.43</b>	<b>Action selection after A12 wire-break</b>	<b>Setting range: 0~4</b>	<b>Factory default: 0</b>
<b>F4.3.48</b>	<b>Action selection after A13 wire-break</b>	<b>Setting range: 0~4</b>	<b>Factory default: 0</b>

Define corresponding actions after frequency inverter detects analog input wire-breakage.

### 0: No action (for non-stop alarm)

When detecting analog input wire-break, if the frequency inverter operates normally, it only reports aL.036-aL.038 warning signal. If the wire-break fault is cleared, the warning signal can be cleared automatically.

### 1: Forcedly set to the minimum

When detecting analog input wire-break, if the frequency inverter operates normally, it reports aL.036-aL.038 warning signal. Meanwhile, forcedly set the analog input signal to the minimum of analog input. If the wire-break fault is cleared, the warning signal can be cleared automatically, meanwhile, the analog input signal recovers to input value.

### 2: Forcedly set to the maximum

When detecting analog input wire-break, if the frequency inverter operates normally, it reports aL.036-aL.038 warning signal. Meanwhile, forcedly set the analog input signal to the maximum of analog input. If the wire-break fault is cleared, the warning signal can be cleared automatically, meanwhile, the analog input signal recovers to input value.

### 3: Forcedly set to the default value

When detecting analog input wire-break, if the frequency inverter operates normally, it reports aL.036-aL.038 warning signal. Meanwhile, forcedly set the analog input signal to the default input value of analog input. If the wire-break fault is cleared, the warning signal can be cleared automatically, meanwhile, the analog input signal recovers to input value.

### 4: Inverter forced trip stop

When detecting analog input wire-break, it reports aL.036 - aL.038 fault signal and lock output, and load motor freely sliding down. If the wire-break fault is cleared, fault signal shall be cleared with hand-reset.

## 7.21 HOPPING FREQUENCY (GROUP F5.0)

Hopping frequency function makes the output frequency of frequency inverter to avoid the mechanical resonant frequency point of machine loaded.

Setting frequency of frequency inverter can operate with hopping frequency near some frequency point as the method in the figure below, with 3 hopping ranges defined at most.

After hopping frequency parameters are set, even the setting frequency of frequency inverter is within the mechanical resonant frequency band of driving system; Output frequency of frequency inverter will still adjust out of the mechanical resonant band, operating with lower limiting value of the hopping range of this hopping frequency.

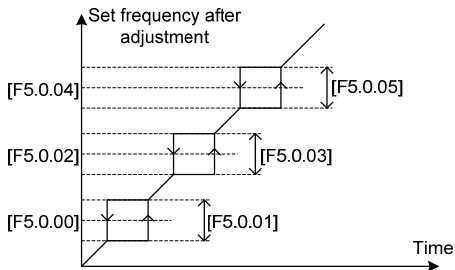

Figure 7-40 Schematic diagram of hopping frequency output

## 7.22 BUILT-IN AUXILIARY TIMER (GROUP F5.1)

This group of parameters is mainly instructed by taking example of timer 1.

### 7.22.1 BASIC FUNCTIONS OF THE TIMER

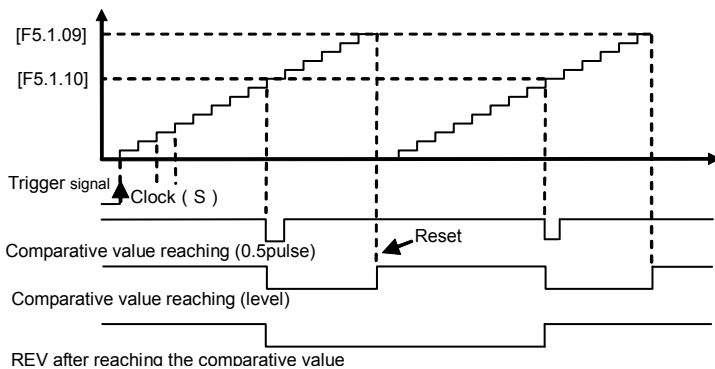

Figure 7-41-A Schematic diagram of comparison value of timer 1 reaching for the basic function (F5.1.06=11#1)



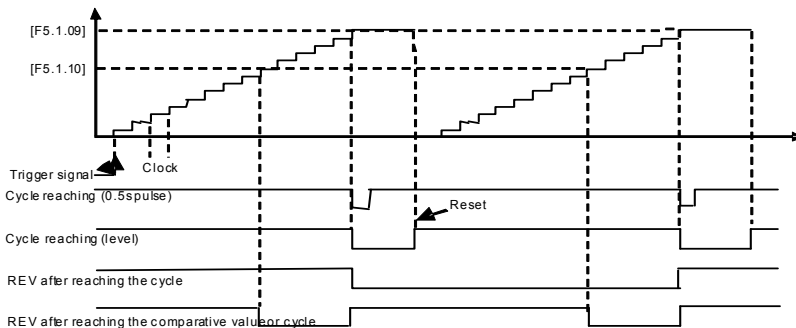

Figure 7-41-B Schematic diagram of comparison value of timer 1 reaching for the basic function (F5.1.06=10#1)

### 7.22.2 TRIGGER AND GATE CONTROL FUNCTION SETTING OF TIMER

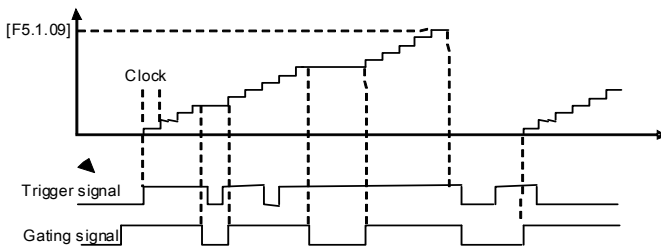

Figure 7-41-C Starting trigger and gate control signal function of timer 1 (UT1) (F5.1.06=1111; F5.1.15=0001)

### 7.22.3 CLOCK CONCATENATION FUNCTION SETTING OF TIMER

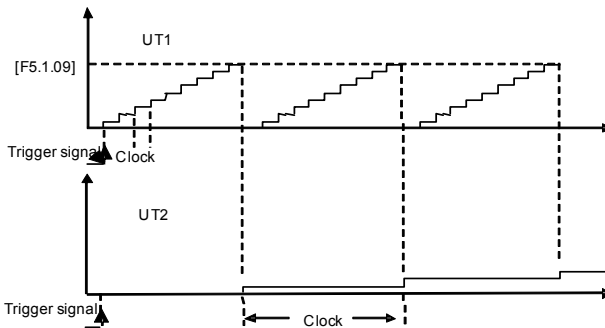

Figure 7-41-D Pulse concatenation function of timer 1(UT1) (F5.1.06=10#1; F5.1.07=###3)

### 7.22.4 CONCATENATION TRIGGER FUNCTION SETTING OF TIMER

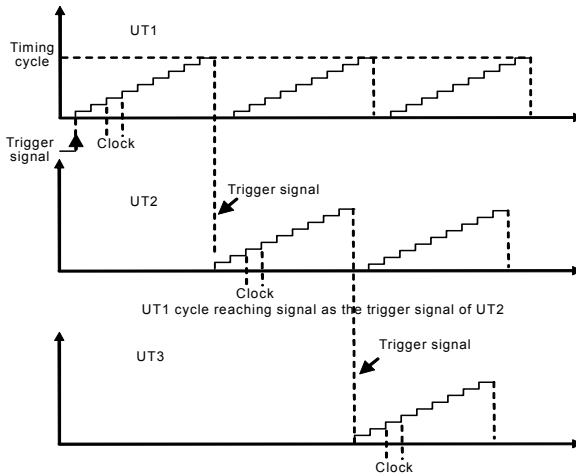

Figure 7-41-E Concatenation trigger function setting of timer (UT1, UT2, UT3)

### 7.23 BUILT-IN AUXILIARY COUNTER (GROUP F5.2)

Similar to the function of timer, the counter is designed for external clock (unknown frequency variable), and timer is designed for the internal clock (known and determined frequency). With the terminal function of analog input output, it can transfer the counter into the function of timer.

Differences: Counter will continue to count upwards without reset, and start from 0 on until overflow.

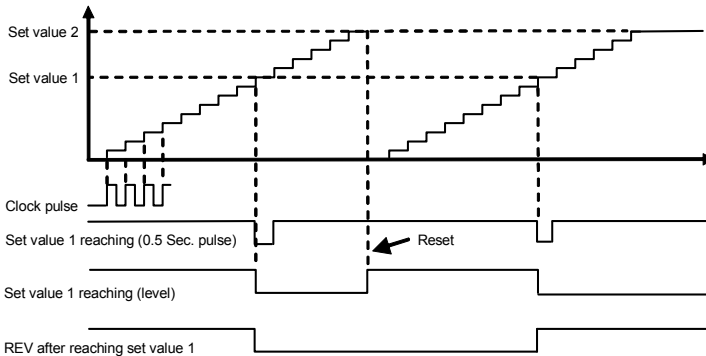

Figure 7-42-A Counter function 1

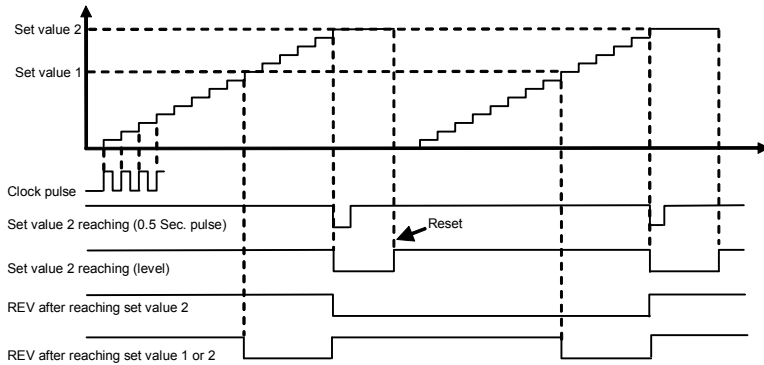

Figure 7-42-B Counter function 2

## 7.24 AUXILIARY FUNCTIONS (GROUP F5.3)

<b>F5.3.28 Priority selection of frequency(revolution) command source</b>	<b>Setting range: 0000~7777</b>	<b>Factory default: 0000</b>
---	---------------------------------	------------------------------

This parameter is used to define the priority order of (revolving speed) instructions source of given frequency. When the setting channel with higher priority is invalid, frequency set value of frequency inverter will automatically set value with the frequency of next top priority.

**Table 7-17 Frequency Setting Order of V560 Frequency Inverter:**

Priority	Setting	Remarks
1	Inching frequency setting	Top priority
2	Torque control method	In case of torque control method, frequency setting is invalid
3	Priority defined by this parameter (four at most)	Priority defined by this parameter shall be deleted from the list of lower priority automatically
4	process PID output	
5	Swing frequency Operating frequency	
6	compensation PID output	
7	Revolving speed setting channel (F8.0.00)	
8	Automatic multiple frequency operating order	
9	Multiple operating frequency of external terminal selection	
10	Frequency setting channel (F0.1.16)	Lowest priority

<b>F5.3.29 Lower limiting frequency action mode</b>	<b>Setting range: 0, 1</b>	<b>Factory default: 0</b>
---	----------------------------	---------------------------

**0: Output zero frequency when it is below the lower limiting frequency**

If the value is less than the lower limiting frequency, the output of the inverter frequency is zero.

**1: Output the lower limiting frequency when it is below the lower limiting frequency**

If the value is less than the lower limiting frequency, the output of the inverter frequency is the lower limiting frequency.

<b>F5.3.30 Automatic voltage regulation(only effective in V/F mode)</b>	<b>Setting range: 0, 1, 2</b>	<b>Factory default: 0</b>
---	-------------------------------	---------------------------

This parameter applies to the situation that frequency inverter operates with **V/F** mode, forcedly operate with VC, SVC modes. Automatic voltage regulation function is used for ensuring the output voltage of frequency inverter not fluctuate as the input voltage fluctuates. In condition that grid voltage fluctuates greatly, while stable stator voltage and current of motor is required, this function shall be operated.

<b>F5.3.31 Energy saving mode (only effective for asynchronous motors)</b>	<b>Setting range: 0, 1</b>	<b>Factory default: 0</b>
--	----------------------------	---------------------------

Magnetic flux operates optimally, and valid with asynchronous machine. Automatic energy saving operation refers to frequency inverter can detect the load condition of motor automatically, and adjust output voltage timely to make the motor operate at high efficient status, to reach optimal effect of energy saving.

Automatic energy saving operation has the best effect when the load change of motor is with low frequency and wide range. The major energy saving way is to obtain additional energy saving effect from adjusting the status of motor excitation, to make the motor operate at optimal high efficient status, and greatly lower the energy consumption of motor.

Due to the specific corresponding relationship of draught fan, pump load and revolving speed, load condition can be judged according to the output frequency. It is a typical special case of automatic energy saving operation applying drop torque V/F curve. When applying drop torque **V/F** curve (**F1.2.17**, **F1.3.29** selection as 1, 2, 3), without necessary of operating the automatic energy saving operation function.

<b>F5.3.32 DC injection braking</b>	<b>Setting range: 0, 1, 2</b>	<b>Factory default: 0</b>
-------------------------------------	-------------------------------	---------------------------

Frequency inverter can increase the magnetic flux when the motor slows down to stop, to make the motor stops more rapidly (see figure below).

The electric energy produced during the braking process is mainly consumed in form of heat inside of the motor. Therefore, frequent braking with magnetic flux will lead to the internal temperature of the motor increase. Please be sure the motor temperature shall not over the maximum admissible value.

When input operation order during magnetic flux braking, magnetic flux will be canceled, and frequency inverter will speed up again to the selected frequency. When applying braking resistor, generally the magnetic flux braking shall be selected as invalid or lower the strength properly (**F5.3.33**).

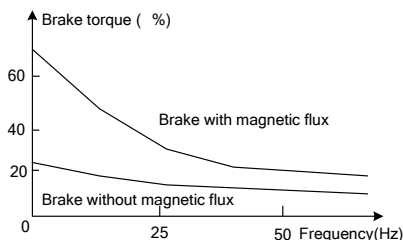

Figure 7-43  
Magnetic flux braking curve

<b>F5.3.33 DC injection braking intensity</b>	<b>Setting range: 30~120%</b>	<b>Factory default: ☆</b>
---	-------------------------------	---------------------------

This parameter defines the increased amplitude of motor magnetic flow when magnetic flow braking, selected value is the relevant percentage of rated magnetic flow.

<b>F5.3.34 Voltage over modulation</b>	<b>Setting range: 0, 1</b>	<b>Factory default: 1</b>
--	----------------------------	---------------------------

Voltage over modulation refers to that in condition of lasting low grid voltage or lasting heavy load operation, frequency inverter improve the output voltage with improving the utilization rate of its bus voltage. When over modulation function is valid, output current harmonic will increase slightly.

**0: Void**

**1: Effective**

<b>F5.3.35 Use ratio of dynamic braking</b>	<b>Setting range: 50~100%</b>	<b>Factory default: 100</b>
---	-------------------------------	-----------------------------

<b>F5.3.36 Level of dynamic braking starting action</b>	<b>Setting range: 700~760V</b>	<b>Factory default: 720</b>
---	--------------------------------	-----------------------------

These two parameters is valid to frequency inverters with built-in braking unit (22KW and models below), used to define action parameters of built-in braking unit of frequency inverters. When the voltage at internal direct current side of frequency inverter is higher than starting action level of dynamic braking [F5.3.36], build in braking unit action. If there is external braking resistor, it shall make the direct current voltage fall back, via releasing pumped-up voltage energy with braking resistor. When the voltage at DC side drops down to a specific value, the built-in braking unit of the frequency inverter closes, as shown in Figure 7-44.

Utilization rate of dynamic braking is used to define the average voltage value forced on braking resistor of braking unit action. Voltage on braking resistor is pulse width modulation wave. Duty ratio equals to action ratio of dynamic braking. The large the action ratio is, the faster energy releases, and the more obvious the effect is, as well as the larger power consumed on braking resistor is. Operator may consider setting the parameters comprehensively according to the resistance of braking resistor, power and required braking effect.

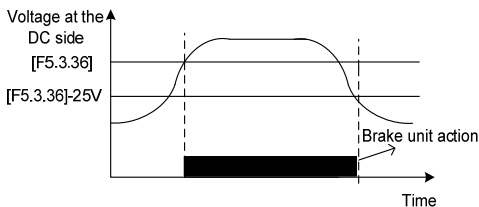

Figure 7-44 Dynamic braking

<b>F5.3.37 Vibration suppression coefficient</b>	<b>Setting range: 0.0; 0.1~10.00</b>	<b>Factory default: 0.0</b>
--	--------------------------------------	-----------------------------

Only valid with V/F control method. Selecting this parameter can restrain the output current oscillation.

Setting 0.0 to close this function. The larger the value is, the slower restraining action is and the wider the biggest adjustment range is.

<b>F5.3.38 Load balancing feature</b>	<b>Setting range: 0, 1, 2</b>	<b>Factory default:0</b>
---------------------------------------	-------------------------------	--------------------------

<b>F5.3.39 Load balancing reference</b>	<b>Setting range: 0~5</b>	<b>Factory default:0</b>
---	---------------------------	--------------------------

<b>F5.3.40 Reference value for load balance load</b>	<b>Setting range: 0.0~200.0%</b>	<b>Factory default:100.0</b>
--	----------------------------------	------------------------------

<b>F5.3.41 Load balancing adjustment gain</b>	<b>Setting range: 0.0~100.00</b>	<b>Factory default:50.00</b>
<b>F5.3.42 Load balancing adjustment limit</b>	<b>Setting range:0.00~100.00(%)</b>	<b>Factory default:1.00</b>

Load dynamic balance function is used for balancing load with multiple motors linkage, or occasions requiring torque motor characteristics of "Frequency inverter-asynchronous electrical units".

When this function is valid, frequency inverter shall take the input value of dynamic balance load reference source (relative value of rated current) as reference, automatically amend the input of frequency/revolving speed integrator, adjusting output frequency to balance the load. The adjustment to output frequency for dynamic balance function is relatively slow, and influenced by selections of acceleration and deceleration time.

If rapid response of linkage balance operation is required, please apply with linkage operation self-balancing function (referring to instruction of parameters in FA group), or applying with compensation PID to build flexibly as necessary, which can conduct adjustment directly to the output of frequency integrator.

Adjusting gain value = [F5.3.41]\*rated current of equipment/100, when the difference of output current and reference value reaches the adjusting gain value, output frequency will drop to the adjusting amplitude limit value.

Adjusting amplitude limit value = [F5.3.42]\*current selected frequency/100, this value is the amplitude peak of dynamic balance adjustment.

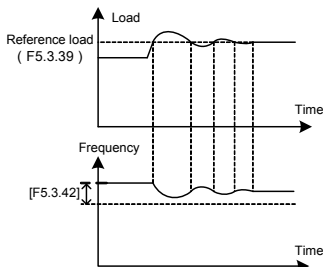

Figure 7-45 Sketch of load dynamic balance function

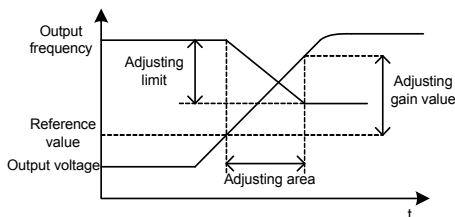

Figure 7-46 Sketch of dynamic balance variables

## 7.25 MOTOR TEMPERATURE DETECTION (GROUP F5.4)

<b>F5.4.43 Type 2 of motor temperature sensor</b>	<b>Setting range: 0~6</b>	<b>Factory default: 0</b>
---	---------------------------	---------------------------

This parameter is referred to types of the selected motor temperature sensor; the different selected motor temperatures sensor with different internal algorithms results in corresponding changes in units of **F5.4.46** and **F5.4.47**: When the sensor is the thermoswitch/PT100, their units are °C; When the sensor is PTC, their units are Ω

- |  |  |
|--|--|
| <b>0: None</b>                         | <b>1: 1 X PT100</b>                      |
| <b>2: 2 X PT100</b>                    | <b>3: 3 X PT100</b>                      |
| <b>4: PTC sensor</b>                   | <b>5: Thermoswitch (normally closed)</b> |
| <b>6: Thermoswitch (normally open)</b> |  |

The motor temperature can be measured by connecting the PT100 or PTC sensor to the analog input and output interfaces of frequency converter. See Figure 7-47-A and Figure 7-47-B for wiring:

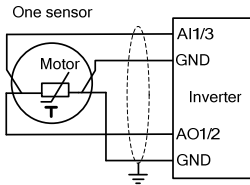

Figure 7-47-A Motor temperature measurement wiring1

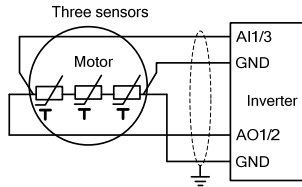

Figure7-47-B Motor temperature measurement wiring2

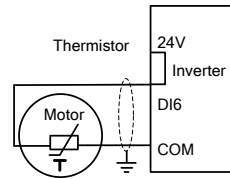

Figure 7-47-C Motor temperature measurement wiring3

The motor temperature can also be measured by connecting the thermoswitch to multifunctional input terminals of frequency inverter ( Function No. 62). See Figure 7-47-C for wiring (such as DI6 terminal, that is, F3.0.05=62)

<b>F5.4.44 Sensor current source</b>	<b>Setting range: 0~2</b>	<b>Factory default: 100.0</b>
--------------------------------------	---------------------------	-------------------------------

The functional parameter is used to define the current source port of PT100 or PTC sensor.

**0: None**

**1: AO1**

Sensor current source port is the multifunctional analog output **AO1** and the signal type of output should be current signal (dial switch of control panel).

**2: AO2**

Sensor current source port is the multifunctional analog output **AO2** and the signal type of output should be current signal (dial switch of control panel).



- The parameter will not only modify but also lock the selected AO port's relevant parameters, and set them forcibly as fixed value output. When using PT100 sensor, the port supplies 4.00mA's constant current; When using PTC sensor, the port supplies 1.60mA's constant current.

<b>F5.4.45 Temperature input source</b>	<b>Setting range: 0~3</b>	<b>Factory default: 0</b>
---	---------------------------	---------------------------

This parameter is used to define the input channel of temperature signal.

**0: None**

**1: AI1 input (PT100 or PTC)**

The temperature signal of **PT100** or **PTC** sensor should be inputted through analogy input Channel AI1.

**2: AI3 input (PT100 or PTC)**

The temperature signal of **PT100** or **PTC** sensor should be inputted through analogy input Channel AI3.

**3: DI1~DI9 (thermoswitch)**

The temperature signal of thermoswitch should be inputted through multifunctional input terminals Channel **D1-D19** (Function No. 62).

<b>F5.4.46 Warning action threshold value</b>	<b>Setting range: -10.0~500.0°C (0~5000Ω/PTC)</b>	<b>Factory default: 110.0</b>
<b>F5.4.47 Protection action threshold value</b>	<b>Setting range: -10.0~500.0°C (0~5000Ω/PTC)</b>	<b>Factory default: 130.0</b>

This parameter is used to define the alert action point and protective action point for over-temperature detection; The unit should be determined by the motor temperature sensor used.

## 7.26 MULTI-STAGE FREQUENCY SETTING (GROUP F6.0)

<b>F6.0.00~F6.0.14 Preset speed 1~15</b>	<b>Setting range: [ F0.1.22]~[ F0.1.21]</b>	<b>Factory default: 5.00~50.00</b>
--	---	------------------------------------

The parameter is for the setup of multi-stage operation's frequency and can be used to multistage velocity operation and simple programmable multi-stage operation. Refer to the detailed specifications of multi-velocity control function 1, 2, 3, 4 of multifunctional input terminals **F3.0.00-F3.0.07** and simple programmable multistage operation in **F6.1** group parameters. Frequency inverter can transform frequency and direction automatically according to the running time to satisfy the requirement of technology, as Figure 7-48-A shown.

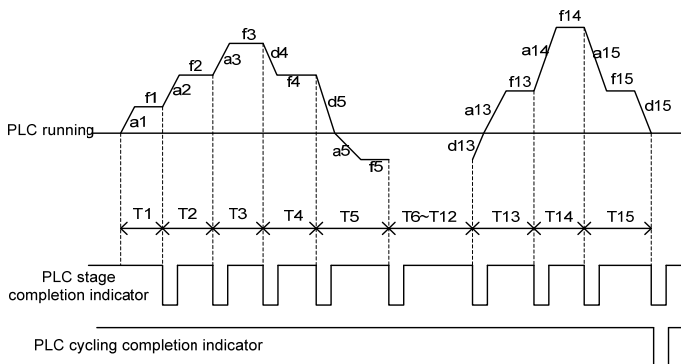

Figure 7-48-A Simple PLC operation

In the figure, **a1-a15** and **d1-d15** are current stage's time of acceleration and deceleration, while **f1-f15** and **T1-T15** are current stage's given frequency and operating time. All these will be defined in this parameter respectively.

The completion of simple programmable multi-stage operation for stage, cycle and so on can access to multifunctional output terminals or relay's output index signal. Refer to Function 20, 21 (multi-stage operation completed) and 22 (multi-stage operating cycle completed) among the **F3.1.15-F3.1.20**.

<b>F6.0.15 Programmable multi-stage mode</b>	<b>Setting range: 0000~1254</b>	<b>Factory default: 0000</b>
--	---------------------------------	------------------------------

\_\_\_ X : Function selection

**0: Function selection**

**1: Multi-stage frequency/revolution operation effective**

In case of frequency (revolution) instruction source allowed to the priority, the frequency converter operates in multi-stage frequency/revolution.



## 2: Multi-stage frequency/revolution operation condition effective

When multifunctional input terminal (Function No.23) is valid, frequency inverter operates in multi-stage frequency/revolution; when it is invalid, frequency inverter will automatically access to frequency setup mode allowed to the lower priority.

## 3: Multi-stage PID setting operation effective

When the process PID starts its function, the setup of PID should be set automatically according to given time cycle, at most 7 stages being set (F7.1.27 ~ F7.1.33).

## 4: Multi-stage PID setting operation condition effective

When multifunctional input terminal (Function No. 23) is valid, the multi-stage setting of process PID is also valid, at most 7 stages being set (F7.1.27 ~ F7.1.33).

### \_\_X\_\_: Operation mode

#### 0: Single cycle

Frequency inverter should firstly operate with first multi-stage speed set frequency and output each velocity's frequency according to given operating time. If the given operating time of a certain velocity is of zero, jump out of the velocity; With a cycle's operation, the frequency inverter should stop outputting and input an effective operating instruction once again to run the next cycle. See as Figure 7-48-B.

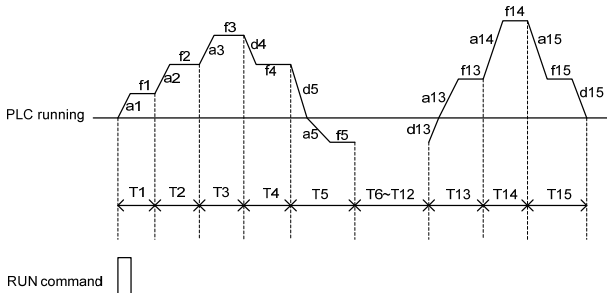

Figure 7-48-B Simple PLC operation single cycle mode

#### 1: Single cycle stop mode

The basic operation mode is the same as mode 0 and its difference is that after frequency inverter operates a stage speed, it firstly lowers the output frequency to zero according to specified deceleration time, then outputs next stage's frequency.

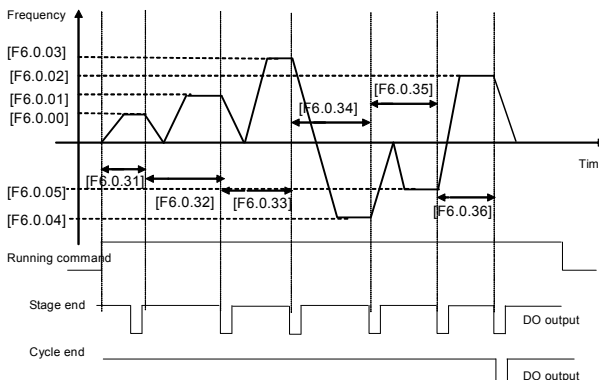

Figure 7-48-C Single cycle stop mode of simple PLC

## 2: Continuous cycling mode

As the figure shown, the frequency inverter starts next cycle after automatically after it finishes a cycle until it receives stop instruction.

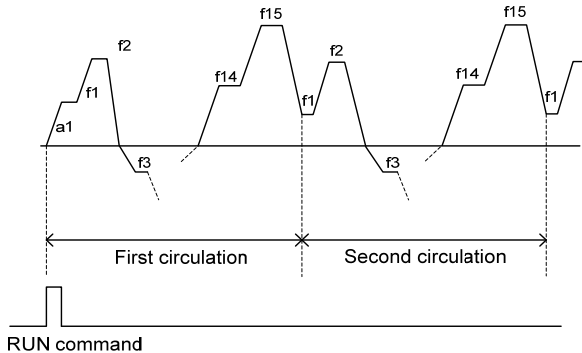

Figure 7-48-D Continuous cycling mode of simple PLC operation

## 3: Continuous cycle stop mode

Basic operation mode is the same as mode 2 and its difference is that after frequency inverter operates a stage speed, it firstly lowers the output frequency to zero according to specified deceleration time, then outputs next stage's frequency.

### 4: Keeping the final value

As the figure shown, the frequency inverter will keep the last stage's operation frequency and direction automatically after it finishes a cycle.

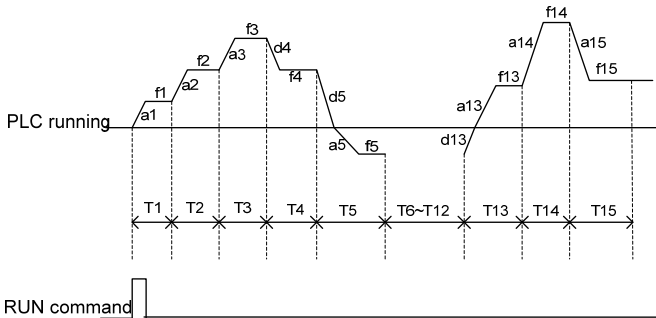

Figure 7-48-E Simple PLC operation keeping the final value mode

## 5: Keeping the final value stop mode

Basic operation mode is the same as mode 4 and its difference is that after frequency inverter operates a stage speed, it firstly lowers the output frequency to zero according to specified deceleration time, then outputs next stage's frequency.

### \_ X \_ : Selection of breakpoint/stop recovery mode

#### 0: Restore running at the first stage

In simple programmable multi-stage operation, frequency inverter will clear out current operation state automatically after it stops because of error stop or stop instruction; Restore running at the first stage after it starts again.

### 1: Start running at the interruption time (effective for multi-stage frequency/ revolution operation)

In simple programmable multi-stage operation, frequency inverter will record the stage operation time and operation frequency automatically at the interrupting time after it stops because of error stop or stop instruction; Start running at the interruption time after it starts again.

### 2: Start running at the stage of interruption

In simple programmable multi-stage operation, frequency inverter will record the stage operation time and operation frequency automatically at the interrupting time after it stops because of error stop or stop instruction; Start running at the stage of interruption after it starts again. The single difference between mode 1 and 2 is the different frequencies at the stage of interruption. See as Figure 7-49.

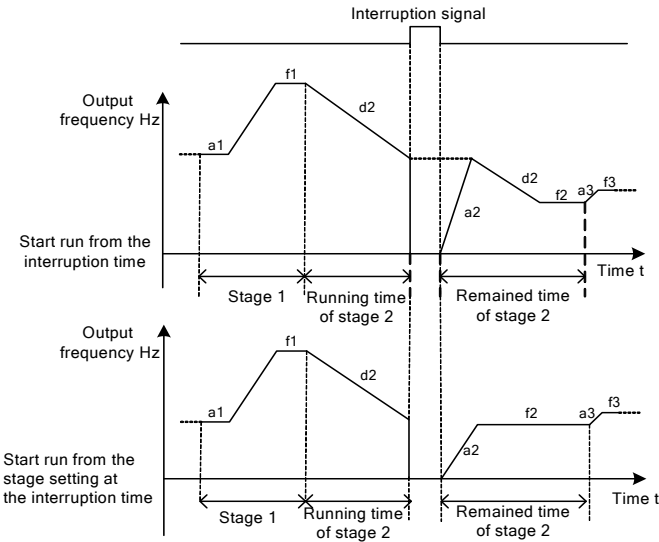

Figure 7-49 Breakpoint recovery sketch

## X \_\_\_ : Power-off status storage

### 0: Not stored

When the frequency converter fails power, it does not store the simple programmable multi-stage operation and starts operating from the first stage after power comes again.

### 1: Stored

When the frequency converter fails power, it stores the simple programmable multi-stage operation, including the power-off status, operation frequency, operated time, and operates according to the parameter's breakpoint/stop recovery mode of hundred definition after power comes again.

## 7.27 SIMPLE PROGRAMMABLE MULTI-STAGE OPERATION (GROUP F6.1)

<b>F6.1.16~F6.1.30</b> Setting of stage 1~15	<b>Setting range: 0000~1321</b>	<b>Factory default:0000</b>
--	---------------------------------	-----------------------------

The unit: Operating frequency source/setting source at each stage

### 0: Multi-stage frequency setting 1~15/Process PID multi-stage setting 1~7 (1~7)

Stage operation frequency set values should be set by multi-stage frequency setting 1~15 (Group F6.0)/ Process PID multi-stage setting 1~7 (Group F7.1).

### 1: Frequency command (F0.1.16)/Process PID setting (F7.0.01)

Stage operation frequency set values should be set by frequency command (F0.1.16)/Process PID setting (F7.0.01).

<b>F6.1.31~ F6.1.45</b> Stage 1 running time	<b>Setting range: 0.0~6500.0</b>	<b>Factory default: 0.0</b>
--	----------------------------------	-----------------------------

The parameter is used to the setting of each stage's operation time; when it occurs to a zero, it means jumping over this operation stage.

## 7.28 SWING FREQUENCY OPERATION (GROUP F6.2)

Swing frequency operation is regulated by upper and lower boundary of frequency. If the function's parameter group is improper, swing frequency operates properly.

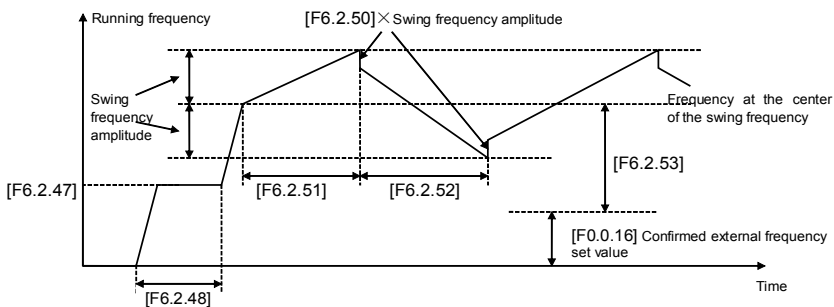

Figure 7-50 Swing frequency operation sketch

<b>F6.2.46</b> Function selecting (H)	<b>Setting range: 0000~1112</b>	<b>Factory default: 0000</b>
---------------------------------------	---------------------------------	------------------------------

\_\_\_ X : Function Setting

### 0: Function closed

The functional parameter of Group F6.2 is available.

### 1: Function effective

In case of frequency (revolution) instruction source allowed to the priority, the frequency inverter adopts swing function.

### 2: Terminal selectivity effective

When the multifunctional input terminal of definition 24 (swing operation input) is valid, the frequency inverter adopts swing function. In case of frequency (revolution) instruction source allowed to the priority. If it invalidates, frequency converter operates with the set value of swing frequency preset frequency **F6.2.47**. In this mode, preset frequency waiting time invalidates.

<b>F6.2.47 Preset frequency of traverse</b>	<b>Setting range: 0.00~[F0.1.21]</b>	<b>Factory default:10.00</b>
<b>F6.2.48 Waiting time for preset frequency</b>	<b>Setting range: 0.0~6000.0Sec.</b>	<b>Factory default: 0.0</b>

Preset frequency is referred to the operation frequency before frequency inverter adopts swing frequency operation or breaks away from operation frequency of swing frequency operation. Determine the operation mode of preset frequency according to the instruction of swing frequency function.

When the selected swing frequency function is valid (**[F6.2.46]=\_ \_ \_ 1**), frequency inverter starts swing frequency preset frequency after running, then runs the swing frequency operation status via the process of preset frequency waiting time.

In case of the selected swing frequency function terminal available (**[F6.2.46]=\_ \_ \_ 2**), when swing frequency operation input terminal is valid, frequency inverter runs the swing frequency operation status; When it invalidates, frequency converter outputs preset frequency (**[F6.2.47]**), and the preset frequency waiting time is unavailable.

<b>F6.2.49 Swing frequency amplitude</b>	<b>Setting range: 0.0~50.0%</b>	<b>Factory default: 10.0</b>
--	---------------------------------	------------------------------

Swing frequency amplitude is the ratio of swing frequency amplitude.

When it occurs to fixed swing frequency amplitude (**[F6.2.46]=\_ 0 \_ \_**), mathematics of practical swing frequency amplitude is:

Practical swing frequency amplitude= **[F6.2.49]** × maximum frequency **[F0.1.20]**

When it occurs to changeable swing frequency amplitude (**[F6.2.46]=\_ 1 \_ \_**), mathematics of practical swing frequency amplitude is:

Practical swing frequency amplitude= **[F6.2.49]** × (preset frequency of swing frequency center **[F6.2.53]** + frequency set value **F0.1.16**)

<b>F6.2.50 Sudden jump frequency</b>	<b>Setting range: 0.0~50.0%</b>	<b>Factory default: 10.0</b>
--------------------------------------	---------------------------------	------------------------------

Sudden jump frequency is the amplitude of frequency's fast descending after it reaches upper boundary in swing frequency cycle, that is, the amplitude of frequency's fast ascending after it reaches lower boundary. See in detail the Reference Diagram 7-50.

Practical sudden jump frequency = **[F6.2.50]** × practical swing frequency amplitude.

<b>F6.2.51 Rise time of triangular wave</b>	<b>Setting range: 0.0~1000.0Sec.</b>	<b>Factory default: 10.0</b>
<b>F6.2.52 Fall time of triangular wave</b>	<b>Setting range: 0.0~1000.0Sec.</b>	<b>Factory default: 10.0</b>

The parameter in this group is referred to acceleration and deceleration slope in the process of swing frequency.

Triangular wave rising time is referred to the time spent from the lower boundary frequency to the upper boundary frequency in swing frequency operation, that is, the acceleration time in the cycle of swing frequency operation.

Triangular wave decreasing time is referred to the time spent from the upper boundary frequency to the lower boundary frequency in swing frequency operation, that is, the deceleration time in the cycle of swing frequency operation.

The sum of triangular wave rising time and decreasing time is the swing frequency operation cycle.

<b>F6.2.53 Center frequency setting of traverse</b>	<b>Setting range: 0.00~[F0.1.21]</b>	<b>Factory default: 10.00</b>
---	--------------------------------------	-------------------------------

Frequency setting in the center of the swing frequency is referred to the center value of frequency converter output frequency in the process of swing frequency operation.

Center frequency of practical output = [F6.2.53] + F0.1.16 certain set frequency

Refer to the following figure for the structure of Process PID and functions of each functional parameters:

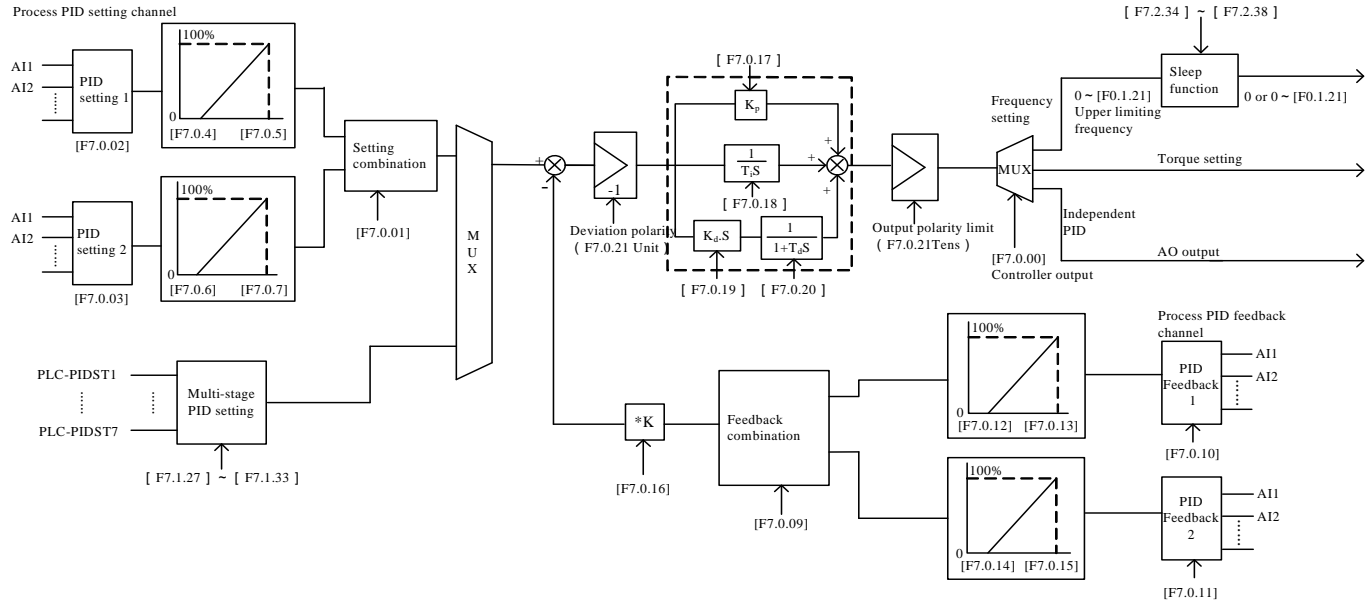

Figure 7-51 Schematic block of process PID control

## 7.29 PROCESS PID (4MS CONTROL CYCLE) (GROUP F7.0)

<b>F7.0.00 Process PID function selection</b>	<b>Setting range: 0000~2102</b>	<b>Factory default: 0000</b>
---	---------------------------------	------------------------------

Process PID works when frequency setting channel (F0.2.25, F0.2.26 value 23) functional, and need set frequency reference priority selection (F5.3.28) to 0007, then the output of the process PID be as the frequency command of frequency setting channel, the upper limit of this frequency command will be chosen by the kilobit of this parameter. This function is mainly applied in occasions of PID output and external set superposition. Wake up/sleep is invalid in this mode.

**X \_ \_ \_:** The main and auxiliary superposition mode refer to frequency reference

### 0: Upper frequency limit

The frequency reference determined by the maximum value of chosen PID function frequency setting channel.

### 1: superposition channel set value

The frequency reference determined by the value of unselected PID function frequency setting channel.

### 2: superposition channel set value/upper frequency-superposition channle setting

When the set value of PID output and superposition channel have the same sign, reference frequency will be "frequency-superposition channel setting", otherwise it will be superposition channel set value.

If want wakeup/sleep of process PID functional, the priority of rated output mode must higher than frequency setting channel. (F5.3.28=0000 or 0001)

<b>F7.0.04 Analog input minimum value (Channel 1)</b>	<b>Setting range:0.0V~[F7.0.05]/ AI2: 0.0mA~[F7.0.05]</b>	<b>Factory default: 0.0</b>
<b>F7.0.05 Analog input maximum value (Channel 1)</b>	<b>Setting range:[F7.0.04]~10.00/ AI2: [F7.0.04] ~20.00mA</b>	<b>Factory default: 10.00</b>
<b>F7.0.06 Analog input minimum value (Channel 2)</b>	<b>Setting range:0.0V~[F7.0.07]/ AI2: 0.0mA~[F7.0.07]</b>	<b>Factory default: 0.0</b>
<b>F7.0.07 Analog input maximum value (Channel 2)</b>	<b>Setting range:[F7.0.06]~10.00/ AI2: [F7.0.06] ~20.00mA</b>	<b>Factory default: 10.00</b>

When analog channel input is selected for setting source of process **PID**, corresponding relationship between set value of process **PID** and analog port can be altered with this group of parameters. The corresponding relationship is shown in Figure 7-52.

<b>F7.0.12 Actual value 1 minimum (feedback channel 1)</b>	<b>Setting range: 0.0~[F7.0.13]/ AI2: 0.0mA~[F7.0.13]</b>	<b>Factory default: 0.0</b>
<b>F7.0.13 Actual value 1 maximum (feedback channel 1)</b>	<b>Setting range: [F7.0.12]~10.00V/ AI2:[F7.0.12] ~20.00mA</b>	<b>Factory default: 5.00</b>
<b>F7.0.14 Actual value 2 minimum (feedback channel 2)</b>	<b>Setting range: 0.0~[F7.0.15]/ AI2: 0.0mA~[F7.0.15]</b>	<b>Factory default: 0.0</b>
<b>F7.0.15 Actual value 2 maximum ( feedback channel 2)</b>	<b>Setting range: [F7.0.14]~10.00V/ AI2: [F7.0.14] ~20.00mA</b>	<b>Factory default: 5.00</b>

When the analog channel input is selected for feedback source of process **PID**, corresponding relationship



between feedback value of process **PID** and analog port can be altered with this group of parameters. The corresponding relationship is shown in Figure 7-53.

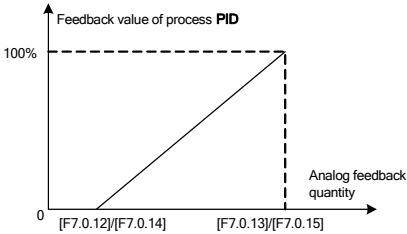

Figure 7-52 Sketch of set value of process **PID**

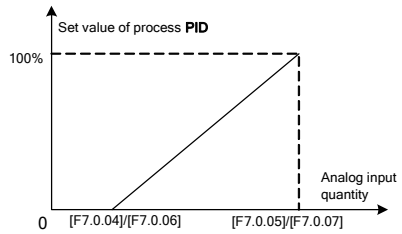

Figure 7-53 Sketch of corresponding relationship of feedback value of process **PID**

<b>F7.0.16 Actual value multiplication factor</b>	<b>Setting range: 0.01~100.00</b>	<b>Factory default: 1.00</b>
---	-----------------------------------	------------------------------

This function is mainly applied in occasions of flow calculation with differential pressure. When the feedback value is not in accordance with the given value of process **PID**, while there is a certain linear relation, this group of parameters can be selected to make it accordant of the meaning expressed by feedback value and given value of process **PID**. For example, if the given value of process **PID** means flow of the pipe, feedback value of process **PID** means flow rate of the pipe, supposing the set value of this parameter means cross sectional area (CSA) of the pipe, then the given value and feedback value of process **PID** shall be in accordance.

<b>F7.0.17 Proportional gain</b>	<b>Setting range: 0.0~100.00</b>	<b>Factory default: 2.00</b>
<b>F7.0.18 Integral time</b>	<b>Setting range: 0.0, 0.1~1000.0Sec.</b>	<b>Factory default: 20.0</b>
<b>F7.0.19 Differential quotient</b>	<b>Setting range: 0.0, 0.01~10.00</b>	<b>Factory default: 0.0</b>
<b>F7.0.20 Differential inertia filtering time</b>	<b>Setting range: 0.01~100.00 Sec.</b>	<b>Factory default: 10.00</b>

Proportional gain defines the magnification of deviation. The bigger the set value is, the faster the response of system is, but oscillation can be caused when it's too big; the smaller the set value is, the slower the response is. Adjusting only with proportional gain will not eliminate the deviation completely. In order to eliminate the remained deviation, integral time shall be selected. The smaller the integral time is set, the faster the response is, but oscillation of system can be caused when it's too big or too small.

Differentiator can make response to the change rate of deviation. The larger the change is, the larger the output gain is, that is, its gain is in proportion to change rate of deviation. But it won't make response to constant deviation. When differential coefficient is 0.0, it means the differential function closing the controller. Differential function can improve the responsibility of system.

The larger the differential coefficient is set, the stronger the differential function is. In general system, there is no need to introduce differential link.

Larger differential inertia filtering time can make the differential adjustment more smoother, generally, it is set in proportion to the inertia of system.

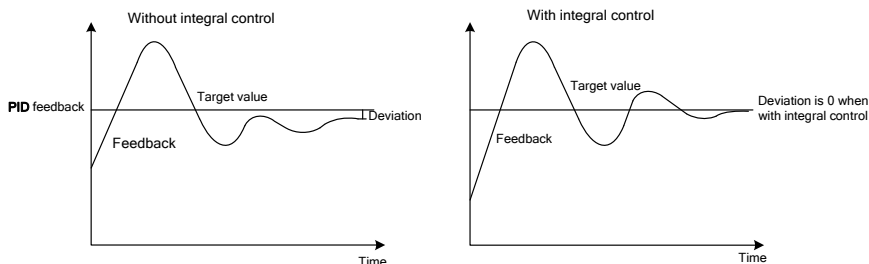

Figure 7-54 Function of integral control

<b>F7.0.21 Configuration of standard PID controller</b>	<b>Setting range: 0000-0111</b>	<b>Factory default: 0000</b>
---	---------------------------------	------------------------------

\_\_\_ X : Dviation polarity

**0: Positive deviation**

When feedback signal gets weaker, PID output is increased.

**1: Negative deviation**

When feedback signal gets weaker, PID output is decreased.

\_\_ X \_ : Output polarity

**0: Single polarity**

**1: Dual polarity**

For single polarity of PID control mode, output of PID adjuster is always positive value, lower limit is 0. For frequency settings, operation direction of frequency inverter is determined with external control order, while PID output can't change the operation direction. Generally, it applies for devices without motor reversal for water and pressure delivery. Refer to Figure 7-55-A.

For dual polarity of PID control mode, output of PID adjuster is negative value. For frequency settings, operation direction of frequency inverter is determined with external control order and "Exclusive OR" calculation of PID output direction, and PID output can change the operation direction. If the direction lock parameter (F0.1.17) is valid, efficient PID output shall take the absolute value. Refer to Figure 7-55-A and Figure 7-55-B.

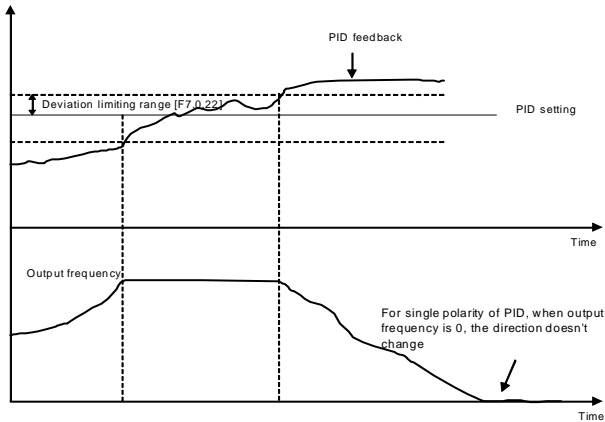

Figure 7-55-A Single polarity of PID control mode

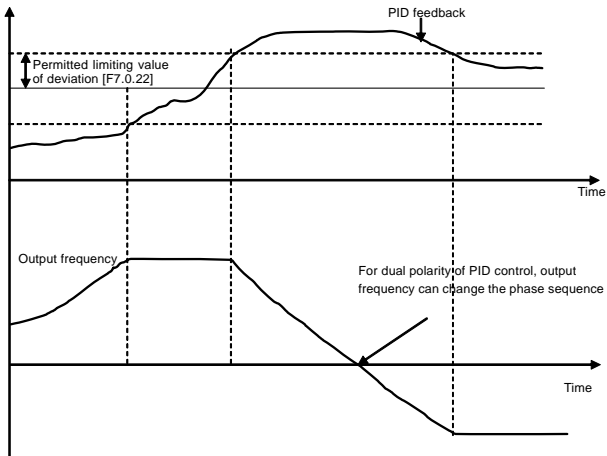

Figure 7-55-B Dual polarity of PID control mode

<b>F7.0.22 Permitted static deviation (relative 100% setting)</b>	<b>Setting range: 0.0~20.0%</b>	<b>Factory default:5.0</b>
---	---------------------------------	----------------------------

Controller output value is the permitted maximum deviation amount with given value of controller. When feedback value is within the range of maximum deviation range, the controller stops adjusting. Proper setting of his function contributes to covering the accuracy and stability of output of system.

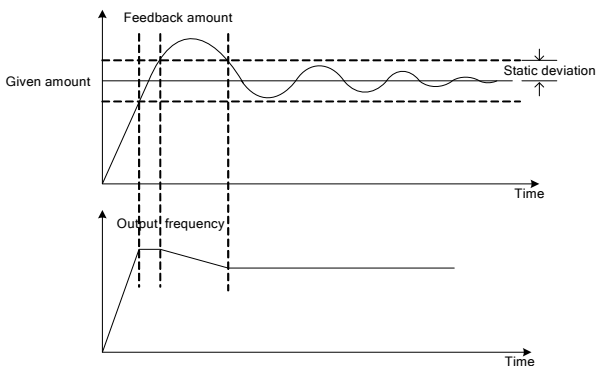

Figure 7-56 Sketch of static deviation

<b>F7.0.23 PID output preset</b>	<b>Setting range: 0.0~100.0%</b>	<b>Factory default:0.0</b>
<b>F7.0.24 Preset hold time before PID starting</b>	<b>Setting range: 0.0~3600.0Sec.</b>	<b>Factory default:0.0</b>

This function can make it earlier to access to the stable stage for PID adjustment. Preset value of PID output is the relevant percentage of upper limiting frequency [F0.1.21].

When frequency inverter start to operate, first of all, it shall be sped up to the preset frequency of PID, and operate as closed-loop characteristics after running continually for a while at this point of frequency [F7.0.24].

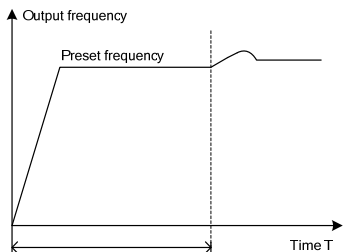

Figure 7-57 Sketch of closed-loop preset frequency operation

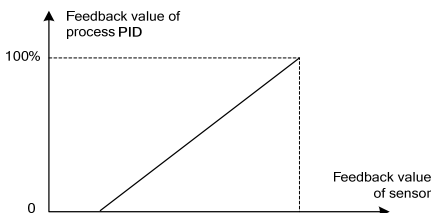

Figure 7-58 Relationship curve of feedback percentage and corresponding sensor value

<b>F7.0.25 Actual sensor value (range) corresponding to 100% feedback</b>	<b>Setting range: 0.01~100.00</b>	<b>Factory default: 1.00</b>
<b>F7.0.26 Actual sensor value corresponding to 0% feedback</b>	<b>Setting range: -100.00~100.00</b>	<b>Factory default: 0.0</b>

This group of parameter determines the corresponding relationship between feedback percentage and feedback physical quantity, which determines monitoring the displayed dimension of parameter d0.1.36 and d0.1.37. Corresponding relationship curve is shown in Figure 7-58.

## 7.30 PROCESS PID MULTI-STAGE SETTING (GROUP F7.1)

**F7.1.27~F7.1.33 Process PID multi-stage preset**

**Setting range: -100.0~100.0%**

**Factory default: 0.0**

This group of parameter defines the set value of process **PID** multi-stage operation. Set value is the relevant percentage of process **PID** set value determined in **F7.0.01**.

Multi-stage operation of process **PID** can be flexibly realized with multifunction input terminal, please refer to function instruction of given terminal 1, 2, 3(28~30) of multi-stage process **PID** of terminal function **F3.0.00 ~ F3.0.08**.

## 7.31 PROCESS PID SLEEPING FUNCTION (GROUP F7.2)

This function is valid when **PID** output conducts frequency order; Sketch is shown as below:

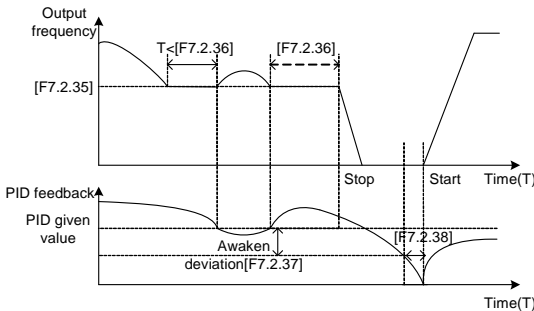

Figure 7-59 Sketch of PID sleeping function



- Set value of awakens deviation is the relevant percentage of **PID** given value.

## 7.32 REVOLUTION SETTING AND FEEDBACK (GROUP F8.0)

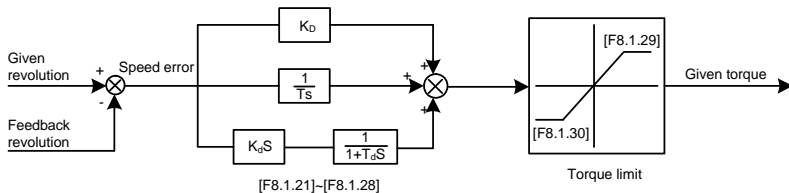

Figure 7-60 Closed-loop block diagram of revolution

This group of parameter is valid with **VC** and **SVC** modes.

<b>F8.0.00 Revolution setting channel</b>	<b>Setting range: 0~10</b>	<b>Factory default: 0</b>
---	----------------------------	---------------------------

This parameter is used to define revolution setting channel. Selecting mode of revolution setting channel is similar with that of frequency setting source channel. Refer to instruction of **F0.2.25** parameter.

**0: Set by frequency setting parameter (F0.1.16)**

Revolution set value is obtained from transition of frequency set value selected by F0.1.16: Revolution setting=frequency set value\*60/pairs of motor polarity

**1: Keypad reference (F8.0.03)**

Value of **F8.0.03** is set as revolution set value, automatically preserved when outage.

**2: Keypad potentiometer**

Revolution set value is given by revolving panel shuttle potentiometer.

**3: Analog input AI1**

**4: Analog input AI2**

**5: Analog input AI3 (Bipolarity)**

**6: Frequency signal input (Fin)**

Take the pulse signal input by pulse input port **Fin** as revolution set value.

**7: MODBUS Fieldbus set value 1 (relative setting)**

**8: MODBUS Fieldbus set value 2 (absolute setting)**

**9: Virtual analog input SAI1**

**10: Virtual analog input SAI2**

Note: Select revolution setting channels 3~7, upper and lower limiting parameters shall be correctly selected F8.0.01 and F8.0.02.

<b>F8.0.01 Rotational speed minimum</b>	<b>Setting range: 0~60*[F0.1.21]/pairs of motor poles (rpm)</b>	<b>Factory default: 0</b>
<b>F8.0.02 Rotational speed maximum</b>	<b>Setting range: 0~60*[F0.1.21]/pairs of motor poles (rpm)</b>	<b>Factory default: 1500</b>

This parameter is used to set the relationship curve of set value and corresponding motor revolution when revolution channel is analog input port of this parameter.

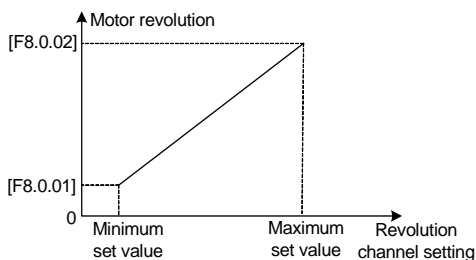

Figure 7-61 Corresponding relation of revolution set value and motor revolution

<b>F8.0.06 PG rotation direction</b>	<b>Setting range: 0, 1</b>	<b>Factory default: 0</b>
--------------------------------------	----------------------------	---------------------------

In the system of inductive vector controlling, frequency inverter output phase sequence (depending on the connection order between the motor and frequency inverter U, V, W) and the connection order between pulses of encoder Phase A and Phase B should keep uniform. Or it can't function normally and cause the **Fu.020** fault or 0 speed shock when starting. Then it can be solved with modifying the parameter.



- Systems of tension control or hoisting equipment, etc. which may lead to motor shaft side-pulling, may result in Fu.020 fault and at this moment please shield the protective function (FF.1.22 = # 0 # #).

<b>F8.0.09 Revolution check cycle</b>	<b>Setting range: 1~5ms</b>	<b>Factory default: 2ms</b>
---------------------------------------	-----------------------------	-----------------------------

When revolution feedback channel selects an encoder, the parameter sets speed check cycle.

The parameter should set smaller values; Overlarge revolution check cycle may lead to unstable closed-loop running and decelerate response. When use larger check cycle for ensuring the exactness of measuring speed, please lower the proportionality factors F8.1.21, F8.1.25 of revolution closed-loop regulator and enlarge integral time constants F8.1.22, F8.1.26 moderately.

<b>F8.0.11 Loss of rotational feedback signal delay</b>	<b>Setting range: 0.01~5.00Sec.</b>	<b>Factory default: 2.00</b>
<b>F8.0.12 Power failure speed</b>	<b>Setting range: 0~20.0%</b>	<b>Factory default: 0.0</b>

When set revolution is bigger than the wire breakage zero speed signal level (its set value is relative to the percentage of the largest set speed [**F8.0.02**]), while feedback speed is smaller than wire breakage zero speed signal level, and revolution of frequency inverter checks wire breakage protective function after keeping the set time of **F8.0.11**.

<b>F8.0.13 Rotational feedback sensitivity</b>	<b>Setting range: 0.1~100.0</b>	<b>Factory default: 5.0</b>
--	---------------------------------	-----------------------------

If speed measuring loop interference is great, it can enlarge [**F8.0.13**] to prevent wrong judgments from interference; otherwise decrease the set value to strengthen the response speed of the system to wire breakage check.

<b>F8.0.14 Rotational feedback filter time</b>	<b>Setting range: 1~50ms</b>	<b>Factory default: 2ms</b>
--	------------------------------	-----------------------------

Filtering time coefficient of set revolution feedback in this parameter is available to all of the speed measuring modes (channels). When use encoder for speed measuring, the function is similar to check cycle parameter (**F8.0.09**), therefore there is a need to set smaller values for the system of fast-speed response.

<b>F8.0.15 Rotational feedback minimum value (not PG)</b>	<b>Setting range: 0~30000rpm</b>	<b>Factory default: 0</b>
<b>F8.0.16 Rotational feedback maximum value (not PG)</b>	<b>Setting range: 0~30000rpm</b>	<b>Factory default: 1500</b>

The parameter is used to set relations between revolution feedback signal (feedback channel 1~4) and the corresponding to the motor feedback.

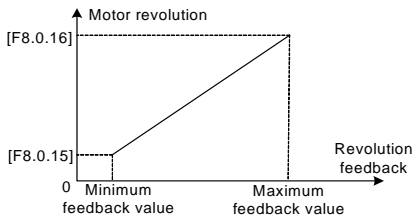

Figure 7-62 Corresponding Relation of Revolution Feedback Value and Motor Revolution

### 7.33 REVOLUTION CLOSED-LOOP PARAMETER (GROUP F8.1)

<b>F8.1.18 Controller parameter selection</b>	<b>Setting range: 0, 1, 2</b>	<b>Factory default: 2</b>
---	-------------------------------	---------------------------

0: Single PID parameter (the second group of parameters is effective by default)

1: Dual PID parameter (hysteresis switching)

2: Dual PID parameter (continuous switching)

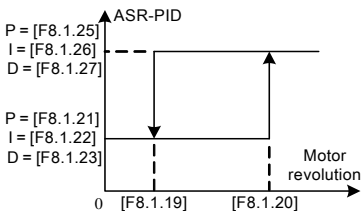

Figure 7-63-A Double PID parameter (hysteresis switching)

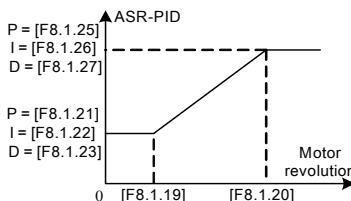

Figure 7-63-B Double PID parameter (continuous switching)

<b>F8.1.19 PID revolution with parameter switching</b>	<b>Setting range: 0~[F8.1.20]</b>	<b>Factory default: 100</b>
<b>F8.1.20 PID parameter switching upper limiting revolution</b>	<b>Setting range: [F8.1.19]~60* [F0.1.21] Motor pole pairs (rpm)</b>	<b>Factory default: 300</b>

The parameters are effective in the condition of double PID parameter hysteresis switching; the first group parameter is effective when it is lower to switching lower revolution [F8.1.18]; The second group parameter is effective when it is higher than switching upper revolution.

<b>F8.1.21 Proportional gain 1 (ASR-P1)</b>	<b>Setting range: 0.1~2.00</b>	<b>Factory default: 1.00</b>
<b>F8.1.22 Integral time 1 (ASR-I1)</b>	<b>Setting range:0.0,0.01~50.00Sec.</b>	<b>Factory default: 1.00</b>
<b>F8.1.23 Differential coefficient 1 (ASR-D1)</b>	<b>Setting range: 0.0, 0.01~10.00</b>	<b>Factory default: 0.0</b>
<b>F8.1.24 Differential output filtering constant 1 (ASR-DT1)</b>	<b>Setting range:0.10~5.00Sec.</b>	<b>Factory default: 1.00</b>



<b>F8.1.25 Proportional gain 2 (ASR-P2)</b>	<b>Setting range: 0.1~2.00</b>	<b>Factory default: 0.80</b>
<b>F8.1.26 Integral time 2 (ASR-I2)</b>	<b>Setting range:0.0,0.01~50.00Sec.</b>	<b>Factory default: 2.50</b>
<b>F8.1.27 Differential coefficient 2(ASR-D2)</b>	<b>Setting range: 0.0, 0.01~10.00</b>	<b>Factory default: 0.0</b>
<b>F8.1.28 Differential output filtering constant 2(ASR-DT2)</b>	<b>Setting range: 0.10~10.00 Sec.</b>	<b>Factory default: 1.00</b>

The parameters are applied to adjust proportional gain of speed adjuster, integral time and differential coefficient. Each parameter should be set as following:

- 1) Proportional gain P: As value is bigger, the response is faster, however the stability of system is worse and overlarge gain can lead to revolution shock.
- 2) Integral time coefficient I: As value is greater, the response is faster, and the revolution over-adjusting is greater, while the stability is worse. In general, the parameters are direct proportional to system inertia. When inertia is great, the parameter also set with great value.
- 3) Differential coefficient D: it is the reverse to differential time constant; there is no need in general system and it should be set to be zero. Differential adjusting in reality is a kind of trend forecasting adjustment; The parameter set is bigger, the differential function is stronger. Proper differential set can fast the response speed, improve the stability, and it is used to the system with requirements of less inertia and fast response.
- 4) Differential output filtering time constant DT: Differential output to the adjuster for a stage of inertia filtering time constant is generally set direct proportion to system inertia.

<b>F8.1.29 Maximum torque output</b>	<b>Setting range: 0.0~250.0%</b>	<b>Factory default: 190.0</b>
<b>F8.1.30 Minimum torque output</b>	<b>Setting range: -250.0~0.0%</b>	<b>Factory default: -190.0</b>

The parameter is applied to set adjuster output amplitude and limit system's transient forward and backward torque. Its set value is the percentage corresponding to rated torque.



- Actual output torque is also limited by adjuster output lower limit amplitude [F1.4.47] and should pick up the lower among the two. When running acceleration and deceleration, it is mainly limited by electricity limit level.

## 7.34 PROTECTIVE PARAMETERS (GROUP F8.2)

<b>F8.2.32 Excessive action of revolution deviation (DEV)</b>	<b>Setting range: 0~3</b>	<b>Factory default: 0</b>
<b>F8.2.33 Over speed (OS) detection action</b>	<b>Setting range: 0~3</b>	<b>Factory default: 1</b>

The parameter is used to set excessive action of revolution deviation (**DEV**) and over speed (**OS**) detection action.

### 0: No action

Inverter keeps on running without reporting any fault or warning message.

### 1: Alarm free stop

Inverter immediately blockades output and reports overlarge deviation of rotating speed (**Fu.018**) or over-speed fault (**Fu.019**), while electric motor freely coasts to stop

**2: Alarm deceleration stop**

Inverter slows down to stop according to effective time of deceleration, and reports overlarge deviation of rotating speed (**Fu.018**) or over-speed fault (**Fu.019**).

**3: Alarm continuing running**

Inverter keeps on running, whereas reports overlarge deviation of rotating speed (**aL.018**) or over-speed warning (**aL.019**) at the same time.

<b>F8.2.34</b> Detected value of excessive revolution deviation (DEV)	<b>Setting range:</b> 0.0~50.0%	<b>Factory default:</b> 20.0%
<b>F8.2.35</b> Detection time of excessive revolution deviation (DEV)	<b>Setting range:</b> 0.0~10.00Sec.	<b>Factory default:</b> 10.00

These parameters are used to set detecting value and time for overlarge deviation of rotating speed (**DEV**).

Provided that deviation of rotating speed is continuously greater than given **DEV** detecting value within given **DEV** detecting time [**F8.2.35**], then inverter shall be in line with the setting action of **F8.2.32**. Set value of **F8.2.34** is corresponding to the percentage of upper limit frequency [**F0.1.21**].

<b>F8.2.36</b> Detected value of over speed (OS)	<b>Setting range:</b> 0.0~150.0%	<b>Factory default:</b> 120.0%
<b>F8.2.37</b> Detection time of over speed (OS)	<b>Setting range:</b> 0.0~2.00Sec.	<b>Factory default:</b> 0.10

These parameters are used to set detecting value and time of over-speed (**OS**).

Provided that feedback rotating speed is continuously faster than given **OS** detecting value within given **OS** detecting time [**F8.2.37**], then inverter shall be in line with the setting action of **F8.2.33**. Set value of **F8.2.36** is corresponding to the percentage of upper limit frequency [**F0.1.21**].

**7.35 TORQUE CONTROL (GROUP F8.3)**

<b>F8.3.40</b> Selection of torque command channel	<b>Setting range:</b> 0~12	<b>Factory default:</b> 0
--	----------------------------	---------------------------

**0: Digital setting (F8.3.41)**

Take the set value of F8.3.41 as given value of torque, and conduct power failure storage.

**1: Panel shuttle potentiometer setting**

Set value of torque is given by rotational shuttle potentiometer.

**2: Analog input AI1**

AI1 input voltage value of 0~10V is corresponding to 0~250% of rated torque.

**3: Analog input AI2**

AI2 input current value of 4~20mA is corresponding to 0~250% of rated torque.

**4: Analog input AI3**

AI3 input voltage value of -10~10V are corresponding to 0~250% of rated torque.

**5: Analog input AI3 (bipolarity)**

AI3 input voltage value of -10~10V is corresponding to -250%~250% of rated torque; positive and negative input of AI3 are corresponding to positive and negative instruction value of torque.

**6: Frequency signal input (Fin)**

Maximum value of input frequency of Fin terminal is corresponding to 250% of rated torque.

**7: Process PID output**

For process PID output that given as torque instruction, F7.0.00 parameter needs to be set as #1## for matching.

**8: Compensation PID output**

For compensation PID output that given as torque instruction, F9.0.00 parameter needs to be set as #1## for matching.

**9: MODBUS Fieldbus set value 1 (relative set value)**

Current torque instruction of inverter is set by principal computer through built-in standard RS485 communication interface of inverter.

**10: MODBUS Fieldbus set value 2 (absolute set value)****11: Virtual analog input SAI1****12: Virtual analog input SAI2**

<b>F8.3.41 Torque digital setting</b>	<b>Setting range: -250~250%</b>	<b>Factory default: 0.0</b>
---------------------------------------	---------------------------------	-----------------------------

Its set value, the setting with symbols (Direction), is corresponding to the percentage of rated torque; Actual given direction of torque is "Exclusive OR" of control command direction and set value direction.

Refer to the following figure for the structure of compensation PID and functions of each functional parameter:

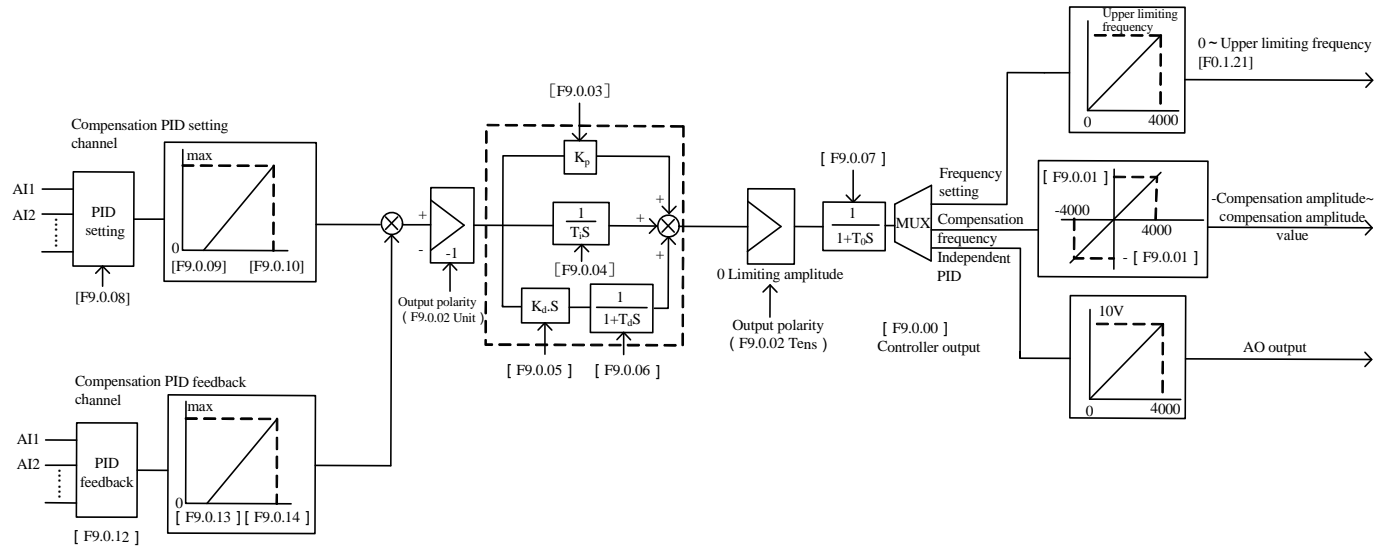

Figure 7-64 Schematic block of compensation PID

## 7.36 COMPENSATION PID (1MS CONTROL CYCLE) (GROUP F9.0)

<b>F9.0.09</b> Analog input minimum value is 0%	<b>Setting range: 0.0V-[F9.0.10]/ AI2:0.0mA-[F9.0.10]</b>	<b>Factory default: 0.0</b>
<b>F9.0.10</b> Analog input maximum value is 100%	<b>Setting range: [F9.0.09]~10.00V/ AI2:[F9.0.09] ~20.00mA</b>	<b>Factory default: 10.00</b>

When the compensation **PID** setting source channel selects the analog channel input, this group of parameters can be used to modify the correspondence relationship between the compensation **PID** set value and the analog pot. The correspondence relationship is shown in Figure 7-65.

<b>F9.0.13</b> Feedback input actual value is 0%	<b>Setting range: 0.0V-[F9.0.14]/ AI2:0.0mA-[F9.0.14]</b>	<b>Factory default: 0.0</b>
<b>F9.0.14</b> Feedback input actual value is 100%	<b>Setting range: [F9.0.13]~10.00V/ AI2:[F9.0.13] ~20.00mA</b>	<b>Factory default: 10.00</b>

This group of parameters can be used to modify the correspondence relationship between the compensation **PID** feedback value and the analog port. The correspondence relationship is shown in Figure 7-66.

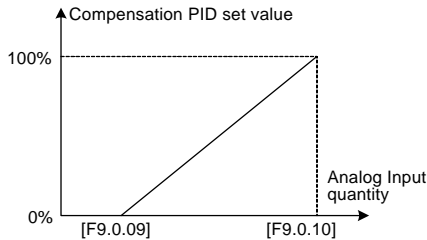

Figure 7-65 Sketch of compensation PID set value definition

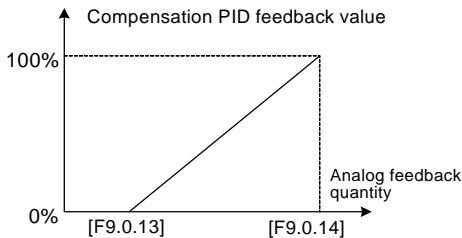

Figure 7-66 Sketch of compensation PID feedback value definition

## 7.37 PARAMETER SELECTION OF COMPENSATION PID CONTROLLER (GROUP F9.1)

There are 4 groups of compensation PID controller parameters, and their switching means are shown in Figure 7-67 ([9.1.21=0023]):

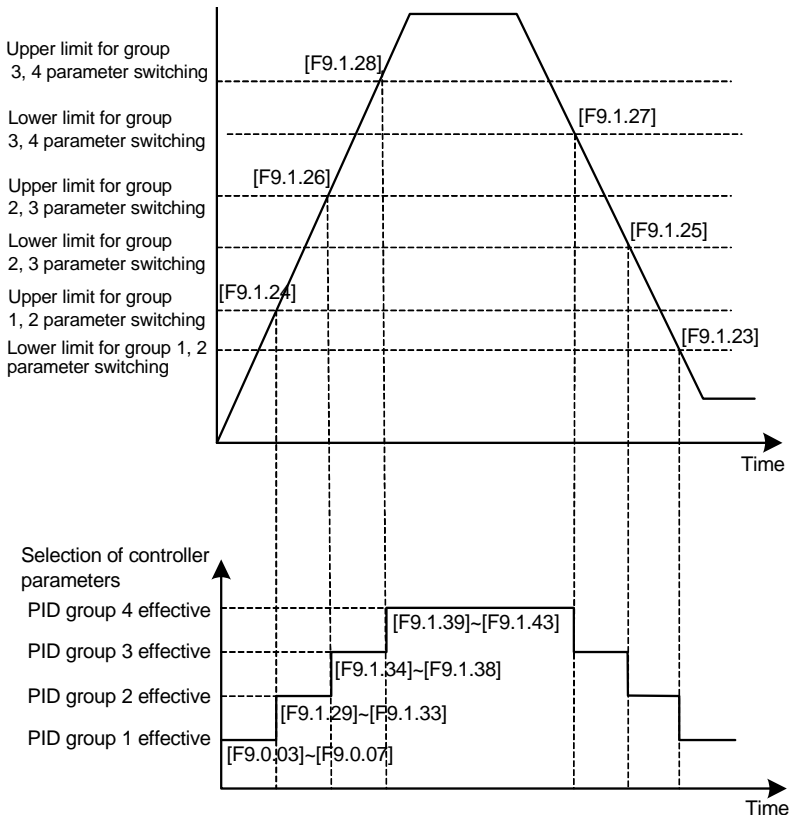

Figure 7-67 Sketch of compensation PID parameter switching

## 7.38 MODBUS FIELDBUS (STANDARD EXPANSION CARD CONFIGURATION) (GROUP FA.0)

<b>FA.0.02 The inverter station address</b>	<b>Setting range: 0~247</b>	<b>Factory default: 1</b>
---	-----------------------------	---------------------------

This parameter is used to set the address of the local inverter in the case of serial port communication. It is only effective when the inverter is a slave one. During communication, the local device only receives commands for the data frames consistent with the address of this device, and then sends back response frames.



- 0 is the broadcasting address. When it is set to the broadcasting address, the device will only receive and execute broadcasting commands and will not respond to the master device.

<b>FA.0.03 The device response delay</b>	<b>Setting range: 0~1000ms</b>	<b>Factory default: 5ms</b>
--	--------------------------------	-----------------------------

The response delay of the inverter refers to the waiting time since the inverter serial port has received and explained the command sent from the slave device till the response frames are sent.

<b>FA.0.04 Communication failure judging time</b>	<b>Setting range: 0.01~10.00Sec.</b>	<b>Factory default: 1.00</b>
---	--------------------------------------	------------------------------

If the local inverter has not received correct data signal beyond the time interval defined by this parameter, then the communication is judged to be failed for the local inverter. The inverter will report **Fu.071** fault, and will act as set by **FA.0.05**.

## 7.39 MAPPING PARAMETER ACCESS (GROUP FA.1)

<b>FA.1.08~FA.1.13 Mapping application parameter 1~6 (H)</b>	<b>Setting range: F0.00~FF.55</b>	<b>Factory default: F0.29/F0.32</b>
<b>FA.1.14~FA.1.23 Mapping status parameter 1~10 (H)</b>	<b>Setting range: d0.00~d1.49</b>	<b>Factory default: d0.00~d0.09</b>

When **V560** series inverter makes access to functional parameters or monitoring parameters via the buss, corresponding address can be predicted directly with the functional code. However, when it is needed to access multiple functional parameters or monitoring parameters with discontinuous address, multiple-frame data are needed in this method.

The mapping parameter access is actually a needle access mode. When accessing (reading or writing) several functional parameters or status parameters with discontinuous address, these parameters can be mapped into an area with continuous address (bus-control parameter area) for accessing.

See the following table for the bus-control parameters (compatible with A510 and V320 series).

Register Name	Access address	Remarks
Control word	0x1300	Can be read as per the loops (1~16)
Set value 1	0x1301	Setting of relative values
Set value 2	0x1302	Setting of absolute values
Mapping application parameter 1	0x1303	The access parameter is set by FA.1.08.

Register Name	Access address	Remarks
Mapping application parameter 2	0x1304	The access parameter is set by FA.1.09.
Mapping application parameter 3	0x1305	The access parameter is set by FA.1.10
Mapping application parameter 4	0x1306	The access parameter is set by FA.1.11.
Mapping application parameter 5	0x1307	The access parameter is set by FA.1.12.
Mapping application parameter 6	0x1308	The access parameter is set by FA.1.13.
Status word	0x1309	Can be read as per the discrete quantity (1~16)
Mapping status parameter 1	0x130A	The access parameter is set by FA.1.14.
Mapping status parameter 2	0x130B	The access parameter is set by FA.1.15.
Mapping status parameter 3	0x130C	The access parameter is set by FA.1.16.
Mapping status parameter 4	0x130D	The access parameter is set by FA.1.17.
Mapping status parameter 5	0x130E	The access parameter is set by FA.1.18.
Mapping status parameter 6	0x130F	The access parameter is set by FA.1.19.
Mapping status parameter 7	0x1310	The access parameter is set by FA.1.20.
Mapping status parameter 8	0x1311	The access parameter is set by FA.1.21.
Mapping status parameter 9	0x1312	The access parameter is set by FA.1.22.
Mapping status parameter 10	0x1313	The access parameter is set by FA.1.23.

The mapping parameters are determined by **FA.1** group of parameters.

For example, in one frame of standard **MODBUS** protocol data, it's impossible to read the status parameters **d0.0.02**, **d0.0.05**, **d1.0.01** and **d1.1.31** and status word once and for all with a common method. To map status parameters into the bus-controlled parameter area with continuous address, set with the following method:

[FA.1.14] = d0.02

[FA.1.15] = d0.05

[FA.1.16] = d1.01

[FA.1.17] = d1.31

Then you it just needs to read the data in the continuous address **0x130A ~ 0x130D**.

## 7.40 COMMUNICATION LINKAGE SYNCHRONOUS CONTROL (GROUP FA.2)

<b>FA.2.26 Linkage setting proportion coefficient</b>	<b>Setting Range: 0.010~10.000</b>	<b>Factory Default: 1.000</b>
---	------------------------------------	-------------------------------

During linkage control, this parameter defines the proportion between the output frequency of the master machine and the slave machine; the parameter of the master inverter does not function.

<b>FA.2.27 Coupling fine proportion adjustment</b>	<b>Setting range: 0~3</b>	<b>Factory default: 0</b>
--	---------------------------	---------------------------

**0: No fine adjustment**

If the fine adjustment source for linkage proportion coefficient is void, then: Slave frequency command =



master frequency command \* [FA.2.26] of the slave machine.

#### 1: Analog input AI1

If **AI1** is selected for the fine adjustment source for linkage proportion coefficient, then: Slave frequency command = master frequency command \* [FA.2.26] of the slave machine \* **AI1/AI1** maximum.

#### 2: Analog input AI2

If **AI2** is selected for the fine adjustment source for linkage proportion coefficient, then: Slave frequency command = master frequency command \* [FA.2.26] of the slave machine \* **AI2/AI2** maximum.

#### 3: Analog input AI3

If **AI3** is selected for the fine adjustment source for linkage proportion coefficient, then: Slave frequency command = master frequency command \* [FA.2.26] of the slave machine \* **AI3/AI3** maximum.

<b>FA.2.28 Slave machine offset frequency/revolution</b>	<b>Setting range: 0, 1, 2</b>	<b>Factory default: 0</b>
--	-------------------------------	---------------------------

This parameter of the master inverter does not function, and it is used to select the auxiliary frequency of the slave machine:

Actual output frequency of the slave machine=master machine frequency command \* slave machine linkage proportion (including fine adjustment) + offset frequency

#### 0: No offset

No offset frequency/revolution; the frequency set value of the slave machine is determined by the frequency command of the master device and the setting of **FA.2.26** and **FA.2.27**.

#### 1: Determined by frequency setting source 1

The frequency set value of the slave machine frequency setting source 1 is regarded as the offset frequency/revolution of the slave machine.

#### 2: Determined by frequency setting source 2

The frequency set value of the slave machine frequency setting source 2 is regarded as the offset frequency/revolution of the slave machine.

<b>FA.2.29 Coupling balance function</b>	<b>Setting range: 0~4</b>	<b>Factory default: 0</b>
--	---------------------------	---------------------------

#### 0: Void

#### 1: Current balance

With reference to the load current of the master device, each slave device will automatically conduct fine adjustment to the output of local device so as to keep consistency with the master device's current.

#### 2: Torque balance

With reference to the torque of the master device, each slave device will automatically 7.

#### 3: Power balance

Each slave motor refers to the main motor power, automatic self-adjustment it's output to ensure the relatively consistent with the main motor power.

#### 4: position synchronous balance

In the multi-motor linkage system with PG close loop vector control, to use the position synchronous balance is able to eliminate the accrued displacement deviation caused by the minor deviation of driver rotate speed. This method requires the motor that runs with linkage has the same parameter in the PG speed detector .

Position synchronous balance can only revise the minor rotate speed deviation. Adjust the synchronous rotate speed function before use the function.

The accrued pulse of subordinate motor in this mode is required to reset simultaneously with the master motor. Thus, only need to operate in the master motor, or make use of the reset terminal of subordinate motor.

<b>FA.2.30 Coupling balancing gain</b>	<b>Setting range: 0.001~10.000</b>	<b>Factory default: 1.000</b>
--	--	-------------------------------

When the linkage balancing function is effective, this parameter is used to set the adjusting gain output by this device, and it is only effective for the slave device. The higher the gain is, the higher the amplitude of the self-balancing adjustment is.

## 7.41 EXPANSION MULTIFUNCTIONAL INPUT TERMINAL (GROUP FB.0 AND FB.1)

The parameters in the access the corresponding extensions to take effect, its function and F3.Group the same parameters.

## 7.42 SERVO CONTROL AND SCALE POSITIONING (GROUP FB.2)

<b>Fb.2.18 Automatic shift switching frequency</b>	<b>Setting range: 0~5.00Hz</b>	<b>Factory default: 1.00</b>
<b>Fb.2.19 Automatic shift switching cycle</b>	<b>Setting Range: 0.10~2.00Sec.</b>	<b>Factory default: 0.3</b>

For equipments with mechanical speed change gear like the spindle, during mechanical shifting, shift jogging can be adopted to avoid mechanical dead. This group of parameters defines the running parameters for shift jogging.

<b>Fb.2.20 Torque at 0 Hz (DC bind-type brake preferred)</b>	<b>Setting range: 0~3</b>	<b>Factory default: 0</b>
<b>Fb.2.21 Position lock gain1(location gain)</b>	<b>Setting range: 0.10~10.00</b>	<b>Factory default: 1.0</b>

**0: Void**

**1: Bind-type brake torque effective**

**2: Position locking (PG feedback VC mode)**

In the running mode of V/F and SVC, the function of zero frequency torque holdup is similar with that of the DC braking function. It cannot guarantee that the motor shaft is absolutely static when it is dragged by the load, and the position gain is void.

In the PG feedback VC control mode, if the zero frequency torque holdup 2 is selected, the drive will automatically memorize the shaft position at stop, and shift to the position serve running mode, so as to guarantee that the shaft will not rotate even under the load dragging.

The higher the position gain is, the stronger the locking torque is.

**3: Lock in the designated stop angle**

It is used to the spindle drive of machine tool to ensure the constant angle in the spindle off. The stop angle is set by Fb 2.45.

<b>Fb.2.22 PG speed shaft propulsion distance per revolution</b>	<b>Setting range: 0.001~50.000mm</b>	<b>Factory default: 0.500</b>
--	--------------------------------------	-------------------------------

This parameter is set the liner displacement of the transmission structure for each revolution of PG speed shaft. The accumulative displacement is shown in the monitoring parameter d1.2.20.

<b>Fb.2.23 Servo control function</b>	<b>Setting range: 0000~0012</b>	<b>Factory default: 0000</b>
---------------------------------------	---------------------------------	------------------------------

\_\_X: **Function selection**

**0: Void** – servo control void, and running in the speed or torque control mode.

**1: Effective** – must be in the closed-loop vector control mode.

**2: External terminal selection (Function No. 69).**

The closed-loop vector control mode must be selected for this function, and the selection will not be effective until the inverter has completely stopped.

\_\_X\_: **Action mode**

**0: Common mode**

**1: Spindle orientation**

<b>Fb.2.24 Position setting source in common mode</b>	<b>Setting range: 0~5</b>	<b>Factory default: 1</b>
<b>Fb.2.25 Position digit setting (lower)</b>	<b>Setting range: 0~65535</b>	<b>Factory default: 0</b>
<b>Fb.2.26 Position digit setting (upper)</b>	<b>Setting range: 0~500</b>	<b>Factory default: 0</b>

This group of parameters is used to define the position command source in the mode of common serve control.

When the analog setting is used to set the position, the maximum analog input is corresponding to 5000 pulse commands.

When digital setting ([Fb.2.24] = 2) is selected as the position setting source, Fb.2.25 and Fb.2.26 are used to set the command position.

<b>Fb.2.27 Electronic gear (numerator)</b>	<b>Setting range: 0~65535</b>	<b>Factory default: 1000</b>
<b>Fb.2.28 Electronic gear (denominator)</b>	<b>Setting range: 0~65535</b>	<b>Factory default: 1000</b>

The electronic gear is used to transform the command pulse to the amount of movement. If the encoder is set to A (pulse per revolution), the displacement per revolution of the motor is B, and the pulse command unit is C, then the electronic gear can be calculated as below:

$$\text{Electronic gear} = 4AC/B$$

The numerator and denominator can be figured out after approximating the common divider.

For example, the encoder of a certain transmission is 1000 lines (A=1000), and motor displacement per revolution is 2 mm (B=2), and the pulse command unit is 1 um (C=0.001m), then the electronic gear is  $4AC/B = 4000 \times 0.001/2 = 2/1$ . Hence, the numerator and the denominator for the electronic gear is respectively 2 and 1.

<b>Fb.2.30 Position gain 2</b>	<b>Setting range: 0.01~100.00</b>	<b>Factory default: 1.00</b>
<b>Fb.2.31 Position gain selection mode</b>	<b>Setting range: 0~3</b>	<b>Factory default: 0</b>
<b>Fb.2.32 Position gain selection position deviation</b>	<b>Setting range: 0~30000</b>	<b>Factory default: 100</b>

In the position gain selection mode, the position gain 1 (Fb. 2.21) is effective when the gain ([Fb.2.31]=3) is selected according to the position deviation, and the position deviation is lower than the set pulse value (Fb.2.32). Otherwise, the position gain 2 (Fb.2.30) will be effective.

<b>Fb.2.33 Speed feed-forward gain</b>	<b>Setting range: 0.0~200.0(%)</b>	<b>Factory default: 100.0</b>
--	------------------------------------	-------------------------------

The higher the position speed feed-forward gain is set, the faster the tracking speed is. However, excessive set value may worsen the stability.

<b>Fb.2.36 Spindle orientation mode</b>	<b>Setting range: 0000~0111</b>	<b>Factory default: 0000</b>
---	---------------------------------	------------------------------

\_\_ \_ X: Selection of positioning zero point reference signals

#### 0: Z Pulse positioning

Z pulse is used to be the reference signal for spindle 0 point (any offset angle can be set according to usual practice). In this mode, the encoder should be installed on the spindle.

#### 1: Photoelectric switch positioning

The photo electricity (or other sensor signal) on the spindle is used as the zero point reference signal.

\_\_ \_ X \_: Positioning command

#### 0: External terminal selection

The value (Fb.2.38~Fb.2.44) preset by the external functional terminal (Function No. 72~74) selection is used as the current positioning command. It is required to correctly set the transmission ratio (Fb.2.46) of the spindle, and when the encoder is installed on the spindle, this vale is set to be 1.000.

#### 1: Pulse command setting

The positioning angle will be determined according to received command pulse. In this mode, it is applicable to adjust the transmission gear with the electronic gear or directly change the command pulse number. Please note that the direction of command pulse should be consistent with the spindle rotation direction, and the spindle transmission ratio (Fb.2.46) should be correctly set.

\_ x \_ \_: locating running direction

#### 0: agreement with the order direction

#### 1: fast locate with the minimum deflection angle

<b>Fb.2.37 Spindle orientation frequency/speed</b>	<b>Setting range: 0.01~100.00Hz</b>	<b>Factory default: 5.00Hz</b>
--	-------------------------------------	--------------------------------

To define the maximum search frequency at the time of spindle positioning.

<b>Fb.2.38~ Fb.2.44 Spindle positioning angle 1~7</b>	<b>Setting range: 0~359.9</b>	<b>Factory default: 0.0~315.0</b>
<b>Fb.2.45 Spindle stop angle</b>	<b>Setting range: 0~359.9</b>	<b>Factory default: 0.0</b>

Setting for multi-stage spindle positioning angle and stop angle.

<b>Fb.2.46 Spindle transmission ratio</b>	<b>Setting range: 0.010~50.000</b>	<b>Factory default: 1.000</b>
---	--	-------------------------------

When the encoder is not directly installed on the spindle, this parameter needs need to be set to achieve correct spindle orientation. This parameter only functions for the spindle orientation function.

Spindle transmission ratio = revolution of the speed shaft: spindle revolution.

## 7.43 VIRTUAL INPUT AND OUTPUT (GROUP FF.0)

<b>FF.0.00 FF configuration parameter locking function (H)</b>	<b>Setting range: 0000~1001</b>	<b>Factory default: 0000</b>
--	---------------------------------	------------------------------

FF group parameters include special and internal function parameters, and their setting and initialization are confined. This group of parameters is used to set the user's authority for operating FF parameters.

<b>FF.0.01~FF.0.08 Definition of virtual output node (SDO1~SDO8)</b>	<b>Setting range: 0~71</b>	<b>Factory default: 0</b>
--	----------------------------	---------------------------

The virtual output nodes **SDO1~SDO8** are functionally the same as the multifunctional output terminals **DO1~DO3**, but do not output any signal. They are directly connected in the controller of the inverter to the virtual input nodes **SDI1~SDI8** one to one.

Using virtual nodes can not only help simplify wiring but can also avoid interference. The function of **SDO1~SDO8** can be defined by setting the value of **FF.0.01~FF.0.08**. Please refer to Table 2 (Comparison Table for Variables of Multifunctional Output Terminals (DO/EDO/SDO) for the variables corresponding to the set value.

<b>FF.0.09~FF.0.16 Definition of virtual input node (SDI1~SDI8)</b>	<b>Setting range: 0~96</b>	<b>Factory default: 0</b>
---	----------------------------	---------------------------

The virtual input nodes **SDI1~SDI8** are functionally the same as the multifunctional input terminals **DI1~DI9**. But there are no actual physical input nodes. They are connected to the virtual output **SDO1~SDO8** one to one, and are directly taken from the virtual output signal.

The virtual input nodes **SDI1~SDI8** are functionally programmable, and their function can be defined by setting the values of **FF.0.09~FF.0.16**. Please refer to Table 1 (Comparison Table for Functions of Multifunctional Input Terminals (DI/EDI/SDI) for functions corresponding to the set value.

<b>FF.0.17 Virtual output - input connection polarity</b>	<b>Setting range: 0000~1111</b>	<b>Factory default: 0000</b>
<b>FF.0.18 Virtual output - input connection polarity</b>	<b>Setting range: 0000~1111</b>	<b>Factory default: 0000</b>

The parameters are used to set the connection logic status of the virtual output nodes **SDO1~SDO8** and virtual input nodes **SDI1~SDI8**. When it is set to be reverse polarity connection, the virtual output signal will be negated before being inputted to the virtual input port, as shown in Figure 7-67.

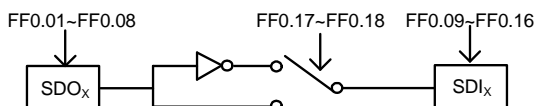

Figure 7-67 Block diagram of virtual output – input

## 7.44 PROTECTING FUNCTION CONFIGURATION PARAMETERS (GROUP FF.1)

This group of parameters is used to define if the protecting function needs to be activated or not. Generally no modification is required.

## 7.45 CORRECTION PARAMETERS (GROUP FF.2)

FF.2.25	AI1 Zero offset adjustment	Setting range: -0.500~0.500V	Factory default: 0.0
FF.2.26	AI1 gain correction	Setting range: 0.950~1.050	Factory default: 1.000

This group of parameters is used to make fine adjustment to AI1 zero point and AI1. The relationship before and after adjustment:

AI1 input value = AI1 gain correction \* AI1 value before adjustment + AI1 zero offset

FF.2.27	4mA deviation adjustment for AI2	Setting range: -0.500~0.500mA	Factory default: 0.0
FF.2.28	AI2 gain correction	Setting range: 0.950~1.050	Factory default: 1.000
FF.2.29	AI3 Zero offset adjustment	Setting range: -0.500~0.500V	Factory default: 0.0
FF.2.30	AI3 gain correction	Setting range: 0.950~1.050	Factory default: 1.000
FF.2.31	AO1 zero offset correction	Setting range: -0.500~0.500V	Factory default: 0.0
FF.2.32	AO1 gain correction	Setting range: 0.950~1.050	Factory default: 1.000
FF.2.33	AO2 zero offset correction	Setting range: -0.500~0.500V	Factory default: 0.0
FF.2.34	AO2 gain correction	Setting range: 0.950~1.050	Factory default: 1.000

The correction principle for each analog input/output port is the same as AI1. The relationship curves with zero offset adjustment and gain correction are respectively as below. Generally, users do not need to set these parameters.

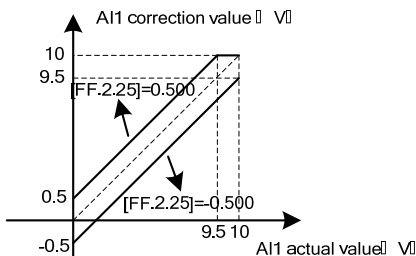

Figure 7-68-A AI1 zero offset correction curve

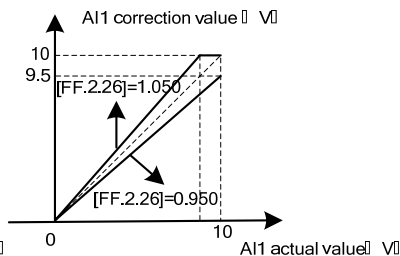

Figure 7-68-B AI1 gain correction curve

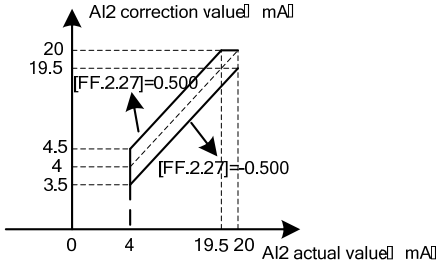

Figure 7-69-A AI2 zero offset correction curve

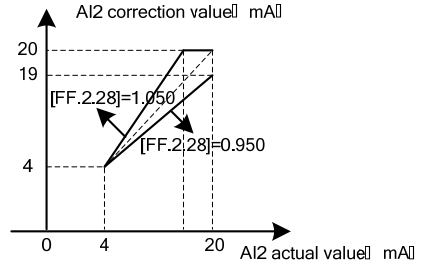

Figure 7-69-B AI2 gain correction curve

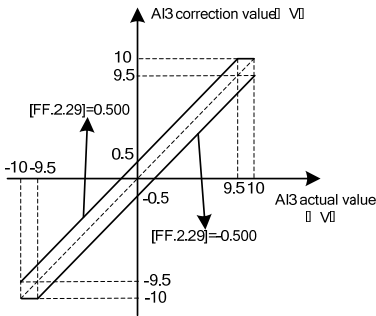

Figure 7-70-A AI3 zero offset correction curve

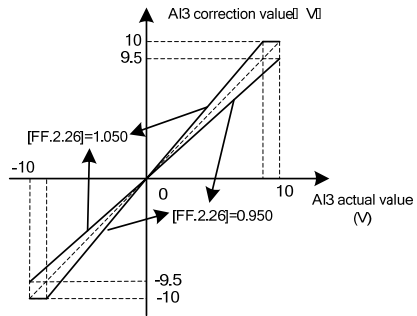

Figure 7-70-B AI3 gain correction curve

<b>FF.2.35 Under voltage protection action level</b>	<b>Setting range: 320~450V</b>	<b>Factory default: 400V</b>
--	--------------------------------	------------------------------

This parameter sets the allowable lower limiting voltage at the DC side during normal operation of the inverter. For some occasions with lower power grid, it is applicable to appropriately reduce the under voltage protection level, so as to ensure normal operation of the inverter.



- When the power grid is under excessive low voltage, the output torque of the motor will decrease. In the occasion of constant power load and constant torque load, excessive low voltage of the power grid will lead to increase of the inverter's input current, hence reducing the reliability of inverter operation.

The set value for this parameter [FF.2.35] must be no more than the under voltage adjustment action level [F1.4.45].

<b>FF.2.36 DC bus volts detection level gain</b>	<b>Setting range: 0.950~1.050</b>	<b>Factory default: 1.000</b>
--	-----------------------------------	-------------------------------

When the actual bus of the inverter is deviated from the value of the DC side voltage monitoring parameter **d0.0.07**, it is applicable to set this parameter combined with the correction of potentiometer in the bus voltage detection circuit.

## 7.46 SPECIAL FUNCTIONAL PARAMETERS (GROUP FF.3)

The modification of this group of parameters should be conducted under the guidance of professionals, and no modification is needed generally.

## 7.47 OTHER CONFIGURATION PARAMETERS (GROUP FF.4)

<b>FF.4.41 Cooling fan control</b>	<b>Setting range: 0000~0111</b>	<b>Factory default: 0101</b>
------------------------------------	---------------------------------	------------------------------

**\_\_ \_ X**: **Soft start function (effective for model 4T0370 below)**

This function helps effectively reducing the instantaneous power required for starting the fan, hence guarantee stable and reliable operation of the switch power supply.

**\_ \_ X \_**: **Air volume auto adjustment (effective for model 4T0370 below)**

The revolution of the cooling fan can be automatically adjusted according to the ambient temperature and operation status of the inverter, so as to maximize service life of the cooling fan.

**\_ X \_ \_**: **Start time**

**0**: **Start immediately after power-on**

The fan will run according to the settings in the unit and ten's digit of this parameter immediately after the inverter is powered on.

**1**: **Start during running**

The fan will run according to the settings in the unit and ten's digit of this parameter after the inverter is powered on and has received the running command.

<b>FF.4.42 Operating panel control options</b>	<b>Setting range: 0000~2001</b>	<b>Factory default: 0000</b>
--	---------------------------------	------------------------------

**X \_ \_ \_**: **Panel control selection (except STOP key)**

**0**: **Standard panel interface control**

The control command can only be given through the standard operating panel, and external monitoring panel can be connected via **RS485**.

**1**: **RS485 port external panel control**

The control command can only be given via **RS485** port, and the standard panel is only used for monitoring.

**2**: **Multifunctional terminal switching**

The master control panel is selected by the multifunctional input terminal (Function No. 40) and the terminal function is set with the parameters **F3.0.00 ~ F3.0.08**.



<b>FF.4.43 Special function configuration</b>	<b>Setting range: 0000~1111</b>	<b>Factory default: 0001</b>
---	---------------------------------	------------------------------

**\_\_X: Motor parameter identification auto-start**

**0: Forbidden**

**1: Permitted**

After modifying the motor nameplate parameters, the inverter will automatically set static self identification of motor parameters once.

**\_\_X\_: Voltage vector composition mode**

**0: Three-phase composition**

**1: Two-phase composition**

Another modulation method for space voltage vector. This method can help appropriately reduce heating of the inverter, but audio noise may somewhat increase.

**\_X\_: Small pulse shielding**

**0: Void**

**1: Effective**

When "Effective" is selected, the heating of the drive can be reduced under full-output voltage.

**X\_\_\_: SVC Revolution identification mode/synchro control mode**

**0: SVC Revolution identification mode 1/synchro id = 0 control mode**

**1: SVC Revolution identification mode 2 (reserved) effective/synchro minimum current control mode**

## 8. WARNING, ALARM DIAGNOSIS AND COUNTER MEASURES

When the frequency inverter sends warning signals, the auxiliary display column displays warning code. Some warnings have no influence on the operation of the inverter. Those warnings which may influence the operation of the frequency inverter should be limited as much as possible; otherwise, more serious failures may be caused. When the frequency inverter fails to alarm, its protective function will act and display fault code and the inverter will stop outputting with the motor freely sliding and shutting down.

### 8.1 TROUBLESHOOTING WITH WARNING OR ALARM DISPLAY

#### 8.1.1 ALARM DISPLAY AND TROUBLESHOOTING

Fault code	Fault description	Possible causes	Solutions
Fu.001	Over current during acceleration	<ol style="list-style-type: none"> <li>1. The acceleration time is too short.</li> <li>2. V/F curve or torque boosting is set improperly.</li> <li>3. After it is re-energized upon transient stop, the rotating motor is restarted.</li> <li>4. The frequency inverter has smaller capacity.</li> <li>5. The encoder is faulty or disconnected during the operation and acceleration with PG.</li> </ol>	<ol style="list-style-type: none"> <li>1. Adjust acceleration time.</li> <li>2. Adjust V/F curve or torque boosting parameters.</li> <li>3. It is valid to set [F0.4.38] as 1; Recover operation in the mode of deceleration and restart after power off.</li> <li>4. Select frequency inverter with matched capacity level.</li> <li>5. Inspect encoder and its connection</li> </ol>
Fu.002	Over current during deceleration	<ol style="list-style-type: none"> <li>1. The deceleration time is too short.</li> <li>2. The potential energy load or load inertia is too large.</li> <li>3. The frequency inverter has smaller capacity.</li> <li>4. The encoder is faulty or disconnected during the operation and deceleration with PG.</li> </ol>	<ol style="list-style-type: none"> <li>1. Adjust deceleration time.</li> <li>2. Connect braking resistor or unit externally.</li> <li>3. Select frequency inverter with matched capacity level.</li> <li>4. Inspect encoder and its connection.</li> </ol>
Fu.003	Over current during operation	<ol style="list-style-type: none"> <li>1. The load changes suddenly.</li> <li>2. The grid has over-low voltage.</li> <li>3. The frequency inverter has smaller capacity.</li> <li>4. The load is overweight.</li> <li>5. After it is re-energized upon transient stop, the rotating motor is restarted.</li> <li>6. The output line of the frequency inverter has interphase short circuit or phase line short circuit to ground.</li> <li>7. The encoder is faulty or disconnected during operation with PG.</li> </ol>	<ol style="list-style-type: none"> <li>1. Reduce load sudden change.</li> <li>2. Inspect voltage of power supply.</li> <li>3. Select frequency inverter with matched capacity level.</li> <li>4. Inspect load or replace a frequency inverter with larger capacity.</li> <li>5. It is valid to set [F0.4.38] as 1; Recover operation in the mode of deceleration and restart after power off.</li> <li>6. Eliminate short circuit failure.</li> <li>7. Inspect the connection of encoder.</li> </ol>

Fault code	Fault description	Possible causes	Solutions
Fu.004	Over voltage during acceleration	<ol style="list-style-type: none"> <li>1. The input voltage is abnormal.</li> <li>2. The rotating speed closed loop parameters are set improperly during vector control operation.</li> <li>3. Start the rotating motor (without rotating speed tracking).</li> </ol>	<ol style="list-style-type: none"> <li>1. Inspect input power supply.</li> <li>2. Adjust rotating speed closed loop parameters. Please refer to the description of F8.1 parameter set.</li> <li>3. It is valid to set [F0.4.38] as 1; Recover operation in the mode of deceleration and restart after power off.</li> </ol>
Fu.005	Over voltage during deceleration	<ol style="list-style-type: none"> <li>1. The deceleration period is too short.</li> <li>2. The load potential energy or inertia is too large.</li> <li>3. The input voltage is abnormal.</li> </ol>	<ol style="list-style-type: none"> <li>1. Adjust deceleration time.</li> <li>2. Connect braking resistor or unit externally.</li> <li>3. Inspect input power supply.</li> </ol>
Fu.006	Over voltage during operation	<ol style="list-style-type: none"> <li>1. The input voltage is abnormal.</li> <li>2. The parameters of regulator are set improperly during vector control operation.</li> </ol>	<ol style="list-style-type: none"> <li>1. Install input reactor.</li> <li>2. For adjusting parameters of regulator, please refer to the description of parameter set in F8.1.</li> </ol>
Fu.007	Over voltage when shutting down	The voltage of the power supply is abnormal.	Inspect voltage of power supply.
Fu.008	Under voltage during operation (can be shielded)	<ol style="list-style-type: none"> <li>1. The voltage of the power supply is abnormal.</li> <li>2. Large load is started in the grid.</li> </ol>	<ol style="list-style-type: none"> <li>1. Inspect voltage of power supply</li> <li>2. Supply power separately</li> </ol>
Fu.011	Electromagnetic interference	False operation caused by the surrounding electromagnetic interference.	Seek for technical service
Fu.012	Overload of frequency inverter	<ol style="list-style-type: none"> <li>1. The load is overweight.</li> <li>2. The acceleration period is too short.</li> <li>3. The booster voltage of torque is too high or V/F curve is set improperly.</li> <li>4. The grid has over-low voltage.</li> <li>5. Do not start rotating speed tracking restart function and directly start the rotating motor.</li> <li>6. In closed loop vector mode, the direction of pulse of the encoder is opposite to that of the motor.</li> </ol>	<ol style="list-style-type: none"> <li>1. Reduce load or replace a frequency inverter with larger capacity.</li> <li>2. Prolong acceleration time.</li> <li>3. Reduce torque lifting voltage and adjust V/F curve.</li> <li>4. Inspect the voltage of grid</li> <li>5. Set the starting/stopping mode ([F0.4.38]) as rotating speed tracking restarting mode.</li> <li>6. Check whether the encoder is reverse.</li> </ol>
Fu.013	Overload protection action of motor	<ol style="list-style-type: none"> <li>1. V/F curve is set improperly.</li> <li>2. The grid has over-low voltage.</li> <li>3. The motor is operated for long time with low speed and large load.</li> <li>4. The overload protection coefficient of the motor is too small.</li> <li>5. Locked-rotor operation of motor or overlarge load.</li> <li>6. In closed loop vector mode, the direction of pulse of the encoder is opposite to that of the motor.</li> </ol>	<ol style="list-style-type: none"> <li>1. Adjust V/F curve.</li> <li>2. Inspect the input voltage of grid.</li> <li>3. Select special motor for frequency conversion for long-term low speed operation.</li> <li>4. Increase the overload protection coefficient of the motor ([F2.0.25]).</li> <li>5. Adjust the working conditions of the load or select frequency inverter with matched capacity level.</li> <li>6. Adjust the connection of encoder or change the function setting for direction of the encoder.</li> </ol>

Fault code	Fault description	Possible causes	Solutions
Fu.014	Overheating of frequency inverter (sensor 1)	<ol style="list-style-type: none"> <li>1. The air duct is blocked.</li> <li>2. The ambient temperature is over high.</li> <li>3. The fan is abnormal.</li> <li>4. The temperature detecting circuit or power module is abnormal.</li> </ol>	<ol style="list-style-type: none"> <li>1. Clean the air duct or improve ventilation conditions.</li> <li>2. Improve ventilation conditions and reduce carrier frequency</li> <li>3. Replace the fan.</li> <li>4. Seek for the manufacturer's support.</li> </ol>
Fu.015	Overheating of frequency inverter (sensor 2)	Same with above.	Same with above.
Fu.016	Overheating of frequency inverter (sensor 3)	Same with above.	Same with above.
Fu.017	External equipment is faulty or the panel has forced stoppage	The external equipment of the frequency inverter is faulty, the input terminal has signal input.	Inspect signal source and relevant equipment and find the root leading to the stoppage of the panel.
Fu.018	Excessive protection of rotating speed deviation	<ol style="list-style-type: none"> <li>1. The load is too large.</li> <li>2. The acceleration time is too short.</li> <li>3. The load is locked.</li> <li>4. The detection value ([F8.2.34]) and time ([F8.2.35]) for DEV is set improperly.</li> </ol>	<ol style="list-style-type: none"> <li>1. Reduce load.</li> <li>2. Prolong acceleration and deceleration time.</li> <li>3. Confirm the mechanical system of the load.</li> <li>4. Reset the detection value ([F8.2.34]) and time ([F8.2.35]) for DEV.</li> </ol>
Fu.019	Over speed failure (OS)	<ol style="list-style-type: none"> <li>1. Overshoot or undershoot is occurred.</li> <li>2. The frequency is too high.</li> <li>3. The detection value ([F8.2.36]) and time ([F8.2.37]) for over speed is set improperly.</li> </ol>	<ol style="list-style-type: none"> <li>1. Adjust the gain.</li> <li>2. Adjust the set value of frequency.</li> <li>3. Reset the set value of the detection value ([F8.2.36]) and time ([F8.2.37]) of OS.</li> </ol>
Fu.020	Reverse connection of A, B pulse	Mistaken connection of A, B pulse of PG card.	<ol style="list-style-type: none"> <li>1. Change the connection order of A, B pulse, or,</li> <li>2. Modify the setting of parameter F8.0.06, or,</li> <li>3. Exchange any two wires from U, V, W</li> </ol>
Fu.021	The master contactor is not actuated well. Or the thruster of major loop is not conducted.	<ol style="list-style-type: none"> <li>1. The DC side master contactor in the frequency inverter is not actuated well.</li> <li>2. The power supply voltage is unstable with frequent sudden change.</li> </ol>	<ol style="list-style-type: none"> <li>1. Clean the dust on the contact of the master contactor.</li> <li>2. Replace the master contactor</li> <li>3. Close this protective function (FF.1.21)</li> </ol>
Fu.022	Internal data memory is faulty	<ol style="list-style-type: none"> <li>1. There is intense noise around in the process of writing in function code data.</li> <li>2. The internal memory is damaged.</li> </ol>	<ol style="list-style-type: none"> <li>1. Retry after reset.</li> <li>2. Seek for manufacturer's service.</li> </ol>

Fault code	Fault description	Possible causes	Solutions
Fu.026 Fu.027 Fu.028	The output current of U phase is deficient/smaller The output current of V phase is deficient/smaller The output current of W phase is deficient/smaller	<ol style="list-style-type: none"> <li>The lead from frequency inverter to motor is disconnected.</li> <li>The driving or control panel of the frequency inverter is faulty.</li> <li>The three-phase winding of the motor is faulty.</li> </ol>	<ol style="list-style-type: none"> <li>Eliminate peripheral failures.</li> <li>Seek for manufacturer's support.</li> <li>Eliminate the failure of motor.</li> </ol>
Fu.032	The three-phase input voltage is unbalanced (can be shielded)	The imbalance rate of three-phase voltage is larger.	<ol style="list-style-type: none"> <li>Add AC or DC reactor.</li> <li>Increase the capacity of frequency inverter.</li> </ol>
Fu.036 Fu.037 Fu.038	A11 input is disconnected A12 input is disconnected A13 input is disconnected	<ol style="list-style-type: none"> <li>The wiring of input analog signal is disconnected or analog input signal source is inexistent.</li> <li>Parameters related to disconnection detection are configured improperly.</li> </ol>	<ol style="list-style-type: none"> <li>Inspect the wiring of analog input signal and the analog input signal source.</li> <li>Modify the configuration parameters.</li> </ol>
Fu.039	Fin input is disconnected	<ol style="list-style-type: none"> <li>The wiring of pulse input signal is disconnected or analog input signal source is inexistent.</li> <li>Parameters related to disconnection detection are configured improperly.</li> </ol>	<ol style="list-style-type: none"> <li>Inspect the wiring of pulse input signal and analog input signal source.</li> <li>Modify the configuration parameters.</li> </ol>
Fu.040	The rotating speed detection loop is disconnected	<ol style="list-style-type: none"> <li>The speed measuring module is incorrectly connected.</li> <li>The wiring of speed measuring module is disconnected.</li> <li>The output of speed measuring module is abnormal.</li> <li>Relevant function codes are set improperly.</li> </ol>	<ol style="list-style-type: none"> <li>Inspect the connection of speed measuring module.</li> <li>Modify the parameter setting.</li> <li>Seek for manufacturer's support.</li> </ol>
Fu.041	The motor fails to be connected when the motor parameters are identified.	The motor fails to be connected when the motor parameters are identified.	Connect motor.
Fu.042	U phase output is disconnected or the parameters are seriously unbalanced	<ol style="list-style-type: none"> <li>The lead from frequency inverter to motor is disconnected.</li> <li>The driving or control panel of the frequency inverter is faulty.</li> <li>The three-phase winding of the motor is faulty.</li> </ol>	<ol style="list-style-type: none"> <li>Eliminate peripheral failures.</li> <li>Seek for manufacturer's support.</li> <li>Eliminate the failure of motor.</li> </ol>
Fu.043	V phase output is disconnected or the parameters are seriously unbalanced	<ol style="list-style-type: none"> <li>The lead from frequency inverter to motor is disconnected.</li> <li>The driving or control panel of the frequency inverter is faulty.</li> <li>The three-phase winding of the motor is faulty.</li> </ol>	<ol style="list-style-type: none"> <li>Eliminate peripheral failures.</li> <li>Seek for manufacturer's support.</li> <li>Eliminate the failure of motor.</li> </ol>

Fault code	Fault description	Possible causes	Solutions
Fu.044	W phase output is disconnected or the parameters are seriously unbalanced	<ol style="list-style-type: none"> <li>1. The lead from frequency inverter to motor is disconnected.</li> <li>2. The driving or control panel of the frequency inverter is faulty.</li> <li>3. The three-phase winding of the motor is faulty.</li> </ol>	<ol style="list-style-type: none"> <li>1. Eliminate peripheral failures.</li> <li>2. Seek for manufacturer's support.</li> <li>3. Eliminate the failure of motor.</li> </ol>
Fu.045	Over temperature of motor	The motor temperature exceeds the setting scope	<ol style="list-style-type: none"> <li>1. Reduce motor load.</li> <li>2. Improve operating environment.</li> <li>3. Modify protective threshold.</li> </ol>
Fu.051	U phase current is detected faulty (sensor or circuit)	<ol style="list-style-type: none"> <li>1. The current sensor or circuit is damaged.</li> <li>2. The auxiliary power supply is faulty.</li> <li>3. The control and driving panel are bad connected.</li> </ol>	Seek for manufacturer's support.
Fu.052	V phase current is detected faulty (sensor or circuit)	<ol style="list-style-type: none"> <li>1. The current sensor or circuit is damaged.</li> <li>2. The auxiliary power supply is faulty</li> <li>3. The control and driving panel are bad connected.</li> </ol>	Seek for manufacturer's support.
Fu.054	The temperature sensor 1 is faulty (can be shielded)	The temperature detecting circuit is abnormal.	Seek for manufacturer's support.
Fu.055	The temperature sensor 2 is faulty (can be shielded)	The temperature detecting circuit is abnormal.	Seek for manufacturer's support.
Fu.056	The temperature sensor 3 is faulty (can be shielded)	The temperature detecting circuit is abnormal.	Seek for manufacturer's support.
Fu.072	The connection of accessories is abnormal	<ol style="list-style-type: none"> <li>1. The extended components are not inserted well.</li> <li>2. The extended components are damaged.</li> </ol>	<ol style="list-style-type: none"> <li>1. Reinstall the extended components.</li> <li>2. Replace the extended components.</li> </ol>
Fu.201	Conflicting parameter setting		Please contact the direct supplier.
Fu.301 ~ Fu.311	Control panel is faulty		Seek for manufacturer's support.

## 8.1.2 WARNING DISPLAY AND TROUBLESHOOTING

Display	Warnings	Can be shielded or not	Solutions other than shielding
aL.003	Over high power supply voltage		Inspect input power supply
aL.008	Lower input voltage (under voltage early warning)		Inspect input power supply
aL.011	Bad electromagnetic environment		Improve working environment or seek for manufacturer's support
aL.012	The load is overweight and protection maybe occurred		Reduce load, or replace a frequency inverter with larger power
aL.014	INV overheating early warning		Improve ventilation conditions and reduce carrier
aL.018	Overlarge DEV		<ol style="list-style-type: none"> <li>1. Reduce load</li> <li>2. Prolong acceleration and deceleration time</li> <li>3. Confirm mechanical system of load</li> <li>4. Confirm the detection value ([F8.2.34]) and time ([F8.2.35]) for DEV</li> </ol>
aL.019	Over speed (OS)		<ol style="list-style-type: none"> <li>1. Adjust frequency setting loop</li> <li>2. Inspect the setting value of detection value [F8.2.36] and time ([F8.2.37]) for OS</li> </ol>
aL.026 aL.027 aL.028	The output current of U phase is deficient/smaller The output current of V phase is deficient/smaller The output current of W phase is deficient/smaller	Can be shielded	Inspect the connecting wire between frequency inverter and motor or the winding of motor
aL.031	The starting enabling signal is deficient		<ol style="list-style-type: none"> <li>1. Inspect the enabling connection (42) in multifunctional input terminal and the status of the terminal (ON/OFF)</li> <li>2. Inspect whether the starting enabling signal in bus command word is effective or not</li> </ol>
aL.032	Early warning of unbalanced three-phase input voltage	Can be shielded	Measure the input voltage of all the phases, install ACR and reduce imbalance rate among phases
aL.036 aL.037 aL.038	AI1 input is disconnected AI2 input is disconnected AI3 input is disconnected	Can be shielded	<ol style="list-style-type: none"> <li>1. Inspect the connection of analog input signal</li> <li>2. Inspect whether there're signals in the signal source</li> </ol>
aL.039	Fin input is disconnected (retained)	Can be shielded	
aL.040	The rotating speed detecting loop is disconnected	Can be shielded	<ol style="list-style-type: none"> <li>1. Inspect the connection of speed measuring module</li> <li>2. Seek for manufacturer's support</li> </ol>
aL.041	No-load operation fails to identify the parameters of motor		

Display	Warnings	Can be shielded or not	Solutions other than shielding
aL.042 aL.043 aL.044	The parameters of U phase of motor is abnormal The parameters of V phase of motor is abnormal The parameters of W phase of motor is abnormal		Inspect whether the winding of motor is faulty
aL.045	Over temperature of motor		Select special motor for frequency conversion for long-term low speed operation
aL.049	The driving circuit is abnormal and unbalanced		
aL.050	The communication of MODBUS bus is interrupted		
aL.054 aL.055 aL.056	The temperature sensor 1 is faulty The temperature sensor 2 is faulty The temperature sensor 3 is faulty	Can be shielded	1. Increase the action point for over temperature warning 2. Replace the temperature sensor 1,2,3
aL.058	The parameters can not be recovered in batch during operation		
aL.059	The numerical value when energized can not be recovered during operation		
aL.061	The connection between expanded communication module and master control board is interrupted abnormally		
aL.062	The function expansion unit 1 has a hardware conflict		1. The expansion unit selected is inappropriate and can not be used with such type of frequency inverter 2. The function expansion unit has a internal fault
aL.063	The function expansion unit 2 has a hardware conflict		1. The expansion unit selected is inappropriate and can not be used with such type of frequency inverter 2. The function expansion unit has a internal fault
aL.064	The function expansion unit has a resource conflict		This expansion unit can not be used with other expansion units
aL.065	Fail to establish communications with function expansion unit 1		
aL.066	Fail to establish communications with function expansion unit 2		
aL.067	The communication links of function expansion unit 1 is interrupted abnormally		



Display	Warnings	Can be shielded or not	Solutions other than shielding
aL.068	The communication links of function expansion unit 2 is interrupted abnormally		
aL.071	The parameter download is failed (Note: download is from operation panel to control panel of frequency inverter; upload is from control panel to operation panel)		Inspect whether the communication interface between operation panel and control panel is normal or not
aL.072	The memory of panel fails to be operated		
aL.073	The memory of panel inhibits write and can not download parameters		
aL.074	The upload of parameters is failed (automatically recover to the numerical value before uploading)		1. Inspect whether the communication interface between panel and control panel is normal or not. 2. In the parameter F0.0.08, parameter upload is forbidden in terms of local upload.
aL.075	The version of panel parameters is different from that of equipment parameters; it can not be uploaded		Re-upload panel parameters same as the version of equipment parameters
aL.076	The panel has no effective parameters and can not be uploaded		The panel parameters are not modified effectively and need not to be uploaded
aL.077	The panel parameters exceed the setting scope INV allowed and fail to be uploaded		Confirm the allowed parameter scope, reset and upload
aL.099	The operation panel is abnormally connected		After power off, reinsert and pull out of the panel or replace the panel
aL.100	The control program is failed resulted from electromagnetic interference		Improve electromagnetic environment
aL.101	The setting parameters are conflicted		Reset the parameters correctly
aL.102	The setting parameters fail to connect the corresponding expansion card		Reset the parameters or inspect the connection of expansion card
aL.103	The setting motor parameters are conflicted(rated frequency, rotating speed conflict)		Reset the motor parameters
aL.104	The setting motor parameters are conflicted (No-load current, rated current, rated rotating speed, rated frequency and rotor time constant)		Reset the motor parameters

Display	Warnings	Can be shielded or not	Solutions other than shielding
aL.105	The inductance parameters of motor stator overflow		Reset the inductance parameters of motors stator
aL.201	The setting parameters are conflicted and it's about to shut down		Immediately contact the direct supplier

## 8.2 ABNORMAL OPERATION WITHOUT PROMPTS AND THE SOLUTIONS

### 1. THE MOTOR IS NOT ROTATED:

Possible causes	Solutions
The operation command channel is wrongly selected	Switch the operation command channel into correct one via PANEL/REMOTE key in operation panel or remote terminal
The operation command source is wrongly selected	According to the need on the site, reset the selection of operation command source ([F0.1.15]), control command 1([F0.3.33]) and control command 2 ([F0.3.34])
The setting frequency is below the starting frequency	<ol style="list-style-type: none"> <li>1. Set the setting frequency to be above the starting frequency ([F0.4.39])</li> <li>2. Inspect whether the frequency setting channel is normal or not, eliminate possible analog input frequency setting failures and shuttle potentiometer failures, etc.</li> <li>3. Correctly connect the external terminals related to frequency setting</li> </ol>
Other frequency command sources with higher priority are valid	According to the need on the site, reset the frequency (rotating speed) setting priority ([F5.3.28])
The upper and lower frequency limit is set improperly.	Inspect the data of upper ([F0.1.21]) and lower ([F0.1.22]) frequency limit and reset
The motor has insufficient torque	<p>In V/F control mode:</p> <ul style="list-style-type: none"> <li>· Increase the torque of motor and boost voltage</li> <li>· Adjust V/F curve</li> </ul> <p>In SVC/VC control mode:</p> <ul style="list-style-type: none"> <li>· Re-measure the parameters of motor ([F2.2.53])</li> <li>· Adjust vector mode and start pre-excitation time ([F2.2.52])</li> </ul>

### 2. THE MOTOR IS ROTATING BUT THE SPEED CAN NOT BE INCREASED:

Possible causes	Solutions
The setting value of maximum output frequency is too low.	Increase the value of maximum output frequency ([F0.1.20]).
The setting value of upper frequency limit is too low.	<ol style="list-style-type: none"> <li>1. Increase the data of upper frequency limit ([F0.1.21]).</li> <li>2. Increase the maximum value of frequency setting channel 1([F0.2.28]) and 2 ([F0.2.31]).</li> </ol>
The set frequency is too low.	Inspect whether the setting of selection of frequency setting channel ([F0.1.16]) is correct or not; the set frequency value is lower or the frequency setting channel is faulty.

Possible causes	Solutions
The acceleration period is too long.	Set appropriate acceleration time ([F1.0.03], [F1.0.05], [F1.0.07], [F1.0.09]).
The parameter values of motor are set improperly	<ol style="list-style-type: none"> <li>1. Confirm whether ([F2.0.00] ~ [F2.0.09]) is compatible with the parameters of motor.</li> <li>2. In vector control mode, make the motor re-self measured and get correct internal motor parameters.</li> </ol>
The output frequency is not rising resulted from current limit protection	<ol style="list-style-type: none"> <li>1. According to the requirements on the site, reasonably configure the acceleration/deceleration current limit level ([F1.4.39]), strong starting current limit level (F1.4.40) and maintenance time ([F1.4.41]).</li> <li>2. Restart after reducing torque and boosting voltage (F1.2.18) and observe whether the output frequency is rising or not.</li> <li>3. Confirm whether V/F setting ([F1.2.15], [F1.2.16], and [F1.2.17]) is appropriate or not. Adjust V/F setting into rated value of motor.</li> </ol>
The output frequency is not rising resulted from torque setting limit	Confirm the torque setting limit ([F8.3.47], [F8.3.48]–[F8.3.51])sets correct value.

### 3. THE DIRECTION OF ROTATION OF THE MOTOR IS OPPOSITE TO THE COMMAND

Possible causes	Solutions
Operation direction	Inspect the setting of operation direction ([F0.1.17]).
The F/R function code in multifunctional input terminal is wrongly selected	Inspect whether the multifunctional input terminal ([F3.0.00]–[F3.0.08]) correctly selects the function code of FWD operation command terminal, REV operation command terminal and three wire operation control.
The action mode of external control terminal is wrongly selected	Inspect the action mode of external control terminal (F0.3.35).
Inspect the wiring connecting with the motor	Exchange the connection of any two phases of U, V, and W of frequency inverter or motor.
Inspect the connection of F/R control terminal	Inspect the connection of multifunctional input terminal set as FWD operation command terminal, REV operation command terminal and three wire operation control.

### 4. ROTATING SPEED VARIATION AND CURRENT FLUCTUATION OCCURS IN CONSTANT SPEED OPERATION

Possible causes	Solutions
The frequency setting varies	When the frequency is set by adopting analog input terminal, the analog input filtering time constant can be increased. ([F4.0.06], [F4.0.07], [F4.0.08])
The carrier frequency is set lower	Increase the carrier frequency of the frequency inverter ([F1.1.13]), change the carrier characteristics ([F1.1.14]) and observe whether the oscillation is disappeared.
The load type is set improperly	Set steady load operation in macro parameter ([F0.0.0]) and confirm whether there's vibration or not.
The motor parameters are set inaccurately	<ol style="list-style-type: none"> <li>1. Make sure the motor parameters ([F2.0.00–F2.0.09]) are set correctly or re-self adjust the internal parameters of the motor.</li> <li>2. Adjust motor speed closed loop PID parameter ([F8.2.25–F8.2.27]).</li> </ol>

Possible causes	Solutions
The wiring between frequency inverter and motor is long	Shorten the output wiring as much as possible or install AC reactor.
Vibration is caused due to the vibration system with lower rigidity at the side of the load	Cancel the increasing of automatic torque, automatic energy-saving operation, anti-overload control, current limit, torque limit and confirm whether the vibration is disappeared.

## 5. THE MOTOR ROARS OR HAS ABNORMAL SOUND

Possible causes	Solutions
The carrier is lower	Increase the carrier frequency of the frequency inverter ([F1.1.13]).
The surrounding temperature of the frequency inverter is higher	<ol style="list-style-type: none"> <li>1. If the temperature exceeds 40°C, it shall strengthen Ventilation and reduce temperature.</li> <li>2. Reduce load and the temperature of frequency inverter (reduce upper frequency limit for fan and pump ([F0.1.21])).</li> <li>3. Select temperature associated adjustment function in carrier characteristics ([F1.1.14]).</li> </ol>
Mechanical resonance	<ol style="list-style-type: none"> <li>1. Operate the motor separately, find the reasons of resonance and improve the characteristics at one side of the motor</li> <li>2. Adjust hopping frequency ([F5.0.00]~[F5.0.05]) and avoid continuous operation in the frequency area where resonance occurs.</li> </ol>
Input phase failure	<ol style="list-style-type: none"> <li>1. Inspect the connection between frequency inverter and motor.</li> <li>2. Inspect whether the three-phase winding of the motor is faulty or damaged.</li> </ol>
The motor parameters are set improperly	Adjust motor speed closed loop PID parameter ([F8.2.25]~[F8.2.27]).

## 6. THE MOTOR DOES NOT ACCELERATE OR DECELERATE WITHIN THE SETTING ACCELERATION AND DECELERATION TIME

Possible causes	Solutions
Operate in the form of S acceleration and deceleration curve	<ol style="list-style-type: none"> <li>1. Set the acceleration and deceleration characteristic parameter ([F1.0.00]) into linear acceleration and deceleration mode and observe the acceleration and deceleration conditions.</li> <li>2. Shorten the acceleration and deceleration time ([F1.0.03]~[F1.0.10]) and observe the acceleration and deceleration conditions.</li> </ol>
Current limit action, the frequency rising is restricted (in acceleration)	<ol style="list-style-type: none"> <li>1. Increase the data of acceleration current limit level ([F1.4.39]) and strong starting current limit level ([F1.4.40]).</li> <li>2. Prolong acceleration time ([F1.0.03], [F1.0.05], [F1.0.07], and [F1.0.09]).</li> </ol>
The motor has insufficient torque	Increase torque and boost voltage ([F1.2.18]) and confirm whether it is started.
The acceleration and deceleration of frequency is limited due to the limitation of torque	<ol style="list-style-type: none"> <li>1. Reset the torque setting limit ([F8.3.47]) and maximum and minimum torque limit value. ([F8.3.48]~[F8.3.51]).</li> <li>2. Prolong acceleration and deceleration time ([F1.0.03]~[F1.0.10]).</li> </ol>
Wrongly select the acceleration and deceleration time	Inspect whether the selection signal for acceleration and deceleration time of multifunctional input terminal ([F3.0.00]~[F3.0.08]) is correct or not.

## 7. AFTER TRANSIENT POWERED OFF, THE MOTOR CAN NOT BE STARTED EVEN IT IS POWERED ON.

Possible causes	Solutions
Restart function after power off (F0.4.48) is prohibited	Set the restart function after transient power off ([F0.4.48]) as valid.
The operation command is maintained in OFF status when it is power on.	Confirm the reset sequence of external circuit, if necessary; discuss whether to adopt the holding relay of operation command.

## 8. THE PARAMETERS ARE SET IMPROPERLY AND THE ORIGINAL VALUE OR DELIVERY VALUE NEEDS TO BE RECOVERED.

Possible causes	Solutions
The function code is conducted unnecessary parameter setting	Recover the parameters not necessary to be set into default.
The function code is conducted wrong parameter setting	Reset necessary function codes after initialization of parameter set as needed and confirm actions.

## 8.3 FAILURES IN SETTING OPERATION OF FREQUENCY INVERTER

### 1. No display in the operation panel

Possible causes	solutions
The operation panel is not correctly connected to the frequency inverter	<ol style="list-style-type: none"> <li>1. Confirm whether the operation panel is correctly connected to the frequency inverter, take it down and reinstall.</li> <li>2. Replace other operation panels and confirm display.</li> </ol>

### 2. The function code can not be changed

Possible causes	Solutions
Some codes can not be changed during operation	Confirm whether it is operating and whether the function code to be changed in the function code list can be changed during operation.
The parameters are locked	Confirm the locking conditions of parameters ([F0.0.05]), ([F0.0.06]); if the parameters are subject to be modified, the locking password with corresponding modification permissions shall be input first.
Did not press OK key	Confirm whether the OK key is pressed after the modification of function code data.
There's failure in the connection between operation panel and frequency inverter	Remove the operation panel and reinstall or replace a new operation panel.



## 8.5 RESET OF WARNING OR ALARM FAILURE

When warning or alarm failure appears, the following operations can be selected:

1. When failure code displays, press **STOP/RESET** key.
2. When external terminal operation command channel is adopted and the terminal for failure reset is defined as valid in multifunctional input terminal Dix, the failures are reset.
3. When the field bus operation command channel is adopted, the upper computer can send fault reset command to frequency inverter through RS485 interface.
4. Power off.



- The failures causes must be checked thoroughly and eliminated before reset, otherwise, the frequency inverter may be damaged permanently.
- If it can not reset or failures reoccur after reset, it should check the causes; continuous reset will damage the frequency inverter.
- The reset shall be conducted 5 minutes later in overload and overheating protection action.
- When external terminals control, the fault reset shall be conducted after the removal of terminal operation command.

## 9. MAINTENANCE

Many factors such as temperature, humidity, dust and vibration of the use environment, and internal components aging, wear of frequency inverter, which may lead to hidden fault of frequency inverter. In order to ensure the frequency inverter of long and steady operation, its maintenance is required in the storage and the process of use.

After long-distance transportation of the frequency inverter, users should check whether the components are in good condition, or the screws are fastened before use them. During the normal use period, users shall regularly clean the internal dust of frequency inverter and check whether the screws are loose.



- The inspection shall be carried out by professional technician, and the power of frequency inverter shall be cut off.
- For frequency inverter with more than half a year storage time, when an electric current is applied, users shall boost the voltage slowly through voltage regulator to supply the power, or otherwise will lead to the risk of electric shock and explosion (internal electrolysis condenser).

Due to the high voltage of frequency inverter in service, the wrong operation can result in serious injury or death, therefore, the power supply of the frequency inverter shall be cut off, and the maintenance operation after ten minutes after the nixie tube of the frequency inverter panel extinguishing can be carried out.

### 9.1 ROUTINE MAINTENANCE

Through routine maintenance, all kinds of abnormal condition and abnormal cause can be found promptly, and the faults and hidden dangers can be eliminated as soon as possible. Thus, the normal operation of equipment can be guaranteed and also the service life of the frequency inverter can be prolonged. Refer to the following table for routine maintenance.

**Table 9-1 Tips for inspection and maintenance**

Object checked	Inspection cycle		Scope of inspection	Assessment criterion
	Irregularly	Regularly		
Operation environment	√		1. Humidity, temperature 2. Dust, moisture 3. Gas	1. Open the frequency inverter when the temperature is above 45°C, keep humidity below 95%, without frost deposit 2. Free from peculiar odor, inflammable and explosive gas
Cooling system		√	1. Installation environment 2. Frequency inverter fan	1. The installation environment shall be well ventilated and the duct has no block 2. Fan is in well operation and without abnormal noise
Frequency inverter	√		1. Vibration, temperature rise 2. Noise 3. Wire, terminal	1. Vibration is smooth and outlet temperature is normal 2. No abnormal noise and no peculiar smell 3. No loose for fastening screw
Generator	√		1. Vibration, temperature rise 2. Noise	1. Smooth operation and normal temperature 2. No abnormalities and inconsistent noise
Input and output parameter	√		1. Input voltage 2. Output current	1. The input voltage is in the specified scope 2. Output current is under the rated value





- Electrical insulation experiment of frequency inverters has been conducted before leaving the factory, and users do not need to conduct the compression test again, or the internal components could be damaged.
- If the frequency inverter is required to undergo the insulation testing, just make sure that all the input and output terminals connected in a reliable way. For a single terminal, insulation testing is strictly prohibited and conduct the test with 500V tramegger
- Do not use tramegger to measure the control circuit. As the frequency inverter has internal static sensitive element, the direct touch is therefore prohibited.
- When conducting the insulation testing for the generator, remove the connection line between generator and the frequency inverter.

## 9.2 INSPECTION AND DISPLACEMENT OF THE VULNERABLE COMPONENTS

During operation, some components of frequency inverter may wear or the performance is slowed down. In order to ensure the stable reliable operation of frequency inverter, the users shall carry out preventative maintenance for frequency inverter, and replace the components when necessary.

### 9.2.1 FILTER CAPACITOR

Possible cause of damage: Environmental temperature and the pulsating current are high, and electrolyte is aging.

Assessment criterion: When frequency inverter operate with load, users check whether there occur fault such as over current, over voltage; whether liquid leaks out, whether the relief valve bulge; whether the determination of electrostatic capacitance and insulation resistance are abnormal.

The pulsating current of main loop would affect the performance of the aluminum electrolysis filter capacitor, and the degree of influence depends on the environment temperature and the using conditions. Replace electrolytic capacitors of frequency inverter every three to four years under normal conditions.

Filter capacitor shall be replaced immediately if any of the following occurs: electrolyte of the electrolyte capacitor leaks, relief valve emits out, and subject of the capacitor expands.

### 9.2.2 COOLING FAN

Possible cause of damage: Bearing wear, leaf aging.

Assessment criterion: When the power of frequency inverter is cut out, check the fan blades and other parts to see whether there is any abnormality such as crack. With the power on, just check whether the fan operation situation is normal, and whether it has abnormal vibration and noise.

Service life of the entire cooling fan in frequency converter is about 15000 hours (i.e. frequency inverter use continuously for about two years), if the fan has unusual voice or vibration, it should be replaced immediately.

### 9.3 STORAGE

After purchase the frequency inverter, if the frequency inverter will be spared for a while or stored for a long time, users shall pay attention to the following items:

- 1) Storage environment should comply with the following table:

Environmental characteristics	Requirements	Remarks
Ambient temperature	-10 °C to 45 °C	Long-term storage temperature is no more than 45 °C, so as to avoid the degradation of capacitance characteristics. It shall avoid condensation and frozen environment caused by sudden change of temperature.
Relative humidity	5 to 95%	It can adopt measurement like plastic film sealing and desiccant.
Storage environment	Free from direct sunlight, no dust, no corrosive, no combustible gas, no oil, no steam, no gas, no drip, no vibration, and with little salt	

- 2) If the frequency inverter is not in use for a long time, the current shall be applied to restore filter capacitor characteristics every half year, and at the same time other features of the frequency converter shall also be checked. When the current is applied, it shall increase the voltage gradually through autotransformer, and the conduction time should be above half an hour.



- If the frequency inverter is not in use for a long time, the internal filter capacitance characteristics would decline.

### 9.4 WARRANTY

If the frequency inverter body has the following cases, the company will provide guarantee service:

- 1) If failures or damages occur in normal use within the warranty period (within 18 months from the date of purchase), our company will provide free maintenance. Our company will charge a reasonable cost of maintenance in case of more than 18 months above.
- 2) Even in the guarantee period, if any failure is caused by the following cases, our company will charge some of the maintenance cost:
  - ✦ Malfunction due to that the users do not operate according to the operation manual or beyond the standard;
  - ✦ Malfunction due to repair and modification without permission;
  - ✦ Malfunction caused by poor preservation;
  - ✦ Malfunction caused by improper use;
  - ✦ Damage to the machine due to fire, corrosive salt, gas corrosion, earthquake, storms, floods, thunder, abnormal voltage or other force majeure.
- 3) The company will provide lifelong paid maintenance services even the warranty period expire.

## 10. EXAMPLE OF USAGE

### 10.1 ENERGY-SAVING TRANSFORMATION OF ESCALATORS

Operating requirements: Activate operation when it senses people approaching and operate a frequency of 50Hz; If there is no input of sensor signal in 10 seconds, it comes that:

Plan 1) automatically stop;

Plan 2) lower the frequency to 20Hz.

#### 10.1.1 SCHEME DESCRIPTION

##### Scheme 1:

1. F0.1.16 = 0 (Factory Default)	Frequency setting channel
2. F0.2.25 = 2 (Factory Default)	Frequency digital setting
3. F0.2.29 = 50.00	Frequency settings
4. F0.3.33 = 1	Select the external terminal control of control commands
5. F0.3.35 = 0002	Three-line model 1
6. F5.1.06 = 1010	Timer 1's clock cycle: 1ms ; Stop- operate trigger-start; state reset of multifunctional terminal; Multi-cycle timing.
7. F5.1.09 = 10000	Timer 1: Cycle reaches 10000ms.
8. F5.1.16 = 0003	Timer 1 outputting signal 1: Cycle reaches 0.5s pulse.
9. F3.0.00 = 7	Multifunctional terminal D11 is defined as FWD operating terminal (to receive sensor signals)
10. FF.0.01 = 55	Virtual output of SDO1 signal - state of D11
11. FF.0.09 = 55	Virtual input of SDI1 signal - timer 1 resets terminals
12. FF.0.02 = 44	Virtual output of SDO2 signal - timer 1's cycle reaches 0.5s pulse.
13. FF.0.10 = 19	Virtual input of SDI2 signal - three-line operates controlling terminal
14. FF.017 = 0010	Phase-reversing connection between SD02 and SDI2

##### Scheme 2:

1. F0.1.16 = 2	Multifunctional terminal selection of frequency settings
2. F0.2.25 = 2	Digital setting of frequency channel 1
3. F0.2.26 = 2	Digital setting of frequency channel 2
4. F0.2.29 = 50	Frequency setting of frequency channel 1
5. F0.2.32 = 20	Frequency setting of frequency channel 2
6. F0.3.33 = 1	External terminal controlling
7. F0.3.35 = 0002	Three-line model 1
8. F3.0.00 = 7	Multifunctional terminal D11 is defined as FWD operating terminal (to receive sensor signals)
9. F5.1.06 = 0000	Timer 1's clock cycle: 1ms ; Operate trigger-start of multifunction terminals; State reset of multifunctional terminal; Single-cycle timing.

10. F5.1.09= 10000	Timer 1: Cycle reaches 10000ms.
11. F5.1.16= 0004	Timer 1 outputting signal 1: Cycle reaches level output.
12. FF.0.01= 55	Virtual output of SDO1 signal - state of DI1
13. FF.0.09= 55	Virtual input of SDI1 signal - timer 1 resets terminals
14. FF.0.02= 44	Virtual output of SDO2 - timer1's cycle reaches the output level signals.
15. FF.0.10= 12	Virtual input of SDI2 signal - change of frequency order
16. FF.0.03= 46	Virtual output of SDO3 signal - timer 2's cycle arrives.
17. FF.0.11= 19	Virtual input of SDI3 signal - three-line operating control
18. FF.0.04= 13	Virtual output of SDO4 - frequency inverter quicken separation
19. FF.0.12= 52	Virtual input of SDI4 signal - timer 1 triggers signal.
20. FF.017= 0100	Phase-reversing connection between SDO3 and SDI3

**10.1.2 WIRING DIAGRAM**

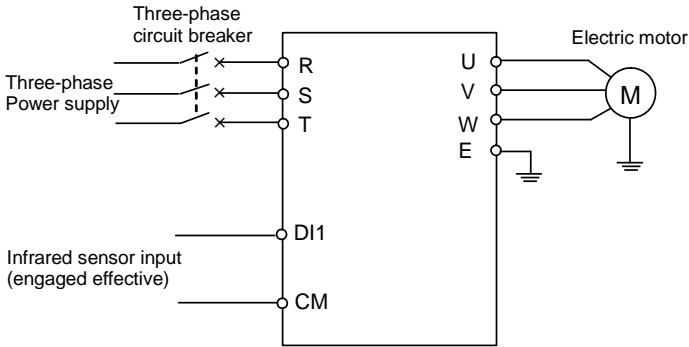

**10.2 MAKE SIMPLE TENSION CLOSED-LOOP CONTROL WITH OFFSET PID**

Use requirements: Frequency inverter adopts closed-loop torque controlling in leather rolling and meets the demand of production rolling. Users only need to make out a torque and a limited speed and then adjust torque output through tension feedback for a constant tension.

Site requirements:

Motor rolling: power: 5.5KW	Rated torque: 36 N.m	Pole number: 2
Tension sensor: Measuring range 0-40N	Signal outputting: 0-10V	
Winding diameter: Diameter of hollow winding 0.5m	Diameter of full winding 1m	

## 10.2.1 DIAGRAM OF CONSTANT TENSION CONTROL

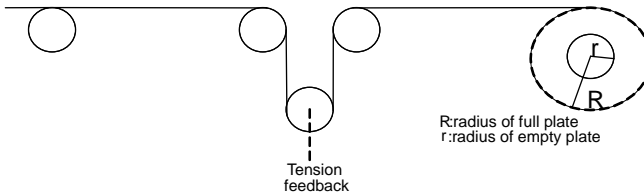

## 10.2.2 DIAGRAM OF CONTROL STRUCTURE

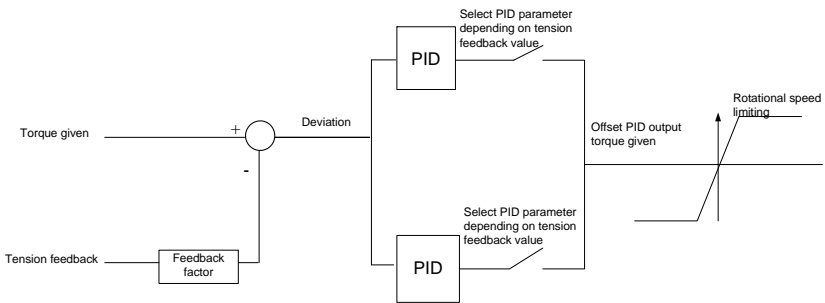

## 10.2.3 CONFIGURATION

- |                   |   |
|-------------------|---|
| 1. F0.0.09= 0010  | Closed-loop vector controlling mode   |
| 2. F8.3.39= 1     | Take care, torque model   |
| 3. F8.3.40= 8     | Torque channel selects offset PID output  |
| 4. F8.3.42= 1     | Time of torque ascending: 1s  |
| 5. F8.3.43= 1     | Time of torque descending: 1s   |
| 6. F8.3.45= 1500  | Positive rotated speed limited set on the basis of motor's actual rated rotated speed   |
| 7. F8.3.46= 1500  | Reverse rotated speed limited set on the basis of motor's actual rated rotated speed  |
| 8. F8.3.47= 0000  | Torque limited channel setup  |
| 9. F8.3.48= -100  | Smallest torque limited: $-K \cdot R \cdot F / T \cdot 100\%$ $R$ : biggest semidiameter $F$ : tension value setting $T$ : torque given $T$ (rated torque of motor output) $= 9550 \cdot P / N$ , $N$ : rotated speed given 100 % $< K < 250\%$ |
| 10. F8.3.50= 100  | Biggest torque limited= $K \cdot R \cdot F / T \cdot 100\%$   |
| 11. F9.0.00= 0101 | Input together of offset PID and frequency inverter Independent PID   |
| 12. F9.0.01= 100  | Offset proportion: $R \cdot F / T$ (rated torque of motor output) %   |
| 13. F9.0.02= 0010 | Offset PID outputs bipolar positive deviation   |
| 14. F9.0.03= 20   | Proportional gain of PID in first part (relatively bigger than parameter value in second part)  |
| 15. F9.0.04= 2    | Integral time of PID in first part (relatively smaller than parameter value in  |

- 16. F9.0.05= 0.2                      second part)                      Differential coefficient of PID in first part
- 17. F9.0.06= 5                        Differential inertia filtering time PID in first part
- 18. F9.0.07= 1                        Offset PID output of Inertia filtering time
- 19. F9.0.08= 0                        Offset PID internal figure setup
- 20. F9.0.11= 62.5                     Offset PID internal figure given=  $(R+r)*F/2T*100\%$
- 21. F9.0.12= 0                        Offset PID feedback selects analog quantity AI1
- 22. F9.0.13= 0                        Feedback input being 0V contrary to 0% feedback
- 23. F9.0.14= 8.3                     Feedback input contrary to 100% feedback=  $Fm*(R+r)/ 2T*10$ , (Fm: full-scale tension value of tension sensor; tension sensor output signal: 0-10V.
- 24. F9.0.15=  $(R + r)/2$               Feedback multiplication factor transform feedback tension signal into torque signal depending on feedback factor
- 25. F9.1.21= 0011                    Offset PID selects double-PID parameter switch PID parameter according to feedback value
- 26. F9.1.23= 0060                    Feedback value of lower-limited switching value 60%
- 27. F9.1.24= 0080                    Feedback value of top-limited switching value 80%
- 28. F9.1.29= 2                        Proportional gain of PID in second part
- 29. F9.1.30= 18                        Integral time of PID in second part
- 30. F9.1.31= 0.5                      Differential coefficient of PID in second part
- 31. F9.1.33= 5                        Regulator output of filtering time constant

**10.2.4 WIRING DIAGRAM**

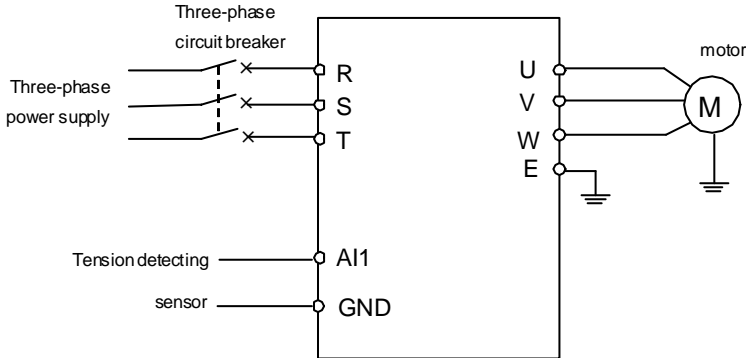

## 10.3 APPLICATION IN MECHANICAL FACTORY

Use requirements: After 50 times' external sensor signal receiving, operate the frequency inverter with first step from 20Hz to 20s forwardly and second step from 30Hz to 40s reversely. Then make a stop and wait for the next operation.

### 10.3.1 CONFIGURATION

1. F0.3.33= 1	Controlling order to be the external terminal controlling
2. F0.3.35= 0002	Function model of external controlling terminal to be the three wire model 1
3. F1.0.03= 5	Time for accelerating: 5s
4. F1.0.04= 5	Time for slowing down: 5s
5. F3.0.00= 44	DI1 terminal id defined as timer 1's clock terminal
6. F5.2.20= 0100	Select timer 1 work model
7. F5.2.22= 50	Set number counting as 50
8. F6.0.00= 20	Set first velocity as 20Hz
9. F6.0.01= 30	Set second velocity as 30Hz
10. F6.1.15= 0011	Operation model selects the stop model of multi-velocity single cycle
11. F6.1.17= 0010	Set operating direction in second velocity as the reverse
12. F6.1.31= 20	Time running for first velocity: 20s
13. F6.1.32= 40	Time running for second velocity: 40s
14. FF.0.01= 40	Virtual output of SDO1 signal — timer 1's cycle arrives
15. FF.0.09= 7	Virtual input of SDI1 signal — positive shift FWD terminal
16. FF.0.02= 46	Virtual output of SDO2 signal — timer 2's cycle arrives.
17. FF.0.10= 19	Virtual input of SDI2 signal — three-line operating control
18. FF.0.17= 0010	Phase-reversing connection between SDO2 and SDI2

### 10.3.2 EXTERNAL CIRCUIT WIRING DIAGRAM

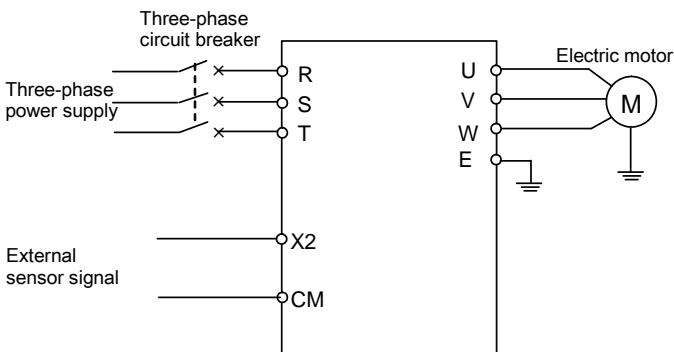

## 10.4 MULTI-PID SETUP, MULTI-PART PID SETUP, FORM A MULTI-STEP PIDSETUP (TO REDUCE OVERSTRIKE)

### 10.4.1 PARAMETER SETUP

1. F6.1.15= 0053	Multi-part PID operating input (keep the final value stop model)
2. F6.1.31= 1	Time for operating in part 1: 1s
3. F6.1.32= 1	Time for operating in part 2: 1s
4. F6.1.33= 1	Time for operating in part 3: 1s
5. F6.1.34= 1	Time for operating in part 4: 1s
6. F6.1.35= 1	Time for operating in part 5: 1s
7. F6.1.36= 1	Time for operating in part 6: 1s
8. F6.1.37= 5	Time for operating in part 7: 5s
9. F7.0.00= 0001	Process PID input without requirements
10. F7.0.13= 10	100% feedback corresponding simulation: 10V
11. F7.0.17= 15.85	Proportional gain: 15.85
12. F7.0.18= 14	INTEGRAL time: 14
13. F7.1.27= 10	Part 1 in process PID given with 10%
14. F7.1.28= 20	Part 2 in process PID given with 20%
15. F7.1.29= 30	Part 3 in process PID given with 30%
16. F7.1.30= 40	Part 4 in process PID given with 40%
17. F7.1.31= 50	Part 5 in process PID given with 50%
18. F7.1.32= 60	Part 6 in process PID given with 60%
19. F7.1.33= 80	Part 7 in process PID given with 70%

### 10.4.2 DIAGRAM OF STEP PID VALUE GIVEN

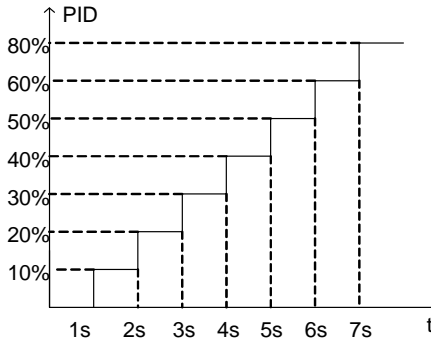



# 11. DESCRIPTION OF COMMUNICATION PROTOCOL

## 11.1 MODBUS PROTOCOL DESCRIPTION

### 11.1.1 PROTOCOL OVERVIEW

Modbus protocol is a universal protocol used in the industrial control unit. Because this protocol can be conveniently applied, this protocol has been considered as the general industry standard and is widely applied to the integrated system of master controllers and slave units. By applying this protocol, units of various brands can be connected together and functioning as an industrial network.

Modbus defines three types of transmission modes: ASCII, RTU and TCP. **V560** Frequency inverter only supports RTU mode.

### 11.1.2 INTERFACE AND TRANSMISSION METHOD

**V560** utilizes RS485 (RS232, optional, which has to be converted by a level) as the physical interface for Modbus, and one host can control one or more (maximum 247 units) frequency inverters.

Terminal Identifier	Terminal Usage	Function
RS+	Data Transceiving Terminal(+)	When connected to PC/PLC via RS 485 communication interface, connect to (+) signal
RS-	Data Transceiving Terminal(-)	When connected to PC/PLC via RS 485 communication interface, connect to (-) signal

By applying the asynchronous serial half-duplex transmission method, only master unit or slave unit can transmit data at one particular moment, and the other unit can only receive data.

### 11.1.3 DATA STRUCTURE

- 1) 4 Optional Data Transmission Formats
  - 1 start bit, 8 data bits, 1 stop bit, without parity bit (factory setting)
  - 1 start bit, 8 data bits, 1 stop bit, even parity
  - 1 start bit, 8 data bits, 1 stop bit, odd parity
  - 1 start bit, 8 data bits, 2 stop bit, without parity bit

- 2) Baud rate

Seven optional baud rates: 1200bps, 2400 bps, 4800 bps, 9600 bps, 19200 bps, 38400bps, 79600 bps

- 3) Communication rules

Starting interval between data frames is longer than 3.5 byte transmission cycle (standard), but the minimum interval should not be shorter than 0.5 ms.

### 11.1.4 PARAMETER CONFIGURATION FOR FREQUENCY INVERTERS

FA.0.00 is a read-only parameter, and is used to display the status of the communication card connection and bus;

FA.0.01 = 00XX, unit digit is used to choose baud rate, and tens digit is used to choose data format;

FA.0.02 = X, choose the address of this station;

FA.0.03–FA.0.06, configure supporting communication parameters; refer to functional parameter table for detailed functions.



- X indicates that this digit can be any value in the allowed range.

## 11.1.5 BRIEF INTRODUCTION OF FUNCTIONS

The Modbus functional codes supported by V560 are listed below:

Function	Code (Hexadecimal)	Description of Functions
Read coil status	0x01	Read coil status by digit. Each digit for the controlling character is mapped to coil 0~15 respectively.
Read discrete input status	0x02	Read discrete input status. Each digit for the status character is mapped to coil 0~15 respectively.
Read multiple hold registers	0x03	Read multiple hold registers. It can read all the application parameters, status parameters, controlling characters, status characters and setting values of V560.
Read multiple input registers	0x04	Read multiple input registers. The address for analog input register starts from 0x1200.
Enforce single coil	0x05	Perform writing action for a single output digit. Each digit for the controlling character is mapped to coil 1~16 respectively.
Write to a single hold register	0x06	Perform writing action for a single hold register. All the parameters, controlling characters, status characters and setting values of V560 are mapped to the hold register.
Query for the anomaly status	0x07	Query for the anomaly status information. In V560, the failure information of the frequency inverter can be queried.
Failure diagnosis	0x08	Execute field diagnosis for the bus failure. Support the sub-codes, like querying (0x00), rebooting (0x01), monitoring (0x04) and zero-clearing(0x0A) etc.
Enforce multiple coils	0x0F	Perform writing action for multiple output digits respectively. Each digit for the controlling character is mapped to coil 1~16 respectively.
Write to multiple hold registers	0x10	Perform writing action for multiple hold registers. All the parameters, controlling characters, status characters and setting values of V560 are also mapped to the hold register.
Read/write to multiple hold registers	0x17	This function equals to combining 0x03 and 0x10 into a new command.

## 11.1.6 ACCESS ADDRESS SUMMARY

V560	Access Address	Functional Codes Supported (Hexadecimal)
Controlling digit Multi-purpose terminal output Relay output	Coil (0x1000-0x1100)	0x01- Read coil status 0x05- Enforce single coil 0x0F- Enforce multiple coils
Multi-purpose terminal input for status digit	Discrete input (0x1100-0x1200)	0x02- Read input status
Analog input	Input register (0x1200-0x1300)	0x04- Read input register
Application parameters Status parameters Controlling characters, Status characters Setting values Mapping status parameters Mapping application parameters	Hold registers (application parameter area, status parameter area, 0x1300-0x1400)	0x03- Read multiple registers 0x06- Write to a single register 0x10- Write to multiple registers 0x17- Read/write to multiple registers

For detailed address distribution, please refer to below section of Modbus detailed address-finding distribution.

## 11.1.7 DETAILED MODBUS ADDRESS-FINDING DISTRIBUTION

### 1) Coil Address Summary (0x1000-0x1100)

Relevant Modbus functional codes: 0x01 (read coil status), 0x05 (write to a single coil), 0x0F (write to multiple coils)

Register name	Function Description	Access Address
Controlling Digit – Digit 0	Keep	0x1000
Controlling Digit – Digit 1	Operation Allowed 0: Operation banned      1: Operation allowed	0x1001
Controlling Digit – Digit 2	Starting allowed 0: Starting banned      1: Starting allowed	0x1002
Controlling Digit – Digit 3	Keep	0x1003
Controlling Digit – Digit 4	Operation instruction 0: Stop      1: Operation	0x1004
Controlling Digit – Digit 5	Operation direction 0: Positive      1: Negative	0x1005
Controlling Digit – Digit 6	Emergency Stop 0: Invalid      1: Valid	0x1006
Controlling Digit – Digit 7	Free slide stop    0: Invalid    1: Valid	0x1007
Controlling Digit – Digit 8	Keep	0x1008
Controlling Digit – Digit 9	Keep	0x1009
Controlling Digit – Digit 10	Keep	0x100A
Controlling Digit – Digit 11	Keep	0x100B
Controlling Digit – Digit 12	Acceleration/deceleration banned 0: Allowed      1: Banned	0x100C
Controlling Digit – Digit 13	Zero-clearing for integrator input 0: Invalid      1: Valid	0x100D
Controlling Digit – Digit 14	Remote Control 0: Invalid      1: Valid	0x100E
Controlling Digit – Digit 15	Failure Reset      0- >1 Reset	0x100F
DO1	Multi-purpose output terminal 1	0x1020
DO2	Multi-purpose output terminal 2	0x1021
EDO1	Multi-purpose output terminal 3 (extendable card)	0x1030
RO1	Multi-purpose relay output 1	0x1040
ERO1	Multi-purpose relay output 2 (extendable card)	0x1050
Keep		0x1051– 0x1099

## 2) Discrete Input Address Summary (0x1100 ~ 0x1200)

Relevant Modbus functional codes: 0x02 (read input status)

Register name	Function Description	Access Address
Status Character – Digit 0	Ready	0x1100
Status Character – Digit 1	Operation allowed	0x1101
Status Character – Digit 2	Starting allowed	0x1102
Status Character – Digit 3	Keep	0x1103
Status Character – Digit 4	Operation status	0x1104
Status Character – Digit 5	Direction	0x1105
Status Character – Digit 6	Zero speed	0x1106
Status Character – Digit 7	Acceleration	0x1107
Status Character – Digit 8	Deceleration	0x1108
Status Character – Digit 9	Arrival	0x1109
Status Character – Digit 10	Keep	0x110A
Status Character – Digit 11	Keep	0x110B
Status Character – Digit 12	Instruction source	0x110C
Status Character – Digit 13	Command source	0x110D
Status Character – Digit 14	Warning	0x110E
Status Character – Digit 15	Failure	0x110F
DI1	Multi-purpose input terminal 1	0x1120
DI2	Multi-purpose input terminal 2	0x1121
DI3	Multi-purpose input terminal 3	0x1122
DI4	Multi-purpose input terminal 4	0x1123
DI5	Multi-purpose input terminal 5	0x1124
DI6	Multi-purpose input terminal 6	0x1125
EDI1	Multi-purpose input terminal 7 (extendable card)	0x1130
EDI2	Multi-purpose input terminal 8 (extendable card)	0x1131
EDI3	Multi-purpose input terminal 9 (extendable card)	0x1132
Keep		0x1133–0x1199

## 3) Input Register Address Summary (0x1200 ~ 0x1300)

Relevant Modbus functional codes: 0x04 (read input register)

Register name	Function Description	Value Range	Access Address
AI1	Analog input value 1	0 ~ 4080	0x1200
AI2	Analog input value 2	0 ~ 4080	0x1201
AI3	Analog input value 3 (extendable card)	0 ~ 4080	0x1202
Fin	Pulse input value (extendable card)	0 ~ 4080	0x1203
Keep			0x1204~0x1299

## 4) Hold Register Address Summary

Relevant Modbus functional codes: 0x03 (read multiple registers), x06 (write to multiple registers), 0x10 (write to multiple registers), 0x17 (read/write to multiple registers).

**Application parameter address**

The application parameter access address can be obtained from the parameter's identifier when ascertaining the access address, the method is to ignore the sub-class code in the identifier (following referred to as ""); let's see an example, for parameter identifier: HH.\*.DD (e.g.F2.0.33), it will obtain HHDD directly (hexadecimal format), and the access address for F2.0.33 is: 0xF233H. Below attached is the table for respective conversion of access addresses:

Parameter identifier	RAM Access Address ①	ROM Access Address
F0.#.00 ~ F0.#.55	0xF000~0xF055	0xE000~0xE055
..... *	...	...
F9.#.00 ~ F9.#.55	0xF900~0xF955	0xE900~0xE955
FA.#.00 ~ FA.#.55	0xFA00~0xFA55	0xEA00~0xEA55
..... *	...	...
FF.#.00 ~ FF.#.55	0xFF00~0xFF55	0xEF00~0xEF55
dE.#.00 ~ dE.#.55 (read-only)	0xDE00~0xDE55	0xBE00~0xBE55

**Status parameter address (read-only):** The address conversion method for status parameter is similar to that for application parameter. However, there is no ROM access address.

Parameter Identifier	RAM Access Address
d0.#.00 ~ d0.#.55	0xD000~0xD055
d1.#.00 ~ d1.#.55	0xD100~0xD155

**Bus Controlling Parameter Address (0x1300 ~ 0x1400)**

Register Name	Value Range	Access Address
Controlling character (mapping coils 0-15) ②	0 ~ 0xFFFF	0x1300
Modbus setting value 1 (Relative Value) ③	-10000 ~ 10000	0x1301
Modbus setting value 2 (Absolute Value)	-30000 ~ 30000	0x1302
Mapping application parameters 1 ④	[F0.00 ~ FF.55]	0x1303
Mapping application parameters 2	[F0.00 ~ FF.55]	0x1304
Mapping application parameters 3	[F0.00 ~ FF.55]	0x1305
Mapping application parameters 4	[F0.00 ~ FF.55]	0x1306
Mapping application parameters 5	[F0.00 ~ FF.55]	0x1307
Mapping application parameters 6	[F0.00 ~ FF.55]	0x1308
Status Character (Mapping discrete range 0-15)	0 ~ 0xFFFF	0x1309
Mapping status parameters 1	[d0.00 ~ d1.49]	0x130A
Mapping status parameters 2	[d0.00 ~ d1.49]	0x130B
Mapping status parameters 3	[d0.00 ~ d1.49]	0x130C
Mapping status parameters 4	[d0.00 ~ d1.49]	0x130D
Mapping status parameters 5	[d0.00 ~ d1.49]	0x130E
Mapping status parameters 6	[d0.00 ~ d1.49]	0x130F
Mapping status parameters 7	[d0.00 ~ d1.49]	0x1310
Mapping status parameters 8	[d0.00 ~ d1.49]	0x1311
Mapping status parameters 9	[d0.00 ~ d1.49]	0x1312
Mapping status parameters 10	[d0.00 ~ d1.49]	0x1313
Keep	Undefined	0x1314 ~0x1400

**Notes:**

- If there is no need to keep the parameters permanently, it suffices to write the parameters to the RAM area. However, if the parameters have to be maintained permanently, it is required to write the parameter values into the ROM area. The service life of ROM area will be shortened if parameters are frequently written to the ROM area. If value F2.1.13 needs to be written and maintained permanently, the register address where it should be written to is 0xE213.
- When reading/writing controlling characters, it can be achieved via reading/writing to the coil mapped to each digit of controlling characters, and it can also be achieved via reading/writing to the hold register corresponding to the controlling characters. Both methods can achieve identical results. If it is needed to set the value for operation allowed, we can set the value of the digit 1 for controlling character (address 0x1001) as 1 Via functional code 05, we can also set the value of controlling character (address 0x1300) as 0x0002 via functional code 06. When reading the status characters, the method is similar to that for reading/writing controlling characters. It can be achieved via reading the discrete input mapped to each digit of status characters, and it can also be achieved via reading the hold register corresponding to the status characters. If we need to read the operation direction, we can read the status digit 5 (address 0x1105) via functional code 02, we can also read the status character (address 0x1309) via functional code 03.

- Range for relative values is between -10000 ~ 10000, and correspondingly, they falls in -100.00%~100.00% range of the upper limit value that has been set.
- When we need to access several application parameters or monitoring parameters of discrete addresses, we can first map these parameters to bus control parameter area, and then we access to that area instead. As a matter of fact, access for mapped parameters is a type of pointer access, and the mapping parameters can be set in the FA.1 parameter group.
- Anomaly Status Information: Relevant Modbus functional code 0x07 (Query)
 

The frequency inverter's failure warning status and code corresponding to each digit of the returned data

Returned data – digit 7: 0 — No failure on frequency inverter, 1 — Failure on frequency inverter

Returned data – digit 6: 0 — No warning on frequency inverter, 1 — Warning on frequency inverter

Returned data – digit 5-0: each code of failure information corresponds to the identifier code following Fu in the failure code of the frequency inverter.

Each code of warning information corresponds to the identifier code following aL. in the warning code of the frequency inverter.

If data 0x8C (10001100) is returned, it indicates that the failure code of the frequency inverter is Fu. 012;

If data 0x64 (01100100) is returned, it indicates that warning code of the frequency inverter is aL.036.
- Failure Diagnosis: Relevant Modbus functional code 0x08 (Diagnosis)

## Sub-function code list

Sub-function code	Function	Query Data	Response Data
00	Return the identical query data	Random	Image query data
01	Re-start communication option (restore the "listen only" status for 04 sub-code)	FF00/0000	FF00/0000
04	Enforce slave unit into "Listen Only" status and the slave unit will not reply; The failed slave unit can be removed from the communication chain.	0000	No reply
0A	Clear all calculators and diagnosing registers	0000	Image query data
0B	Return the number of bus information items	0000	Total number of bus information items
0C	Return the number of bus communication failures (CRC error calculation)	0000	CRC error calculation
0D	Return the number of bus anomaly failures	0000	Number of anomaly data items
0E	Return the number of slave unit information items (corresponding with slave unit address or the broadcasting information)	0000	Number of valid data items

### 11.1.8 EXAMPLES

#### 1) Start 1# Frequency inverter Operation

Host request:

Slave Unit Address	Function Code	Coil Starting Address High Digit	Coil Starting Address Low Digit	Write Values High Digit	Write Values Low Digit	CRC Check Low Digit	CRC Check High Digit
01	05	10	04	FF	00	C9	3B

Slave Unit Response: Frequency inverter will operate in positive direction, and return the identical data as requested by the host.

#### 2) Set the operation frequency as 25.00Hz for frequency inverter, and correspondingly, it is 50.00% of the upper limit frequency 50.00 Hz.

Host request:

Slave Unit Address	Function Code	Register Starting Address High Digit	Register Starting Address Low Digit	Register Data High Digit	Register Data Low Digit	CRC Check Low Digit	CRC Check High Digit
01	06	13	01	13	88	D1	D8

Slave Unit Response: Set the value for frequency inverter's frequency as 25.00Hz, and return the identical data as requested by the host.

#### 3) Return the frequency inverter's current operational frequency and rotation speed, the positive rotating frequency of frequency inverter is 50.00Hz, and positive rotation speed of the electrical motor is 1500rpm.

Host request:

Slave Unit Address	Function Code	Register Starting Address High Digit	Register Starting Address Low Digit	Number of Registers High Digit	Number of Registers Low Digit	CRC Check Low Digit	CRC Check High Digit
01	03	D0	00	00	02	FC	CB

Slave Unit Response:

Slave Unit Address	Function Code	Number of bytes read	The 1st register data high digit	The 1st register data low digit	The 2nd register data high digit	The 2nd register data low digit	CRC Check Low Digit	CRC Check High Digit
01	03	04	13	88	05	DC	7C	54

#### 4) Query the number of bus communication failures (CRC error calculation), return the number of bus communication failure as 35.

Host request:

Slave Unit Address	Function Code	Sub-function Code High Digit	Sub-function Code Low Digit	Query data High Digit	Query data Low Digit	CRC Check Low Digit	CRC Check High Digit
01	08	00	0C	00	00	20	08



Slave Unit Response:

Slave Unit Address	Function Code	Sub-function Code High Digit	Sub-function Code Low Digit	Response Data High Digit	Response Data Low Digit	CRC Check Low Digit	CRC Check High Digit
01	08	00	0C	00	23	61	D1

5) Query the model description for frequency inverter

Host request:

Slave Unit Address	Function Code	CRC Check Low Digit	CRC Check High Digit
01	11	C0	2C

Slave Unit Response:

Slave Unit Address	Function Code	Number of Bytes	Model Data	Operation Status	Extra Data	CRC Check Low Digit	CRC Check High Digit
01	11	10	00 00 01 05 60	FF	04 03 11 00 20 11 01 02 61 02	A5	5C

Model of frequency inverter: V560-4T1100G/4T1320P, frequency inverter in operation, production batch of 2011-2-3, version number: 6201.

## Chapter 12 EMC

### 12.1 CE

The product can be sold freely in the market of EEA (European Economic Area) with CE label, and to be ensured to meet other requirements as LVD and EMC.

### 12.2 DEFINITION

EMC (Electromagnetic Compatibility) means the capacity of anti-interference for electric and electron equipments, and the product could not interfere other local equipments also. EMC rules are defined requirements of anti-interference for EU area.

- 1) 1<sup>st</sup> Environment: including power supply equipments of civil low voltage grid.
  - 2) 2<sup>nd</sup> Environment: including power supply equipments of non-civil low voltage grid.
- C1 Inverter: when rated power of electric transmission system is under 1000V, use in 1<sup>st</sup> environment.
  - C2 Inverter: when rated voltage of electric transmission system is under 1000V, it would be plug equipments or mobile equipments. When it uses in 1<sup>st</sup> environment, it should install and adjust by professional engineer.
  - C3 Inverter: when rated voltage of electric transmission system is under 1000V, it is suitable in 2<sup>nd</sup> environment, but not 1<sup>st</sup> environment.
  - C4 Inverter: when rated voltage of electric transmission system is not under 1000V or rated current is not lower than 400A, or it is suitable in complicated system of 2<sup>nd</sup> environment.

### 12.3 OBEY STANDARD ORDER

#### 12.3.1 OBEY EMC ORDER

V560 Series meet the requirements of standard EN61800-3: 2004 C2, which is suitable in 1<sup>st</sup> and 2<sup>nd</sup> environment.

#### 12.3.2 OBEY LVD ORDER

V560 Series meet the requirements of standard EN 61800-2.

Installation of 1<sup>st</sup> environment:

- 1) Inverter chooses suited EMC filter.
- 2) Select suitable motor and wires.
- 3) Wiring according to 《Cable Wiring Requirements》.
- 4) Max output cable length is 100m.



➤ Warning: If inverter is using in residence or civil area, it would cause electromagnetic interference. Except CE requirements, user should take some necessary action to avoid this interference.

## 12.4 GUIDANCE OF EMC EXTERNAL ACCESSORIES INSTALLATION AND SELECTION

External EMC input filter between inverter and power supply is not only to restrain interference to inverter by ambient electromagnetic noise, and to avoid interference to ambient equipments by inverter. In order to meet standard of C2 level, it should add external suitable EMC filter on inverter input terminal.

### 12.4.1 NOTICE OF EMI INPUT FILTER INSTALLATION:

Please obey rated values for using the filter. Because filter is type I electrical equipment, filter metal shell should contact well with installation cabinet metal with good Conductive continuity. Otherwise, it would cause the risk of electric shock and affect EMC efficiency badly. The earth of filter and inverter PE terminal must earth on same GND. If not, it will affect EMC efficiency badly. Please contact our technical support for EMI filter selection and installation.

### 12.4.2 DC REACTOR

DC Reactor is mainly used in inverter and rectifying for increasing power factor and filtering interference of stripe, voltage, current, and decreasing inverter harmonic interference.

1, Performance Index of DC Reactor

- 1) Rated working voltage: DC 500V~DC540V;
- 2) Dielectric strength: iron core-winding 2500VAC/50Hz/5mA/60S, no flashover breakdown;
- 3) Insulation Resistance: iron core-winding 500VDC, insulation resistance  $\geq 100M\Omega$ ;;
- 4) Reactor noise is lower than 65dB (test at the point of 1m horizontal distance with reactor)
- 5) Temperature rise is less than 70K

## 2, Parameter Configuration of DC Reactor

Inverter Power (KW)	Reactor Model	Size L*W*H (mm)	Mounting Dimension (mm)	Terminal Aperture (mm)
0.7	DLK-3A	80*65*110	63*60	Φ4
1.1	DLK-6A	80*85*110	63*60	Φ4
1.5	DLK-6A	80*85*110	63*60	Φ4
2.2	DLK-6A	80*85*110	63*60	Φ4
3.0	DLK-12A	100*100*125	80*70	Φ4
4.0	DLK-12A	100*100*125	80*70	Φ4
5.5	DLK-23A	110*120*135	87*70	Φ4
7.5	DLK-23A	110*120*135	87*70	Φ4
9.0	DLK-33A	110*120*135	87*70	Φ4
11	DLK-33A	110*120*135	87*70	Φ4
15	DLK-33A	110*120*135	87*70	Φ4
18.5	DLK-40A	110*120*135	87*70	Φ5
22	DLK-50A	120*135*145	95*85	Φ5
30	DLK-65A	138*150*170	111*85	Φ5
37	DLK-78A	138*150*170	111*85	Φ5
45	DLK-95A	138*150*170	111*85	Φ6
55	DLK-115A	155*160*195	125*90	Φ6

### 12.4.3 INPUT REACTOR

AC input reactor is mounted at input terminal of inverter to restrain transmitting harmonic generated by inverter to power grid, reduce interference of inverter harmonic to other components, improve quality of power grid, improve power factors and restrain abnormal fluctuations of power grid voltage and surge current of power grid, stabilize waveform and reduce impact to inverter.

#### 1, Performance index of AC input reactor

- Rated operational voltage: 380V/50Hz;
- Dielectric strength: iron core-winding 3000VAC/50Hz/5mA/60S, no flashover breakdown;

- Insulation resistance: iron core-winding 1000VDC, insulation resistance  $\geq 100M\Omega$  ;
- Reactor noise is less than 70dB (test at the point of 1m horizontal distance with reactor);
- Temperature rise is less than 70K.

## 2, Parameter Configuration of AC Input Reactor

Inverter Power (KW)	Reactor Model	Size L*W*H (mm)	Mounting Dimension (mm)	Installation Terminal Aperture (mm)
0.7	AKSG10A/5V	140*85*140	75*55	Φ6
1.1	AKSG10A/5V	140*85*140	75*55	Φ6
1.5	AKSG10A/5V	140*85*140	75*55	Φ6
2.2	AKSG10A/5V	140*85*140	75*55	Φ6
3.0	AKSG10A/5V	140*85*140	75*55	Φ6
4.0	AKSG15A/5V	140*85*140	75*55	Φ6
5.5	AKSG15A/5V	140*85*140	75*55	Φ6
7.5	AKSG20A/5V	175*130*140	82*75	Φ6
9.0	AKSG30A/5V	175*130*140	82*75	Φ6
11	AKSG30A/5V	175*130*140	82*75	Φ6
15	AKSG40A/5V	210*120*190	110*70	Φ8
18.5	AKSG50A/5V	210*120*190	110*70	Φ8
22	AKSG60A/5V	210*165*170	110*85	Φ8
30	AKSG80A/5V	210*165*170	110*85	Φ8
37	AKSG110A/5V	210*165*170	110*85	Φ8
45	AKSG125A/5V	210*165*170	110*85	Φ8
55	AKSG150A/5V	270*170*220	155*85	Φ10

### 12.4.4 AC OUTPUT REACTOR

AC output reactor is mounted at output terminal of inverter to restrain capacitive charging current of connecting cable between inverter and motor, voltage built-up rate of PWM wave of passivated inverter, improve power factor and quality of power grid as well as stabilize waveform.

## 1, Performance index of AC output reactor

- Rated operational voltage: 380V/50Hz;
- Dielectric strength: cored winding 3000VAC/50Hz/10mA/60S, no flashover breakdown;
- Insulation resistance: cored winding 1000VDC, insulation resistance  $\geq 100M \Omega$  ;
- Reactor noise is less than 65dB (test at the point of 1m horizontal distance with reactor).

## 2, Parameter Configuration of AC Output Reactor

Inverter Power (KW)	Reactor Model	Size L*W*H (mm)	Mounting Dimension (mm)	Terminal Aperture (mm)
0.7	AKSG10A/9V	140*85*140	75*55	
1.1	AKSG10A/9V	140*85*140	75*55	$\phi 6$
1.5	AKSG10A/9V	140*85*140	75*55	$\phi 6$
2.2	AKSG10A/9V	140*85*140	75*55	$\phi 6$
3.0	AKSG10A/9V	140*85*140	75*55	$\phi 6$
4.0	AKSG15A/9V	140*85*140	75*55	$\phi 6$
5.5	AKSG15A/9V	140*85*140	75*55	$\phi 6$
7.5	AKSG20A/9V	140*85*140	75*55	$\phi 6$
9.0	AKSG30A/9V	210*165*170	110*85	$\Phi 8$
11	AKSG30A/9V	210*165*170	110*85	$\Phi 8$
15	AKSG40A/9V	210*165*170	110*85	$\Phi 8$
18.5	AKSG50A/9V	210*165*170	110*85	$\Phi 8$
22	AKSG60A/9V	210*165*170	110*85	$\Phi 8$
30	AKSG80A/9V	270*190*230	155*100	$\Phi 10$
37	AKSG110A/9V	270*190*230	155*100	$\Phi 10$
45	AKSG125A/9V	270*190*230	155*100	$\Phi 10$
55	AKSG150A/9V	290*200*230	170*115	$\Phi 10$

## 12.5 SHIELDED CABLE

In order to meet EMC requirements of CE, it must use shielded cable with shielded layer. Shielded cable has 3 phase conductive shielded cable and 4 phase conductive shielded cable. If conductive performance of shielded layer cannot meet requirement, it would add one separate PE wire or use 4 phase conductive shielded cable with one PE wire.

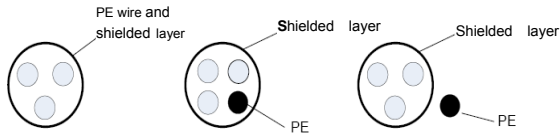

In order to restrain shooting and conducting of radio frequency effectively, shielded layer of shielded cable makes up of coaxial copper intertexture. For increasing shielding efficiency and conductive performance, intertexture density of shielded layer should be more than 90%.

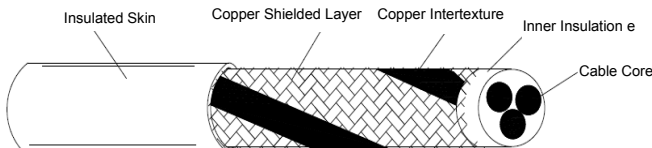

## 12.6 CABLE WIRING REQUIREMENTS

- 1) Wiring of motor should be far from other cable wirings, and cable of several inverter motors can be wiring side by side.
- 2) Wiring of motor cable, input drive cable and control cable would be in different wire casing. In order to avoid electromagnetic interference of inverter output voltage with fast changing, it should avoid long distance wiring side by side of motor cable and other cables.
- 3) When control cable must cross drive cable, it should ensure the angle of two cables with 90 degree. Do not cross other cables with inverter.
- 4) The drive input, output and weak signal cable (e.g. control cable) of inverter should not wire parallel. With condition available, it is better to wire vertically.
- 5) Please keep good connection of cable wire casings and fine grounding. Aluminum wire casing could improve equipotential voltage.
- 6) Filter, inverter, and motor should be in good connection with system (mechanical equipments) with painting protection of installed parts and sufficient contact with conductive metal.

Wiring distance as below fig.

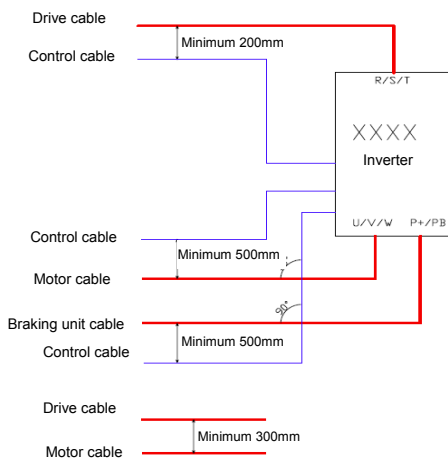

- In somewhere CE conformed or EMC radiation must be reduced, cable entry should keep high frequency ground in 360 degree to restrain electro magnetic interference. In addition, cable shield layer should connect with PE wire to meet safety regulation.
- In floating or high ground (>30Ohms) power system, EMI filter cannot be installed.

## 12.7 LEAKAGE CURRENT RESPONSE REQUIREMENTS

- 1) The output of inverter is high-speed pulse voltage, therefore it will generate high frequency leakage current. To prevent electro shock and fire evoked by leakage current, please install leakage circuit breaker for inverter.
- 2) The leakage current produced by inverter is relatively large, instant leakage current of large power inverter may be tens of milliamperes, so inductive current of leakage circuit breaker should be larger than 100mA.
- 3) High frequency pulse interference might cause leakage circuit breaker malfunction under interference, please choose leakage circuit breaker with a high frequency filter.
- 4) If to install several inverters, each inverter should have a leakage circuit breaker.
- 5) Factors that affect leakage current, as follows:



- ◆ Inverter capacity
  - ◆ Carrier frequency
  - ◆ Type and length of motor cable
  - ◆ EMI filter
- 6) When leakage current of inverter cause leakage circuit breaker work:
- ◆ Improve sensitivity of the current value of leakage circuit breaker
  - ◆ Replace a new leakage circuit breaker with high frequency inhibition function
  - ◆ Reduce carrier frequency
  - ◆ Shorten length of output cable
  - ◆ Install a leakage suppression equipment

## 12.8 COMMON EMC INTERFERENCE PROBLEM AND SOLUTION

Frequency inverter is strong anti-interference equipment, when there is problem in wiring and ground connection, still maybe will comes out interference. When it happens, we have below solutions:

Interference Type	Solution
Leakage protection switch trip	<ul style="list-style-type: none"> <li>◆ Motor case connect the PE of frequency inverter;</li> <li>◆ Frequency inverter PE connect the power system PE;</li> <li>◆ Add Safety capacitance box on input power wire;</li> <li>◆ Add magnetic loops on input power wire;</li> </ul>
Running Drive leads Interference	<ul style="list-style-type: none"> <li>◆ Motor case connect the PE of frequency inverter; ;</li> <li>◆ Frequency inverter PE connect the power system PE;</li> <li>◆ Add Safety capacitance box and magnetic loops on input power wire;</li> <li>◆ Add Capacitor or magnetic loops on the interferenced port ;</li> <li>◆ Share the ground wire between the equipments;</li> </ul>
Communication Interference	<ul style="list-style-type: none"> <li>◆ Motor case connect the PE of frequency inverter; ;</li> <li>◆ Frequency inverter PE connect the power system PE;</li> <li>◆ Add Safety capacitance box and magnetic loops on input power wire;</li> <li>◆ Add matched resistor On communication wire and load end;</li> <li>◆ Add communication common GND on communication wire;</li> <li>◆ communication wire use shielded wire, shields connect public Communication;</li> </ul>
I/O Interference	<ul style="list-style-type: none"> <li>◆ Add capacitor filter on low-speed DI, maximum 0.1uF;</li> <li>◆ Add capacitor filter on AI, maximum 0.22uF;</li> <li>◆ Analog signal use shielded wire, shields connect PE of frequency inverter.</li> </ul>

Remark: If you have any other EMC interference questions, please contact the manufacturer.

## 13. ACCESSORIES

### 13.1 BRAKE ASSEMBLY

Operating principle: When the inverter drags the motor for acceleration and reversing, the voltage of the DC bus inside the inverter may increase due to the motor's energy feedback. In order to prevent the inverter from stopping as a result of over voltage protection, the brake unit will automatically connect to the energy dissipation circuit before the voltage of the DC bus reaches the protection point. Hence the energy can be released in the way of heat energy via the braking resistance, so as to prevent voltage rising continuously.

#### 13.1.1 MODEL OF BRAKE UNIT

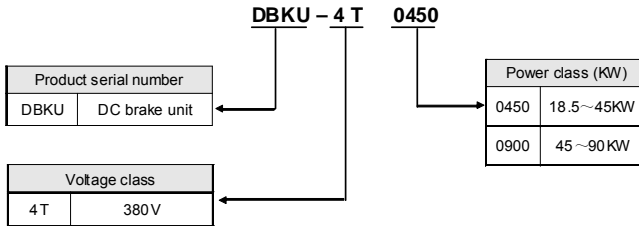

Figure 13-1 Sketch of model description

#### 13.1.2 GUIDE OF BRAKE RESISTANCE SELECTION

Users are able to select resistance value and power according to actual needs, (but selected resistance value can't be lower than recommended value in below table, while selected resistance power can be bigger). Selection of brake resistance depends on motor generation power in system, and in concern with system inertia, deceleration time, energy of potential energy load etc. The bigger system inertia, shorter deceleration time and more frequent braking time, then to choose bigger power of brake resistance and lower resistance value.

##### 1 Resistance value selection

While braking, almost all motor regeneration energy consumes at braking resistance. The formula:

$$U \cdot U / R = P_b$$

U---- braking voltage under stable system braking state (it varies from different systems, it takes 700V for common AC 380V system)

P<sub>b</sub>----power of braking

##### 2 Power of brake resistance selection

The power of brake resistance and power of braking keep consistent in theory, but should take 70% derating into account. The formula:

$$0.7 \cdot P_r = P_b \cdot D$$

Pr---- power of brake resistance

D---- braking frequency (time proportion of regeneration process accounts for the whole process), generally it is 10%. Please refer to table below:

Type	Lift	Winding & unwinding	Centrifuge	Accidental braking load
Proportion	20%~30%	20%~30%	50%~60%	5%

### Brake resistance selection table

Model	Adaptive motor (KW)	Power of brake resistance (KW)	Brake resistance value (Ω)	Brake torque (100%)	Brake unit
V560-4T0007	1.1	0.3	≥400	100	Standard
V560-4T0011	1.1	0.3	≥400	100	Standard
V560-4T0015	1.5	0.5	≥300	100	Standard
V560-4T0022	2.2	0.65	≥200	100	Standard
V560-4T0030	3.0	0.75	≥150	100	Standard
V560-4T0040	4.0	1.0	≥125	100	Standard
V560-4T0055	5.5	1.5	≥85	100	Standard
V560-4T0075	7.5	2.0	≥65	100	Standard
V560-4T0090	9.0	2.5	≥60	100	Standard
V560-4T0110	11	2.5	≥50	100	Standard
V560-4T0150	15	3.6	≥35	100	Standard
V560-4T0185	18.5	4.5	≥30	100	Standard
V560-4T0220	22	5.5	≥25	100	Standard

If need braking function of the model upon V560-4T0220, please refer to the braking unit manual.

### 13.1.3 APPEARANCE OF BRAKE UNIT

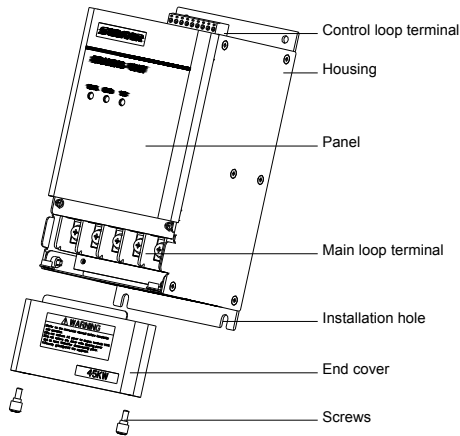

Figure 13-2 Appearance sketch

### 13.1.4 INSTALLATION SIZE OF BRAKE UNIT

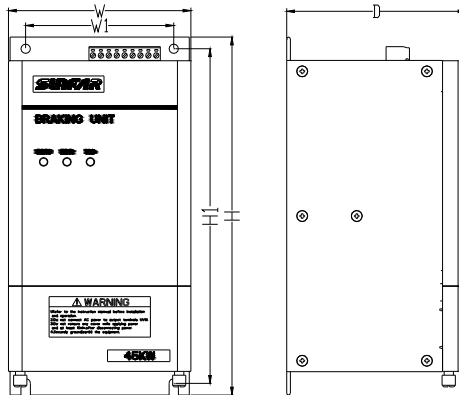

Figure 13-3 Installation size diagram

The installation size of brake unit is shown in the following table:

Model of the brake unit	W1 (mm)	W (mm)	H1 (mm)	H (mm)	D (mm)	Screw specification
DBKU-4T0450(4T0900)	95	117	215	230	115	M5

### 13.1.5 SINGLE BRAKE UNIT AND INVERTER REFERENCE WIRING SKETCH

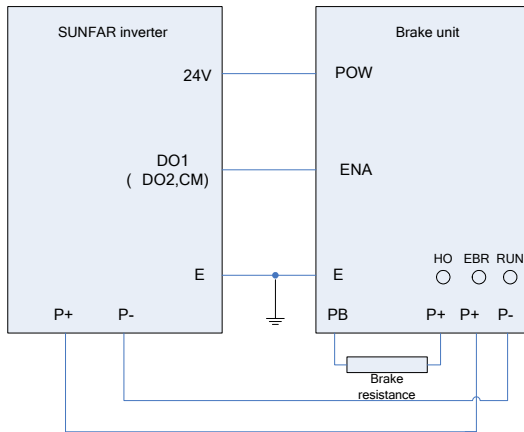

Figure 13-4 Wiring sketch

When the braking enabling (forbidding) function of the brake unit is applied, before the inverter starts running, it is a must to set the function of the inverter's deceleration effective control terminal (the control terminal corresponding to SUNFAR inverter is DO1 or DO2) connected to ENA to be effective during the deceleration process. If this function is not needed, please connect ENA to 24V common port CM.

### 13.1.6 WIRING PRECAUTIONS

1. When connecting wires between the inverter and brake unit, reverse connection of P+ and P- will burn the brake unit and damage the inverter. Be sure to check carefully before powering on the inverter.
2. For installation and wiring of the main loop, be sure to disconnect the inverter or power it off and wait for 5-10 minutes until the power indicator of the inverter or the brake unit goes off. The wiring of the control loop cannot be done with the mains power is connected principally.
3. Be sure to keep the control loop wires away from the connecting wires of main power circuit, in order to prevent improper action caused by interfering noise. If the control loop wires have to pass through the main loop connecting wires, be sure to make it pass through vertically. If the distance between the connecting wires is excessive, be sure to use twisted pair or shielded wires.

For more instructions of the brake unit please refer to the operating manual of the brake unit by visiting our website to download: <http://www.sunfars.com>.

### 13.2 I/O EXPANSION CARD (STANDARD TYPE: IOV-D104, PN: 050M008003000)

Aside from providing standard I/O port on the mainboard, V560 series inverter can also additionally provide more input and output terminals according to users' requirements. The standard I/O expansion card has following functions:

- One group of RS485 channel;
- ±10V power supply (load capacity≤10mA);
- Three-circuit input terminal DI7~DI9, among which DI9 can receive pulse input within100.00KHz;
- One-circuit digital output DO3, with the capability of outputting high-speed pulse (F0);
- One-circuit analog input AI3 (-10V~10V).
- One-circuit relay programmable output (2A normally open\normally closed contact).

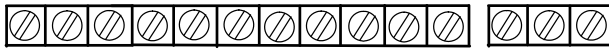

RS+ RS- GND -10V +10V AI3 CM DO3 DI9 DI8 DI7 TA1 TB1 TC1

Figure 13-5 I/O expansion card terminal diagram

Table 13-1 Introduction of I/O expansion card terminal

Terminal type	Terminal name	Function
485 communication	RS+,RS-	Physical port for RS485 communication; See FA parameter for details
Output power supply	+10V,-10V	Provide ±10V/10mA power supply
Analog input	AI3	Analog 0~10V input, input impedance≥100M Ohm; See F4 parameter for details.
Digital input	DI7,DI8	Effective when the Terminal and CM port is engaged. DI7 and DI8 input frequency≤1KHz.
	DI9	Programmable pulse input; Effective when the Terminal and CM port is engaged. DI9 input frequency≤100 KHz; See F3 parameter for details.
Digital output	DO3	Programmable OC output; output frequency≤100K Hz; See F3 parameter for details.
Programmable output	TA1	TA1-TB1 normally closed contacts; TA1-TC1 normally open contacts; See F3 parameter for the contact capacity: AC 250V/1A
	TB1	
	TC1	
Common port	GND	Common port for ±10V,AI3
Common port	CM	Common port for DO3,DI7,DI8, and DI9

### 13.3 PG EXPANSION CARD (STANDARD TYPE:PGV-C000, PN: 050M009012002)

V560 series inverter is designed with the closed-loop vector control mode. When users select this mode, PG card must be adopted. PG card can receive single-ended collector open-circuit output, push-pull output and differential output encoder signals.

Index of standard PG expansion card:

- ◆ Providing one group of +12V power supply (load capacity $\leq$ 200mA);
- ◆ Providing three-phase differential input standard port of incremental encoder;
- ◆ Differential voltages $\leq$ +12V;
- ◆ Maximum resolution 8192 C/T;
- ◆ Response frequency $\leq$ 200KHz.

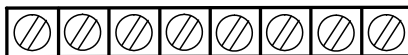

+12V GD A+ A- B+ B- Z+ Z-

Figure 13-6 Terminals of PG expansion card

Table 13-2 Introduction of PG expansion card terminal

Terminal name	Function
+12V	Externally providing +12V/200mA current
GD	Power supply reference point
A+	Encoder A-phase differential input (+12V $\pm$ 20%), max frequency $\leq$ 200 KHz
A-	
B+	Encoder B-phase differential input (+12V $\pm$ 20%), max frequency $\leq$ 200 KHz
B-	
Z+	Encoder Z-phase differential input (+12V $\pm$ 20%), max frequency $\leq$ 200 KHz
Z-	

## 13.4 INTRODUCTION OF LCD OPERATING PANEL

### 13.4.1 OUTSIDE VIEW OF LCD OPERATING PANEL

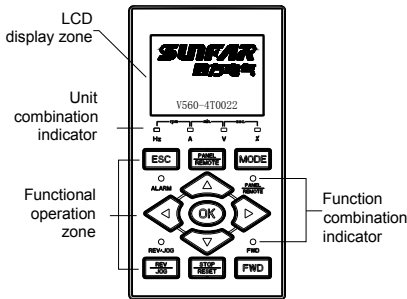

Figure 13-6-A Standard type of bilingual LCD  
(Model DPNL360CA /PN: 050M007360001)

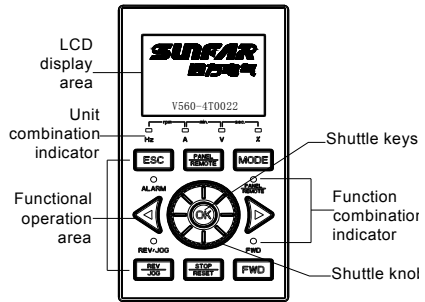

Figure 13-6-B Shuttle type of bilingual LCD  
(Model DPNL360CA /PN: 050M007360002)

### 13.4.2 LED OPERATION PANEL

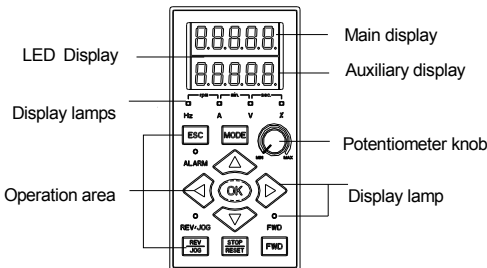

Figure 13-6-C double-line LED potentiometer panel  
(Model DPNL350EN /PN: 050M007033601)

### 13.4.3 FUNCTION OF KEYS

Refer to Chapter 5 for the function and operation of keys on LCD panel.

**Please refer to the product catalogue if you want to know more about optional accessories.**