



Simphoenix

SERVO DRIVE | VFD | PMSM | PLC | HMI



CD200 Series Digital Pulse Servo Drive

Shenzhen Simphoenix Electric Technology Co., Ltd

Address: Building A, Huichao Industrial Park, 2nd Rd of Gushu, Xixiang,
Baoan District, Shenzhen, Guangdong, China

Tel: 86-755-26607756, 26910801

Fax: 86-755-26912599, 26919882

E-mail: business01@sunfardrive.com / business02@sunfardrive.com

Web: www.simphoenix.com

Huizhou Simphoenix Electric Co., Ltd

Address: No. 23 Songbailing Avenue, Startup Area, China-Korea Huizhou Industrial Park,
Zhongkai High-Tech Zone, Huizhou, Guangdong Province, China

Tel: 86-755-2600100

V1.1-2026.05





Enterprise Mission

Creat value for customers



Enterprise Spirit

Innovation and enterprising



Core Value

Integrity, win-win,
pragmatic, dedication



Business Philosophy

People oriented and
common progress

5 Regions

18 Overseas sales network

35+ Offices

Established in 2004, Shenzhen Simphoenix Electric Technology Co., Ltd. is committed to becoming an outstanding provider of automation products and solutions. The company specializes in the development, production, sales and service of industrial automation products, the main products are servo drive, inverter, permanent magnet synchronous motor, PLC, HMI and so on. In addition, Huizhou Simphoenix Electric Co., Ltd., a wholly-owned subsidiary of Simphoenix Electric, focuses on the field of automation and works together with its parent company to provide customers with first-class products and solutions.

After more than 20 years of development, Simphoenix has become a well-known brand with complete product structure and strong r&d strength among domestic industrial automation brands.



CD200 Series Digital Pulse Servo Drive



CD200 series Digital Pulse Servo Drive is a general-purpose high-performance AC servo driver developed by Simphoenix. It supports Modbus and CANopen communication protocols, by utilizing the corresponding communication interface and coordinating with the host controller, multi-axis servo networking operation can be achieved. The CD200 supports adaptive stiffness level setting, 1 second inertia auto-tuning, online load measurement, and vibration suppression for easy use. Combined with CM10 series high response servo motors, it runs reliably and smoothly. The drive aims to achieve quick and accurate position control, speed control, and torque control through high performance solutions for automation equipment in such industries as packaging, food production, CNC cutting, textiles, machine tools, woodworking carving, etc.

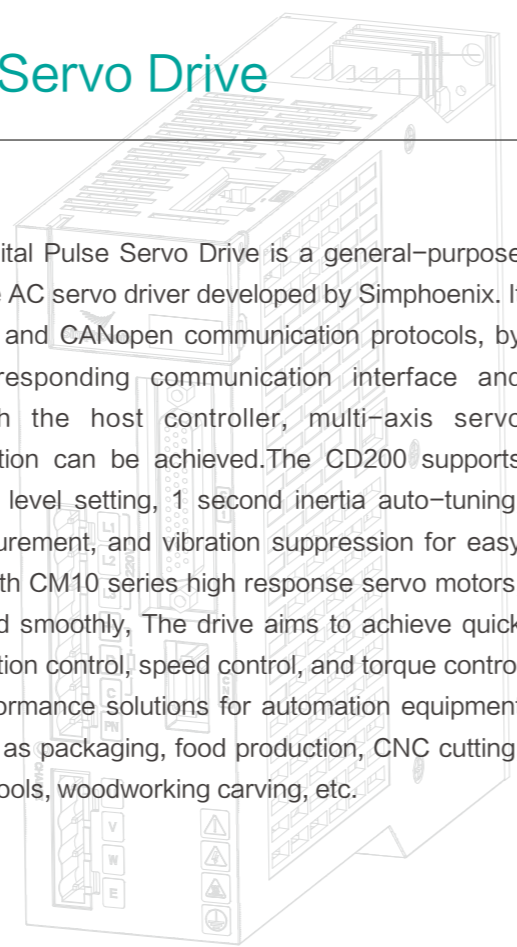

Industry Application



Breaking through limits, intelligent high-frequency control

- ◆ Innovate digital pulse bus technology, with up to 5MHz high-frequency pulse input and intelligent anti-interference to ensure zero pulse loss, redefining industrial grade pulse transmission standards!

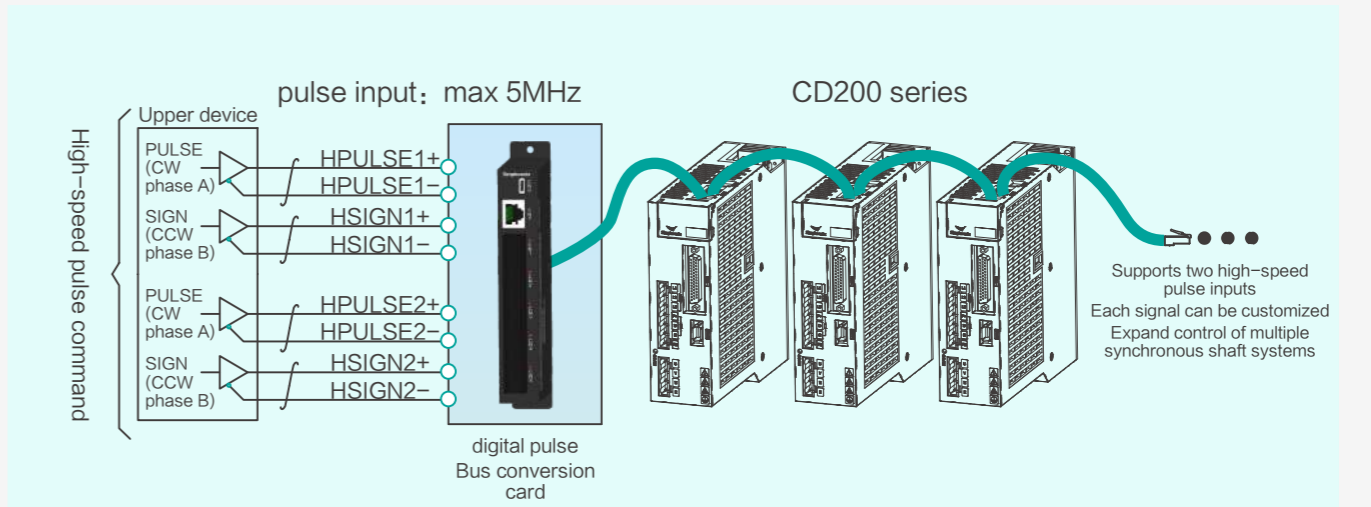

- ◆ Equipped with model following control algorithm, it achieves high dynamic trajectory tracking and minimal position error, greatly shortening positioning time while upgrading overall processing quality.

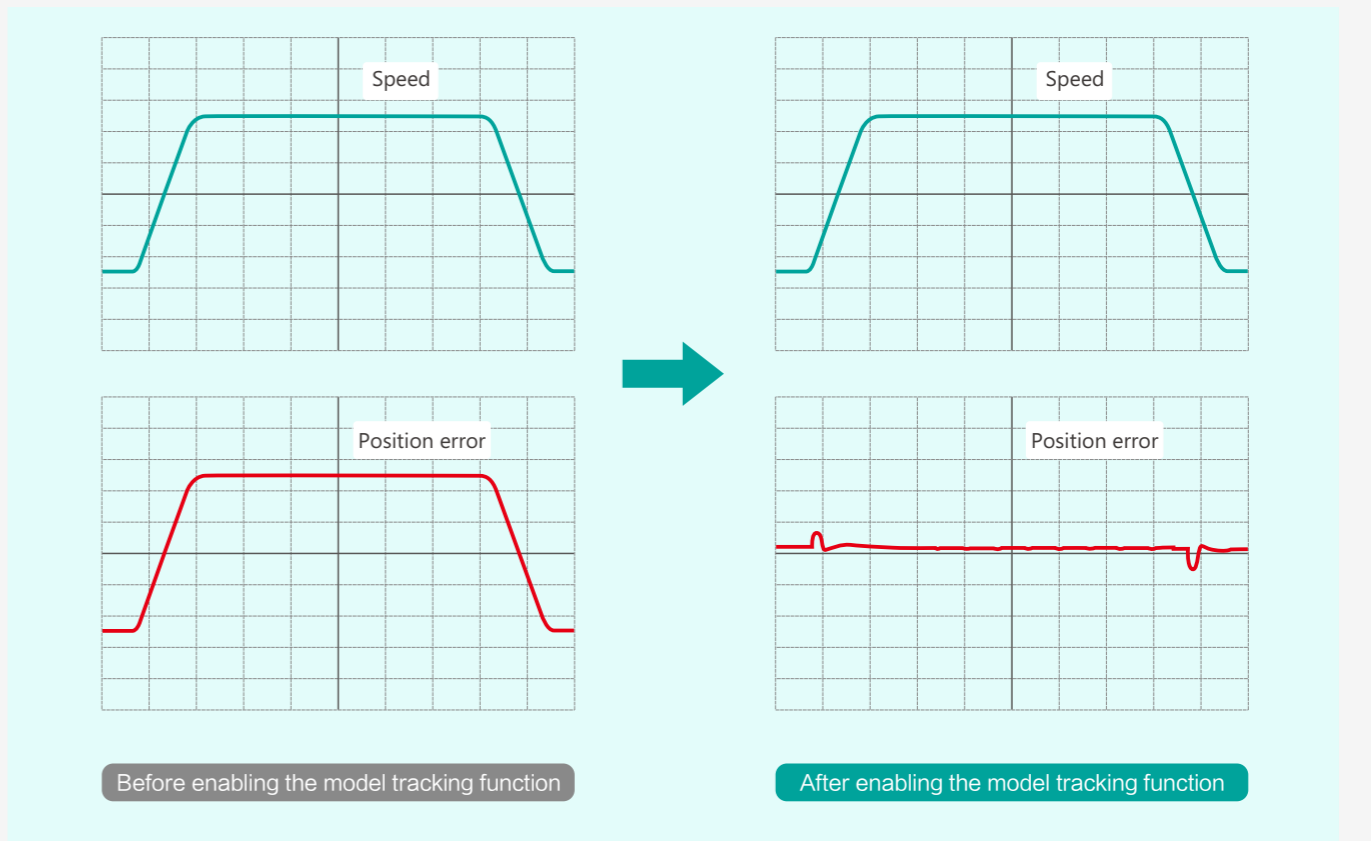

- ◆ The position control frequency can reach up to 16kHz, achieving higher dynamic response.

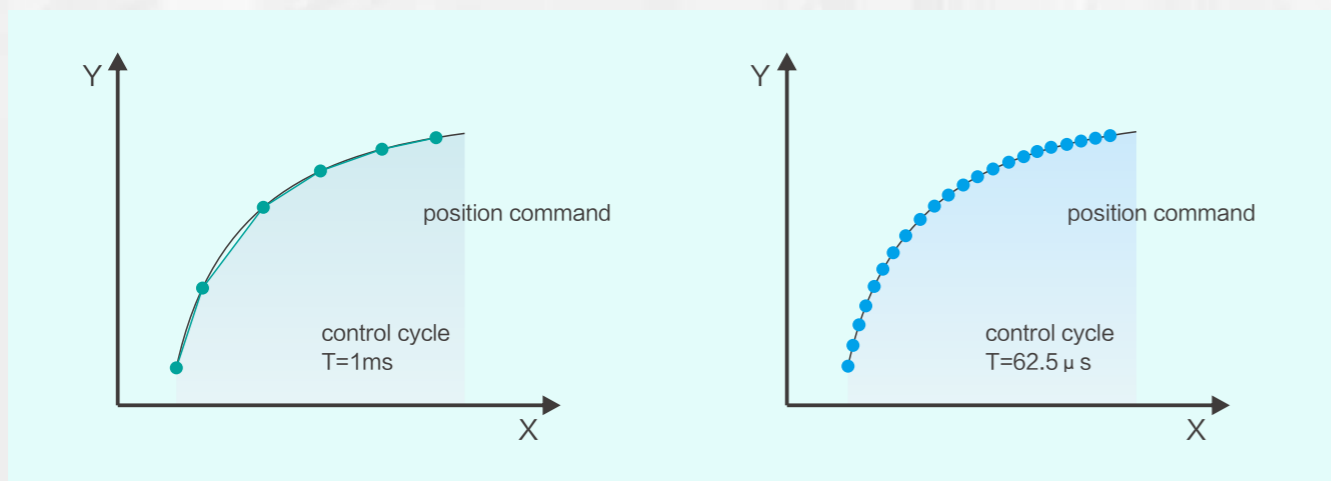

- ◆ Advanced operation compensation, resonance and end vibration suppression algorithms effectively shorten the setting time and ensure smooth, high-speed and high-precision positioning of equipment.

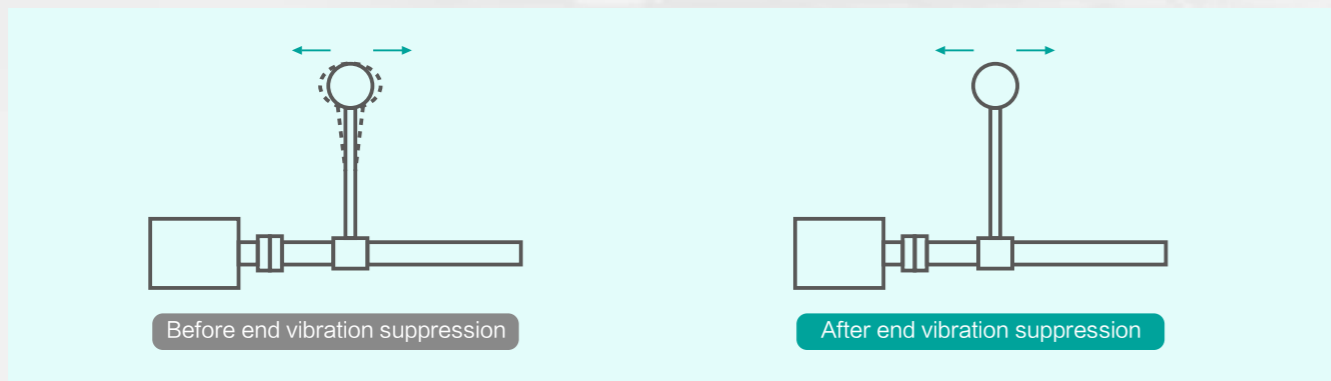

Extended functionality

- ◆ The vibration suppression function achieves high response without reducing bandwidth, and effectively suppresses vibration caused by high response.

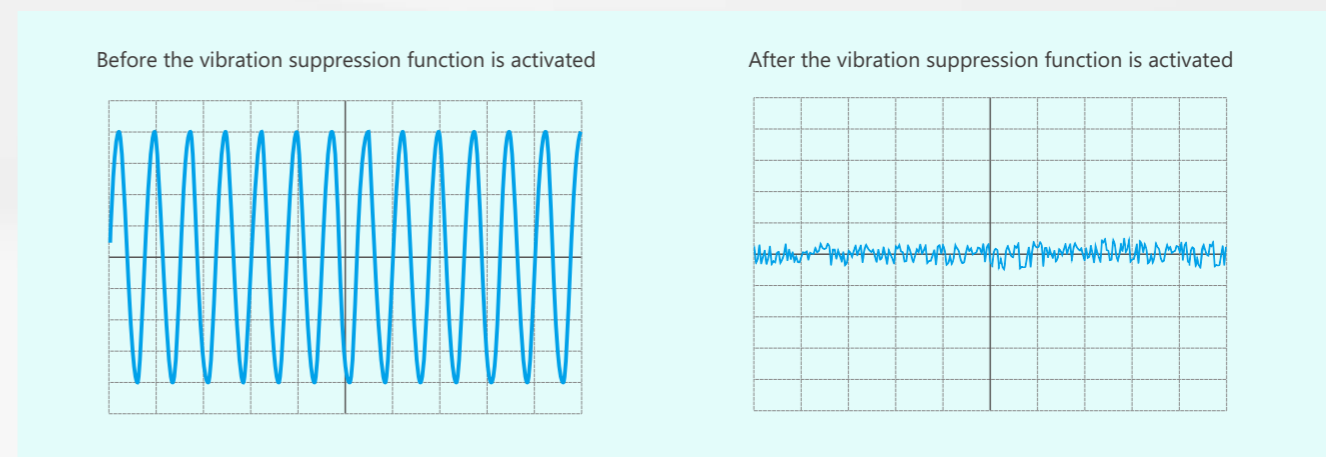

- ◆ Leading mechanical frequency characteristic scanning and control loop simulation function, assisting in the analysis of equipment mechanical performance.

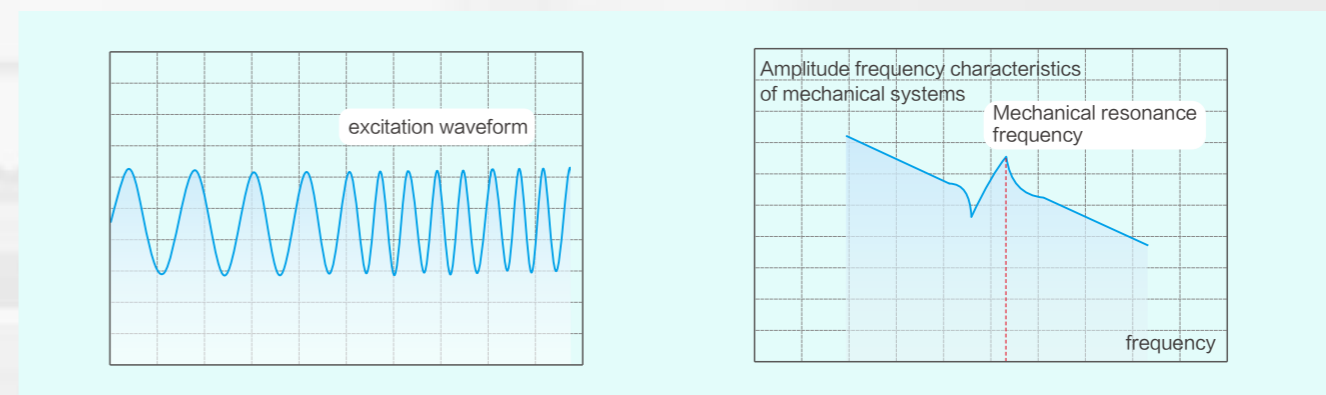

- ◆ 32 built-in programmable motion profiles enable flexible constant-speed and positioning control, reducing dependency on external motion controllers in specific applications.

◆ Multi-inertia identification technology accommodates diverse application needs for rapid positioning and smooth operation. With one-click adjustment, it effortlessly achieves inertia identification and parameter auto-tuning, significantly reducing commissioning complexity and shortening commissioning period.



◆ Compatible with multiple resolution encoders, supporting up to 26 bit high-resolution encoders; Automatically read internal data of the motor and intelligently match the motor.

17-26 bit encoder optional

Maximum system overload capacity **300%**

2

Maximum speed **6000rpm**

Rapid start-stop response
Driving efficiency gains

Effortless to use and engineered to protect

- Compact size, optimized structure
- Optimized design of independent heat dissipation channels
- Low temperature power boosting devices, Ensure a long service life
- Open up a new path for pulse digital bus control
- Support multiple fault protections
- Adequate component reliability testing to ensure the overall quality of the driver

Technical Specifications

Specification

Main power supply	Single-phase 220 ~ 240VAC, -15% ~ +10% (50/60Hz) Three-phase 380 ~ 415VAC, -15% ~ +10% (50/60Hz)	
Control mode	FOC+SVPWM	
Encoder	Serial communication encoder: 17 bit to 26 bit optional	
Protection	Overcurrent, abnormal voltage, overload, input/output phase loss, motor stalling, overspeed, abnormal pulse command, brake resistor overload, driver overheating, encoder abnormality, etc	
Conditions of use	temperature	Operating temperature: 0°C~+45°C (ambient temperature 45°C~50°C, please reduce the rated use. For every 1°C increase, the current will decrease by 2%) Storage temperature: -20°C~+60°C
	humidity	Relative humidity below 90% RH (non condensing)
	vibrate	0.5g (4.9m/s ²)
	protection	IP20
	altitude	Below 1000m (>1000m, Please reduce the usage amount)
other	1: No static interference, strong electric field, strong magnetic field, radiation, etc 2: No corrosive gases, flammable gases, water, oil, or drug splashes 3: In an environment with less dust, dirt, salt, and metal powder	
Digital input	8DI (DC24V optocoupler isolation, Support NPN and PNP)	
Digital output	4DO (Optocoupler isolation, open collector output, 50mA load capacity with 5-28V operating voltage range)	
Load variation rate	When 0~100% load: ≤ 0.5% (at rated speed)	
Voltage regulation	Rated voltage ± 10%: 0.5% (at rated speed)	
Speed control range	1: 5000 (The lower limit of the speed control range is the condition of not stopping at rated torque load)	
Torque control accuracy	± 2%	
Multi segment speed command	Using DI signal combination to achieve speed selection for segments 0-31	
Pulse command	input pulse mode	"Pulse+direction", "phase A, B orthogonal pulse" and "CW/CCW pulse", digital pulse bus
	input form	Differential input, open collector
	input pulse frequency	Differential input: orthogonal 500 Kpps, pulse width cannot be less than 1 μ s Open collector: the maximum pulse frequency for a single channel is 200 Kpps, and the pulse width cannot be less than 2.5 μ s digital pulse bus: maximum 5 MHz
Position output	output form	A-phase/B-phase: differential output Z-phase: differential output or open collector output
	frequency division ratio	Any frequency division
Multi segment position command	Using DI signal combination to achieve position selection for segments 0-31	
Closed loop	Supports external ABZ type and communication encoder access, only supported by CD200C	
Communication Function	RS485	Link layer protocol: RS485 Application layer protocol: Modbus-RTU, proprietary protocol (for digital pulse usage) Baud rates: 4800bps, 9600bps, 19200bps, 38400bps, 57600bps, 115200bps Duplex mode: Half duplex Number of communication axes, for multiple stations: up to 32 stations
	CANopen	CD200C supports
	Type-C	Used for communication with PC (X Servo Configurator)
	Vibration suppression	Two vibration suppression notch filters: adjustable vibration suppression frequency and intensity Two notch filters: can set notch frequency, width, and depth
Overtravel prevention	Positive limit, negative limit, software limit	
Virtual braking	In some cases, electric motors can be used for virtual regenerative braking, replacing braking resistors	
LED display	Main power supply CHARGE, 6-digit LED display	
Other	Gain adjustment, inertia identification, mechanical frequency analysis, alarm recording, JOG operation, etc	

Control Signal

Speed/torque Control Mode

Position Control Mode

Communication Function

Internal Function

Naming Convention for Servo Drive

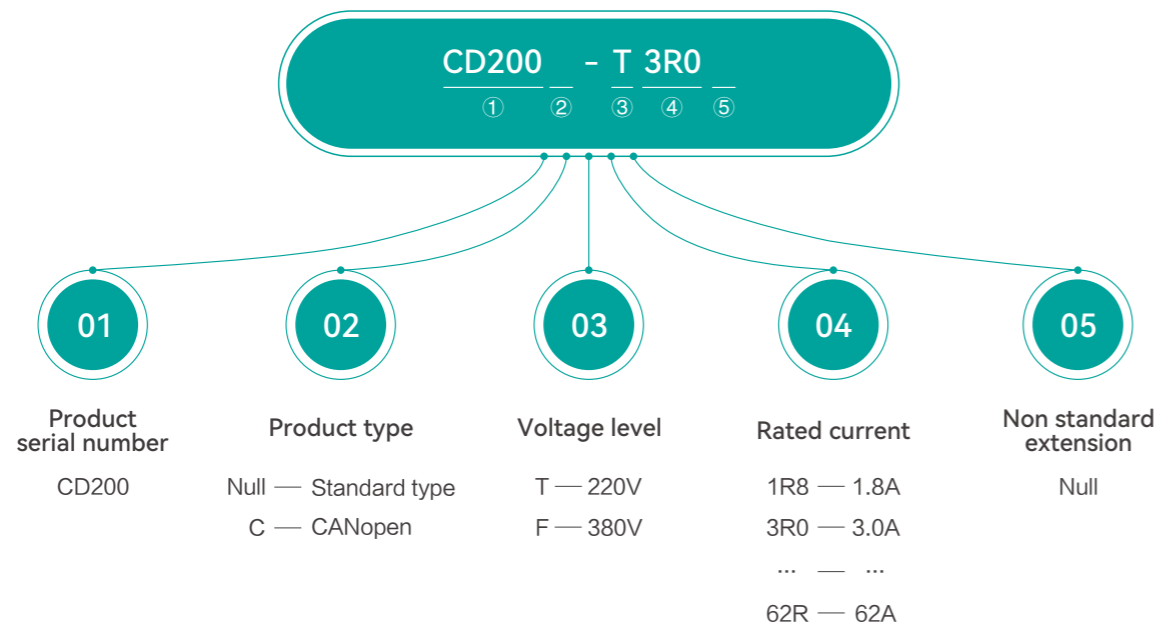

Model List

Voltage Class	Drive Model	Rated Current (A)	Maximum Adaptive Motor Power (kW)
Single-phase AC220V	CD200-T1R8	1.8	0.20
	CD200-T3R0	3.0	0.75
	CD200-T4R0	4.5	1.0
Single-phase/ three-phase AC220V	CD200-T4R5	4.5	1.0
	CD200-T5R5	5.5	1.3
	CD200-T7R5	7.5	2.0
	CD200-T10R	10.0	2.1
	CD200-T13R	13.0	2.3
Three-phase AC380V	CD200-F4R0	4.0	1.5
	CD200-F6R5	6.5	2.3
	CD200-F8R5	8.5	3.0
	CD200-F12R	12.0	4.5
	CD200-F17R	17.0	4.4 (5-pole pair)
	CD200-F22R	22.0	5.5
	CD200-F27R	27.0	7.5
	CD200-F38R	38.0	15
	CD200-F52R	52.0	22
	CD200-F62R	62.0	30

Installation Dimensions

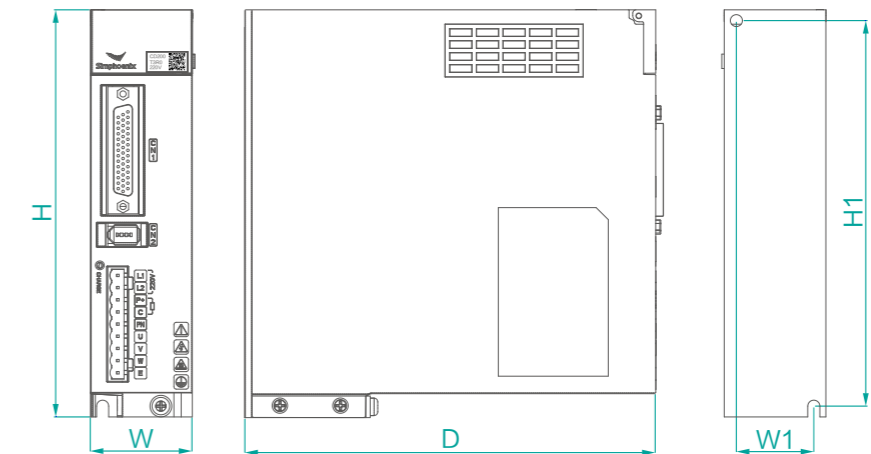

Drive Model	W1 (mm)	W (mm)	H1 (mm)	H (mm)	D (mm)	Screw diameter	Weight (KG)
T1R8/T3R0/T4R0	32	42	161	170	170	M4	1
T4R5/T5R5/T7R5	40	50	161	170	170	M4	1.3
T10R/T13R	64	80	186	195	182	M4	2.1
F4R0/F6R5/F8R5/F12R	64	80	186	195	182	M4	2.1
F17R/F22R/F27R	70	95	263	276	227	M4	4.9
F38R/F52R/F62R	100	150	410	426	250	M6	12.7

Installation spacing

To ensure adequate cooling performance, please observe the following requirements when installing the servo drive:
 Maintain sufficient clearance on all four sides; do not block the air intake and exhaust vents, and installation in an upside-down orientation is prohibited. For side-by-side installation of multiple units, follow the spacing shown in the diagram.

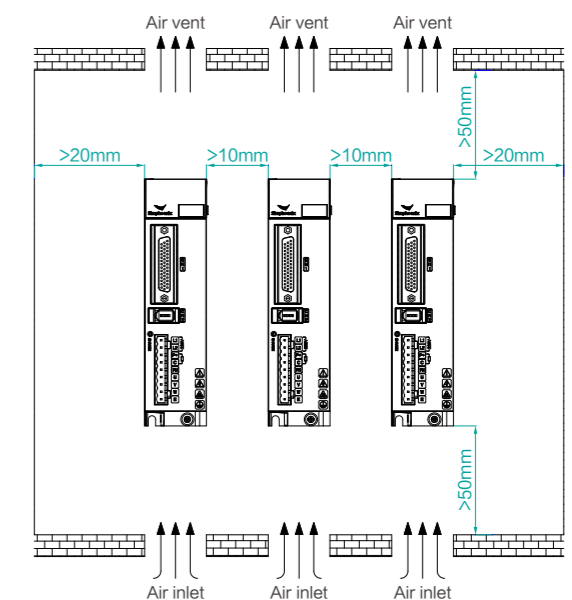

CD200 Compatible with CM10 Servo Motor and Cable Selection Table

Motor Model	Motor Code	Adapted Driver	Power (kW)	Rated Current (A)	Rated Torque (Nm)	Rated Speed (rpm)	Flange	Encoder Cable	Power Cable	Brake Cable
CM10-B40TR3230B4□L4-1S	2011	T1R8□	0.1	1	0.32	3000	40	SP-WD□□□05PAHO-0□	SP-WM□□□05DAHP-1□	Brake-power line integration
CM10-B60TR6430C3□L2-1S	2010	T1R8□	0.2	1.6	0.64	3000	60	SP-WD□□□07PAHO-0□	SP-WM□□□05DAHN-1□	Brake-power line integration
CM10-B60TR6430C3□L2	2010	T1R8□	0.2	1.6	0.64	3000	60	SP-WD□□□07PAID-0□	SP-WM□□□05DAIB-0□	SP-WB□□□02DAIA-0□
CM10-B60T01330C3□L2-2S	2020	T3R0□	0.4	2.6	1.27	3000	60	SP-WD□□□07PAHO-0□	SP-WM□□□05DAHN-1□	Brake-power line integration
CM10-B60T01330C3□L2	2020	T3R0□	0.4	2.6	1.27	3000	60	SP-WD□□□07PAID-0□	SP-WM□□□05DAIB-0□	SP-WB□□□02DAIA-0□
CM10-B80T02430C3□L2-3S	2021	T3R0□	0.75	3	2.40	3000	80	SP-WD□□□07PAHO-0□	SP-WM□□□05DAHN-1□	Brake-power line integration
CM10-B80T02430C3□L2-3A	2021	T3R0□	0.75	3	2.40	3000	80	SP-WD□□□07PAID-0□	SP-WM□□□05DAIB-0□	SP-WB□□□02DAIA-0□
CM10-B80T03230C3□L2-4S	2042	T4R5□	1	4.5	3.20	3000	80	SP-WD□□□07PAHO-0□	SP-WM□□□07DCHN-1□	Brake-power line integration
CM10-B80T03230C3□L2-4A	2042	T4R5□	1	4.5	3.20	3000	80	SP-WD□□□07PAID-0□	SP-WM□□□07DCIB-0□	SP-WB□□□02DABH-0□
CM10-B130T05430C3□M2	2050	T5R5□	1.7	5.5	5.40	3000	130	SP-WD□□□07PAHC-0□	SP-WM□□□07DCHA-1□	SP-WB□□□02DABH-0□
CM10-A130T07725C3□M3	1050	T7R5□	2	7.5	7.70	2500	130	SP-WD□□□07PAHC-0□	SP-WM□□□07DCHA-1□	SP-WB□□□02DABH-0□
CM10-A130T10015C3□M3	1054	T7R5□	1.5	6	10.00	1500	130	SP-WD□□□07PAHC-0□	SP-WM□□□07DCHA-1□	SP-WB□□□02DABH-0□
CM10-B130T08415C3□M2	2060	T10R□	1.3	9	8.40	1500	130	SP-WD□□□07PAHC-0□	SP-WM□□□15DBHA-1□	SP-WB□□□02DABH-0□
CM10-B130T11515C3□M2	2070	T13R□	1.8	12	11.50	1500	130	SP-WD□□□07PAHC-0□	SP-WM□□□15DBHA-1□	SP-WB□□□02DABH-0□
CM10-B130F05415C3□M2	2410	F4R0□	0.85	3.5	5.40	1500	130	SP-WD□□□07PAHC-0□	SP-WM□□□15DBHA-1□	SP-WB□□□02DABH-0□
CM10-A130F10015C3□M3	1415	F4R0□	1.5	4	10.00	1500	130	SP-WD□□□07PAHC-0□	SP-WM□□□15DBHA-1□	SP-WB□□□02DABH-0□
CM10-B130F08415C3□M2	2411	F6R5□	1.3	5.1	8.40	1500	130	SP-WD□□□07PAHC-0□	SP-WM□□□15DBHA-1□	SP-WB□□□02DABH-0□
CM10-A130F15015C3□M3	1410	F6R5□	2.3	5	15.00	1500	130	SP-WD□□□07PAHC-0□	SP-WM□□□15DBHA-1□	SP-WB□□□02DABH-0□
CM10-B130F09630C3□M2	2421	F8R5□	3	8.4	9.6	3000	130	SP-WD□□□07PAHC-0□	SP-WM□□□15DBHA-1□	SP-WB□□□02DABH-0□
CM10-B130F11515C3□M2	2420	F8R5□	1.8	7	11.50	1500	130	SP-WD□□□07PAHC-0□	SP-WM□□□15DBHA-1□	SP-WB□□□02DABH-0□
CM10-A180F19015R3□L3	1520	F8R5□	3	7.5	19.00	1500	180	SP-WD□□□07PAHC-0□	SP-WM□□□15DBHB-1□	SP-WB□□□02DABI-0□
CM10-A180F27010R3□L3	1524	F8R5□	2.9	7.5	27.00	1000	180	SP-WD□□□07PAHC-0□	SP-WM□□□15DBHB-1□	SP-WB□□□02DABI-0□
CM10-B180F18615R3□L2	2530	F12R□	2.9	11	18.60	1500	180	SP-WD□□□07PAHC-0□	SP-WM□□□15DBHB-1□	SP-WB□□□02DABI-0□
CM10-A180F21520R3□L3	1530	F12R□	4.5	9.5	21.50	2000	180	SP-WD□□□07PAHC-0□	SP-WM□□□15DBHB-1□	SP-WB□□□02DABI-0□
CM10-A180F27015R3□L3	1535	F12R□	4.3	10	27.00	1500	180	SP-WD□□□07PAHC-0□	SP-WM□□□15DBHB-1□	SP-WB□□□02DABI-0□
CM10-B180F28415R3□L2	2540	F17R□	4.5	17	28.40	1500	180	SP-WD□□□07PAHC-0□	SP-WM□□□40EAHB-1□	SP-WB□□□02DABI-0□
CM10-B180F35015R3□L2	2550	F22R□	5.5	21	35.00	1500	180	SP-WD□□□07PAHC-0□	SP-WM□□□40EAHB-1□	SP-WB□□□02DABI-0□
CM10-B180F48015R2□L2	2560	F27R□	7.5	26	48.00	1500	180	SP-WD□□□07PAHC-0□	SP-WM□□□40EAHB-1□	SP-WB□□□02DABI-0□
CM10-A200F70015R2□L2B	1561	F27R□	11	21	70.00	1500	200	SP-WD□□□07PAHC-0□	SP-WM□□□40EAHB-1□	SP-WB□□□02DABI-0□

The □ suffix of the motor: G=Without brake;
H=With brake
Encoder type(5th to last specification):
C=17 bit multi turn magnetic encoder,
R=23 bit multi turn optical encoder
Voltage level: T=220V, F=380V

Driver suffix □
□=None, base model

Wiring selection for multi turn encoders
05=Single coil encoder wiring
07=Multi turn encoder wiring

Three □ in the middle of the wire harness specification
□□□=030, 3 meters
□□□=050, 5 meters
□□□=100, 10 meters

The last □ of the wiring harness suffix
□=1, Ordinary line
□=2, high flexibility line

Naming Rules for Servo Motor

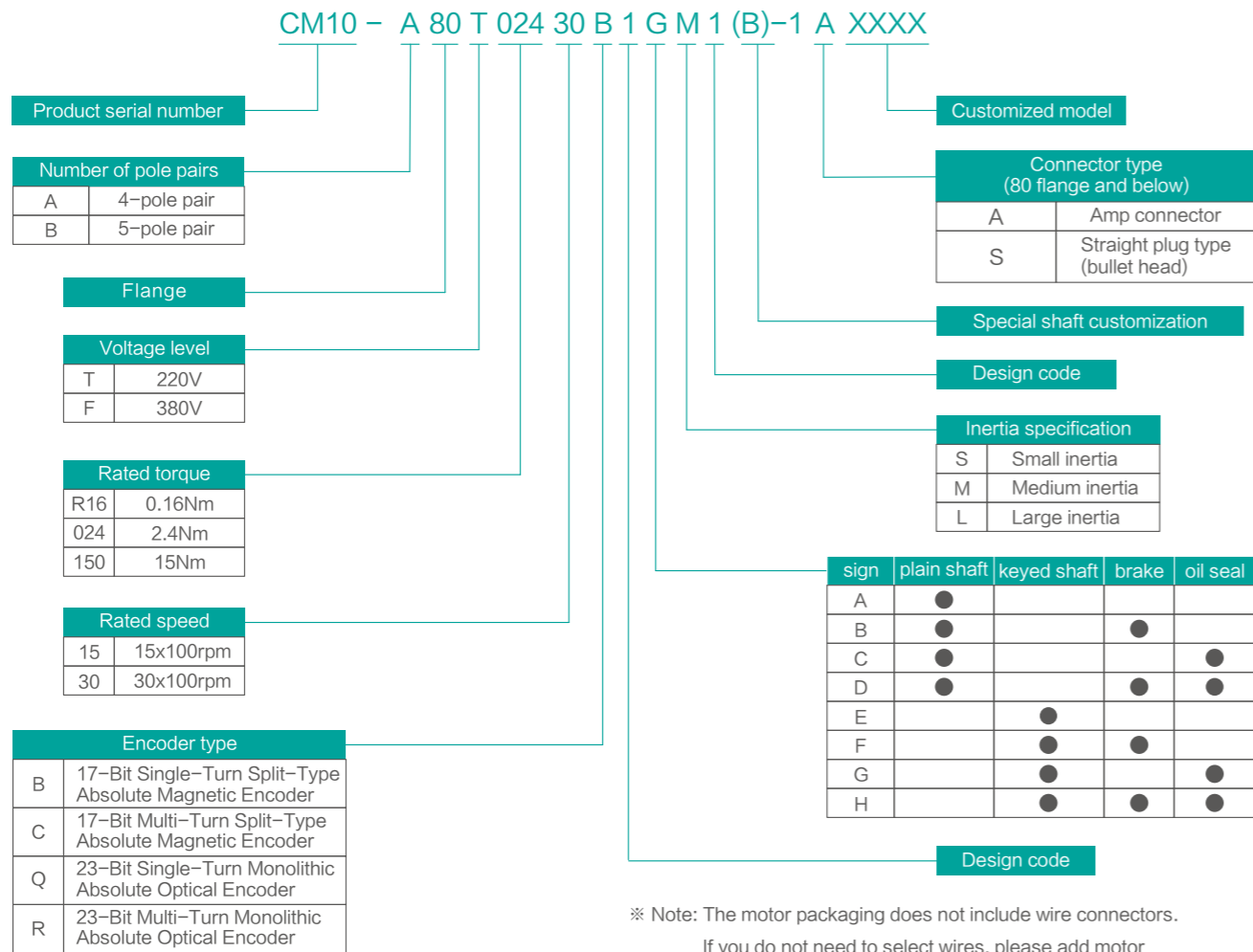

※ Note: The motor packaging does not include wire connectors. If you do not need to select wires, please add motor connector accessories.

Naming Rules for Cable

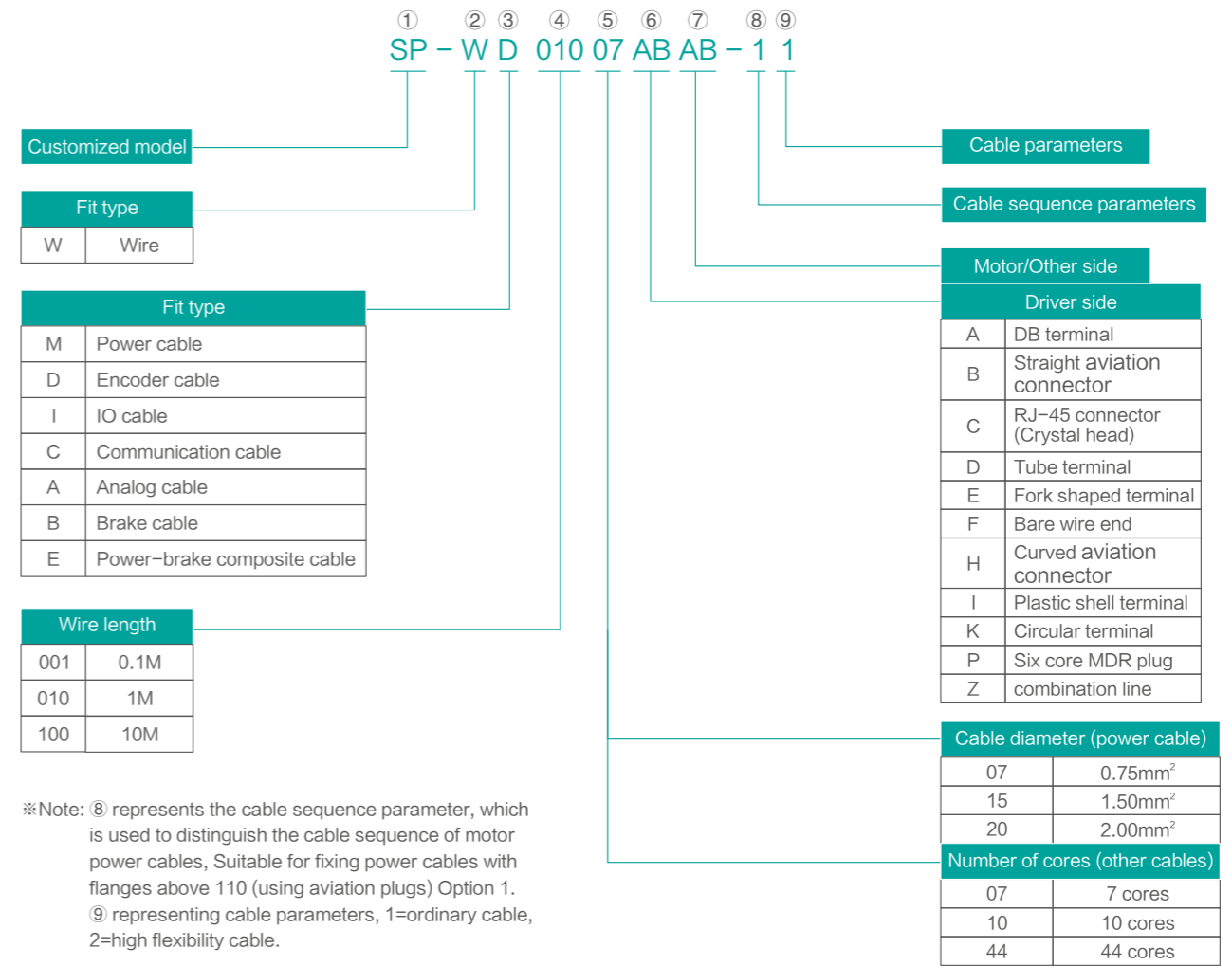

Motor Technical Parameters

Motor Specifications	Power (kW)	Rated Current (A)	Rated Torque (Nm)	Rated Speed (rpm)	Flange	Maximum Torque (Nm)	Maximum Speed (rpm)	Inertia (Kg · m ² × 10 ⁻⁴)	Torque Constant (Nm/A)	Back Electromotive Force (V/1krpm)	Cable Resistance (Ω)	Cable Inductance (mH)	Number of Pole Pairs	Frame Length
CM10-B40TR3230B3□L3	0.1	1	0.32	3000	40	0.96	6500	0.05 (0.053)	0.32	19	14.5	13.7	5	79.5(112.5)
CM10-B60TR6430C3□L2-1S	0.2	1.6	0.64	3000	60	1.92	6000	0.28(0.28)	0.40	25	5.8	10	5	79.5(112.5)
CM10-B60TR6430C3□L2	0.2	1.6	0.64	3000	60	1.92	6000	0.28(0.28)	0.40	25	5.8	10	5	76(105)
CM10-B60T01330C3□L2-2S	0.4	2.6	1.27	3000	60	3.81	6000	0.52(0.52)	0.49	31	4.3	7	5	94.5(123.5)
CM10-B60T01330C3□L2	0.4	2.6	1.27	3000	60	3.81	6000	0.52(0.52)	0.49	31	4.3	7	5	94.5(123.5)
CM10-B80T02430C3□L2-3S	0.75	3	2.40	3000	80	7.2	3500	1.48(1.48)	0.80	53	3.4	11	5	102(140)
CM10-B80T02430C3□L2-3A	0.75	3	2.40	3000	80	7.2	3500	1.48(1.48)	0.80	53	3.4	11	5	102(140)
CM10-B80T03230C3□L2-4S	1	4.5	3.20	3000	80	9.6	3500	1.93(1.93)	0.71	50	1.85	20	5	114(152)
CM10-B80T03230C3□L2-4A	1	4.5	3.20	3000	80	9.6	3500	1.93(1.93)	0.71	50	1.85	20	5	114(152)
CM10-B130T05430C3□M2	1.7	5.5	5.40	3000	130	16.2	3300	7.3(8.4)	0.98	60	1.1	11	5	149(207)
CM10-A130T07725C3□M3	2	7.5	7.70	2500	130	19.2	3000	14.1 (14.45)	1.03	68	1.2	6	4	192(229)
CM10-A130T10015C3□M3	1.5	6	10.00	1500	130	25	2000	18.8 (22.08)	1.67	108	1.85	10	4	209(265)
CM10-B130T08415C3□M2	1.3	9	8.40	1500	130	25.2	3000	10.4(11.1)	0.93	59.8	0.65	7	5	165(224)
CM10-B130T11515C3□M2	1.8	12	11.50	1500	130	34.5	3000	12.8(13.5)	0.96	60.8	0.44	6	5	180(239)
CM10-B130F05415C3□M2	0.85	3.5	5.40	1500	130	16.2	3000	7.3(8.4)	1.54	101	3.3	37	5	149(207)
CM10-A130F10015C3□M3	1.5	4	10.00	1500	130	25	2000	18.8 (22.08)	2.50	178	4.2	25	4	209(265)
CM10-B130F08415C3□M2	1.3	5.1	8.40	1500	130	25.2	3000	10.4(11.5)	1.65	105	1.9	22	5	165(224)
CM10-A130F15015C3□M3	2.3	5	15.00	1500	130	30	2000	25.5 (26.98)	3.00	180	3.2	19	4	231(282)
CM10-B130F09630C3□M2	3	8.4	9.60	3000	130	28.8	5000	12.8(13.9)	1.14	69	0.6	8	5	180(239)
CM10-B130F11515C3□M2	1.8	7	11.50	1500	130	34.5	3000	12.8(13.9)	1.64	106	1.3	17	5	180(239)
CM10-A180F19015R3□L3	3	7.5	19.00	1500	180	57	1800	63.5 (69.5)	2.53	166	1.33	14	4	205(252)
CM10-A180F27010R3□L3	2.9	7.5	27.00	1000	180	81	1250	88.5 (94.5)	3.60	241	1.67	18	4	232(279)
CM10-B180F18615R3□L2	2.9	11	18.60	1500	180	55.8	3000	47.9(49)	1.69	114	0.87	4	5	196.5(234)
CM10-A180F21520R3□L3	4.5	9.5	21.50	2000	180	64.5	2150	72.7 (78.7)	2.26	140	0.84	8	4	215(262)
CM10-A180F27015R3□L3	4.3	10	27.00	1500	180	81	1750	88.5 (94.5)	2.70	172	1	10	4	232(279)
CM10-B180F28415R3□L2	4.5	17	28.40	1500	180	85.2	3000	71.5(72.6)	1.67	112	0.38	4	5	221.5(259)
CM10-B180F35015R3□L2	5.5	21	35.00	1500	180	87.5	3000	118.1(124.1)	1.67	113	0.2	3	5	257.5(295)
CM10-B180F48015R2□L2	7.5	26	48.00	1500	180	120	3000	149.6(150.7)	1.85	115	0.14	2	5	303.5(341)
CM10-A200F70015R2□L2B	11	21	70.00	1500	200	175	1800	97.7	3.33	220	0.95	10.3	4	438(538)

The □ suffix of the motor: G=No holding brake;
H=With brake

Encoder type(5th to last specification):
C=17 bit multi turn magnetic encoder,
R=23 bit multi turn optical encoder
Voltage level: T=220V, F=380V

The inertia with brake in parentheses

Excluding shaft length and end cover thickness, the bracket indicate the length of the frame with a brake

Size Diagram of Servo Motor (unit: mm)

60 flange

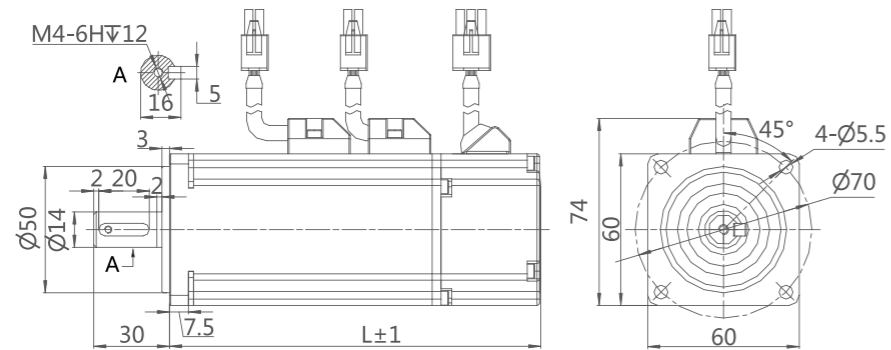

80 flange

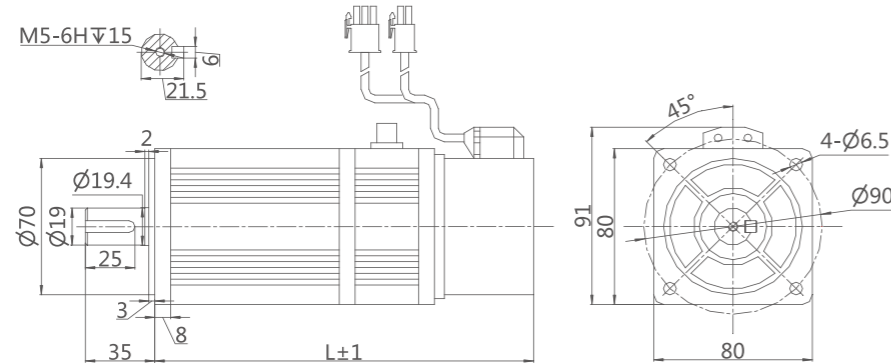

130 flange

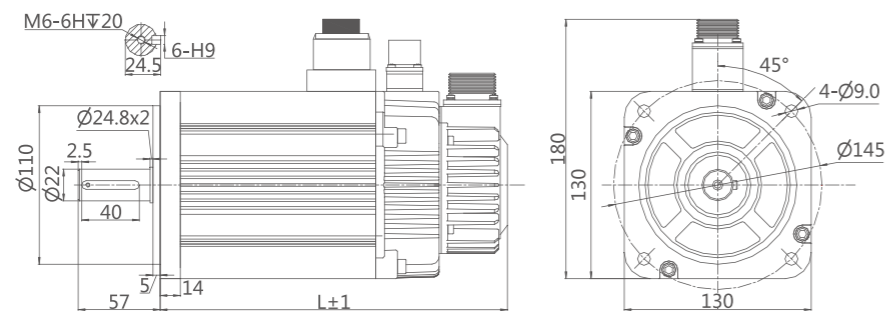

180 flange

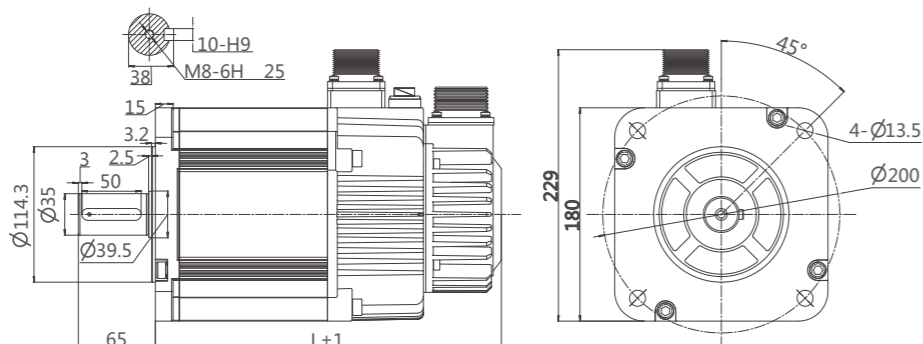

Cable Harness Specification and Model Diagram

Power Cable

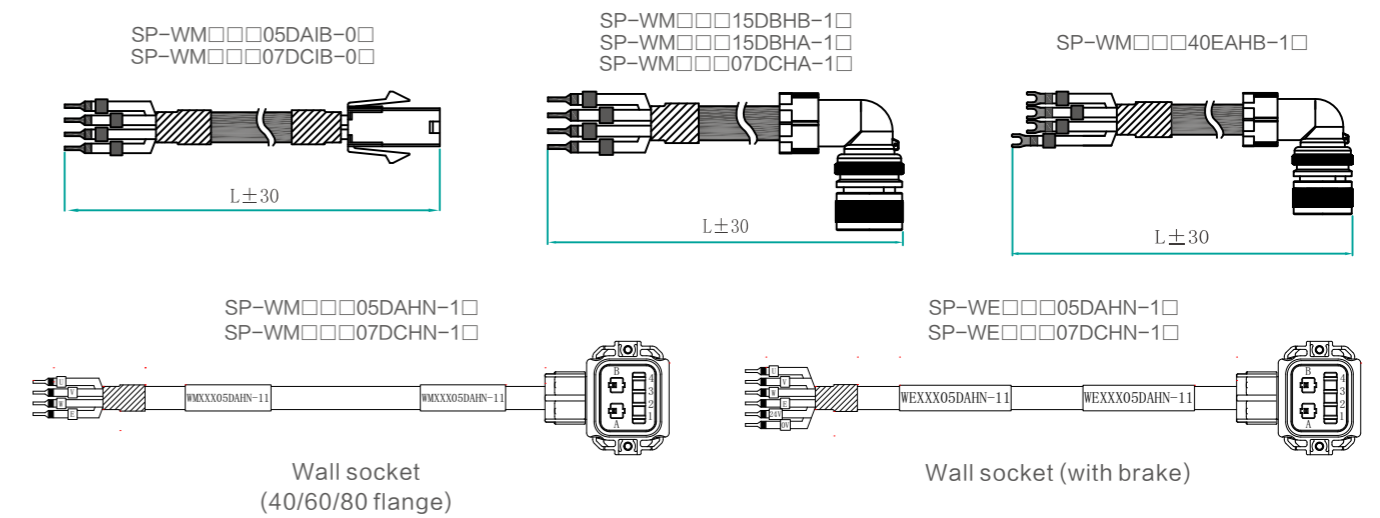

Figure 1: Motor Power Cable Terminal

Motor terminal wire sequence					Driver side
Motor flange type	Terminal view	Terminal number	Pin	Definition	Motor flange type
40/60/80 Using AMP connector			1	PE	
			2	U	
			3	V	
			4	W	
40/60/80 flange push-in terminal plugs for motor applications under reciprocating motion, high temperature, high humidity and harsh environments.					
40/60/80 · Push-in plug (with brake)			1	U	
			2	V	
			3	W	
			4	PE	
			A	24V	
			B	0V	
80 flange: small aviation connector replaces Amp plug For motors in harsh environments: reciprocating motion, high temperature & high humidity					
80(Using small-sized aviation connector) 130/180 Using aviation connector			1	PE	
			2	U	
			3	V	
			4	W	

Encoder Cable

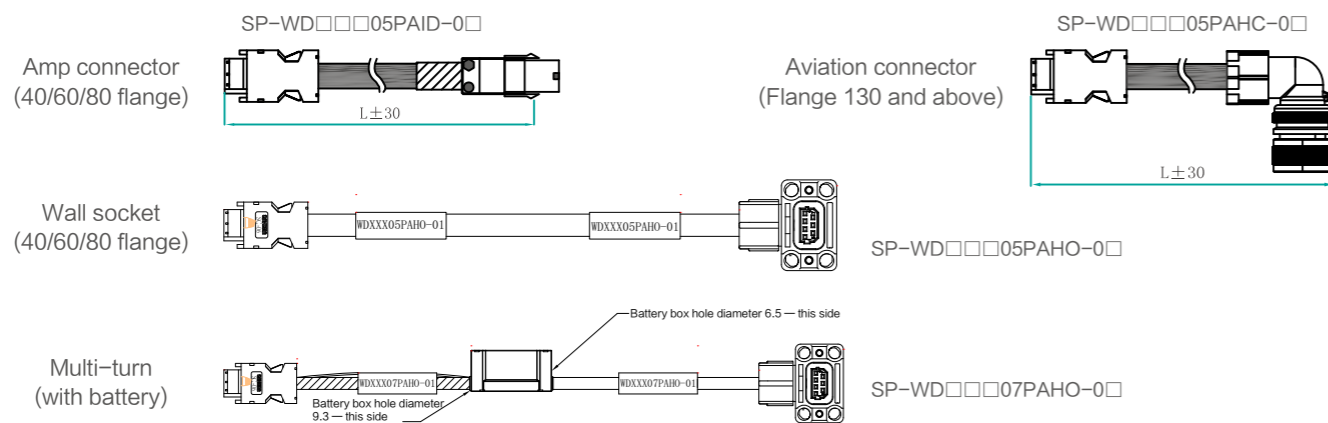

Figure 2: Definition of Encoder Cable Terminal

Motor terminal cable sequence				Driver side	
Motor flange type	Terminal view	Terminal number	Pin	Definition	Pin
40/60/80 Using AMP connector			1	PE	PE
			2	5V	4
			3	0V	3
			4	SD+	1
			5	SD-	2
			6	E+	NC
			7	E-	NC
			8	NC	NC
			9	NC	NC
40/60/80 flange push-in terminal plugs for motor applications under reciprocating motion, high temperature, high humidity and harsh environments.					
40/60/80 · Push-in plug			1	PE	PE
			2	E-	NC
			3	E+	NC
			4	SD-	2
			5	0V	3
			6	SD+	1
			7	5V	4
			8	NC	NC
			9	NC	NC
80 flange: small aviation connector replaces Amp plug For motors in harsh environments: reciprocating motion, high temperature & high humidity					
80 (Using small-sized aviation connector)			1	PE	NC
			2	E-	NC
			3	E+	NC
			4	SD-	2
			5	0V	3
			6	SD+	1
			7	5V	4
130/180 Using aviation connector			1	PE	NC
			2	E-	NC
			3	E+	NC
			4	SD-	2
			5	0V	3
			6	SD+	1
			7	5V	4

Encoder Wiring Precautions: Reliably ground the encoder shielding braid on the drive and motor sides to avoid false drive alarms.

Brake Cable

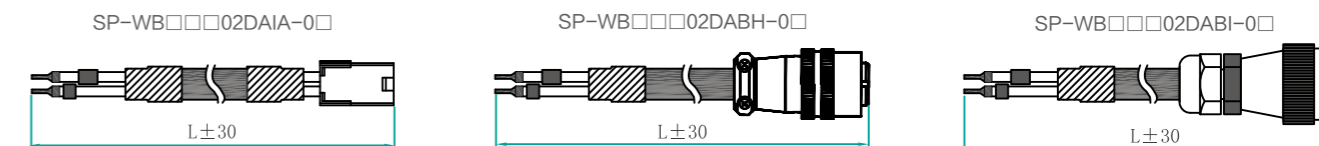

Figure 3: Holding brake terminal

Motor flange type	Brake terminal model	Motor side terminal	Pin	Definition
40/60	172233-1		1	24V
			2	0V
80/130	XS12K3P		1	24V
			2	0V
			3	NC
180	XS16K4TM		1	24V
			2	0V
			3	NC
			4	NC

Selection of Regenerative Braking Resistor

When the motor's output torque opposes its operating speed direction, the motor enters a regenerative state. This feedback energy elevates the bus voltage, with the energy magnitude determined by the combined inertia of the motor rotor and load. For systems with low inertia, the driver's internal bus capacitors can sufficiently absorb the regenerative energy. However, in high-inertia systems, the braking resistor must dissipate the excess energy as the bus capacitors reach capacity. Uncontrolled bus voltage rise may trigger overvoltage protection (causing emergency stops) or potentially damage the drive system.

Selection Table for Regenerative Braking Resistor

Drive model	Specification of built-in regenerative braking resistor		Allow minimum external resistance value (Ω)	Capacitor can absorb maximum braking energy EC (J)	
	Resistance value (Ω)	Capacity (W)			
Single-phase AC220V	CD200-T1R8	null	50	11	
	CD200-T3R0	null	50	16	
	CD200-T4R0	null	50	16	
Single-phase/ three-phase AC220V	CD200-T4R5	50 (optional)	40	19	
	CD200-T5R5	50 (optional)	40	29	
	CD200-T7R5	25 (optional)	100	34	
	CD200-T10R	25 (optional)	100	48	
	CD200-T13R	25 (optional)	100	60	
	CD200-T16R	25 (optional)	100	60	
Three-phase AC380V	CD200-F4R0	100 (optional)	80	33	
	CD200-F6R5	100 (optional)	60	33	
	CD200-F8R5	50 (optional)	100	33	
	CD200-F12R	50 (optional)	100	48	
	CD200-F17R	40 (optional)	150	60	
	CD200-F22R	30 (optional)	150	80	
	CD200-F27R	30 (optional)	150	96	
	CD200-F38R	null	null	10	144
	CD200-F52R	null	null	10	192
CD200-F62R	null	null	10	240	

- When utilizing an external braking resistor:
Connection Requirements: Must be wired between P+ and C terminals, P+ to D circuit must remain open (no connection);
- Resistor Specifications: Minimum resistance must exceed values in Table, Non-compliance risks drive unit damage.

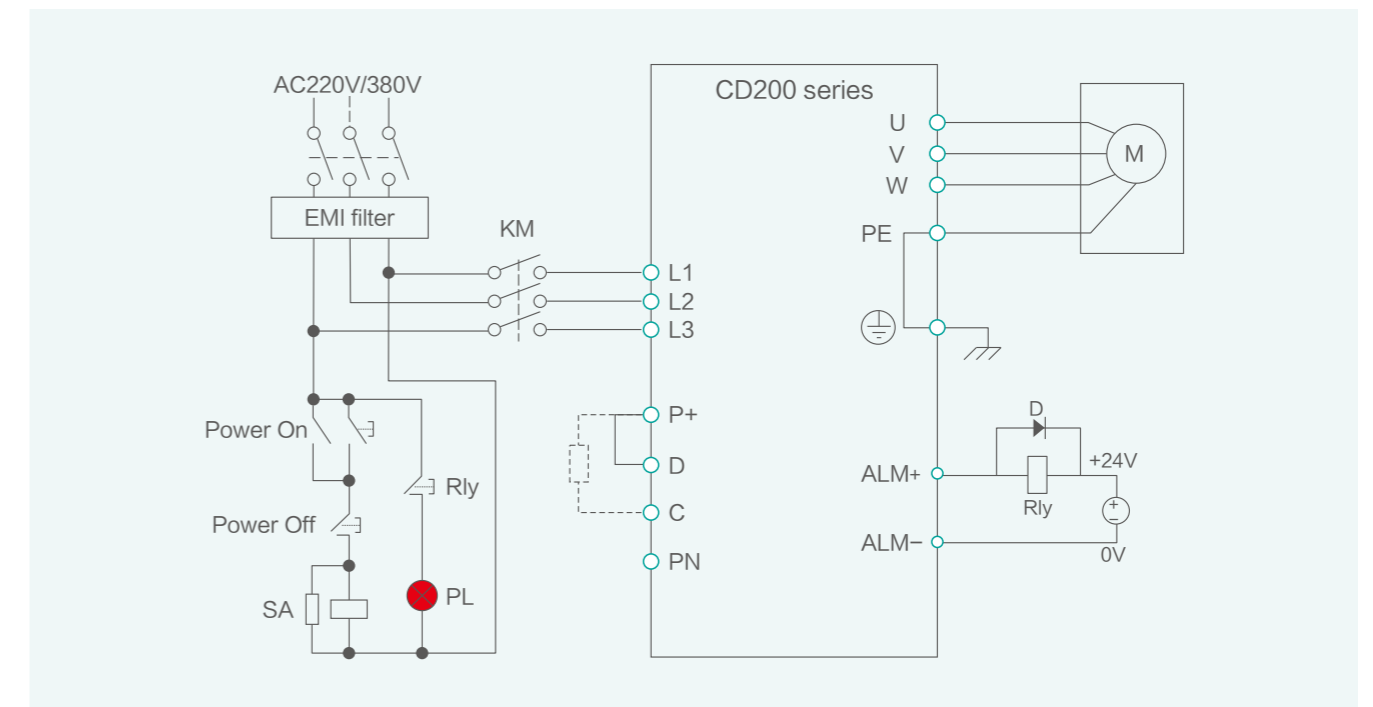
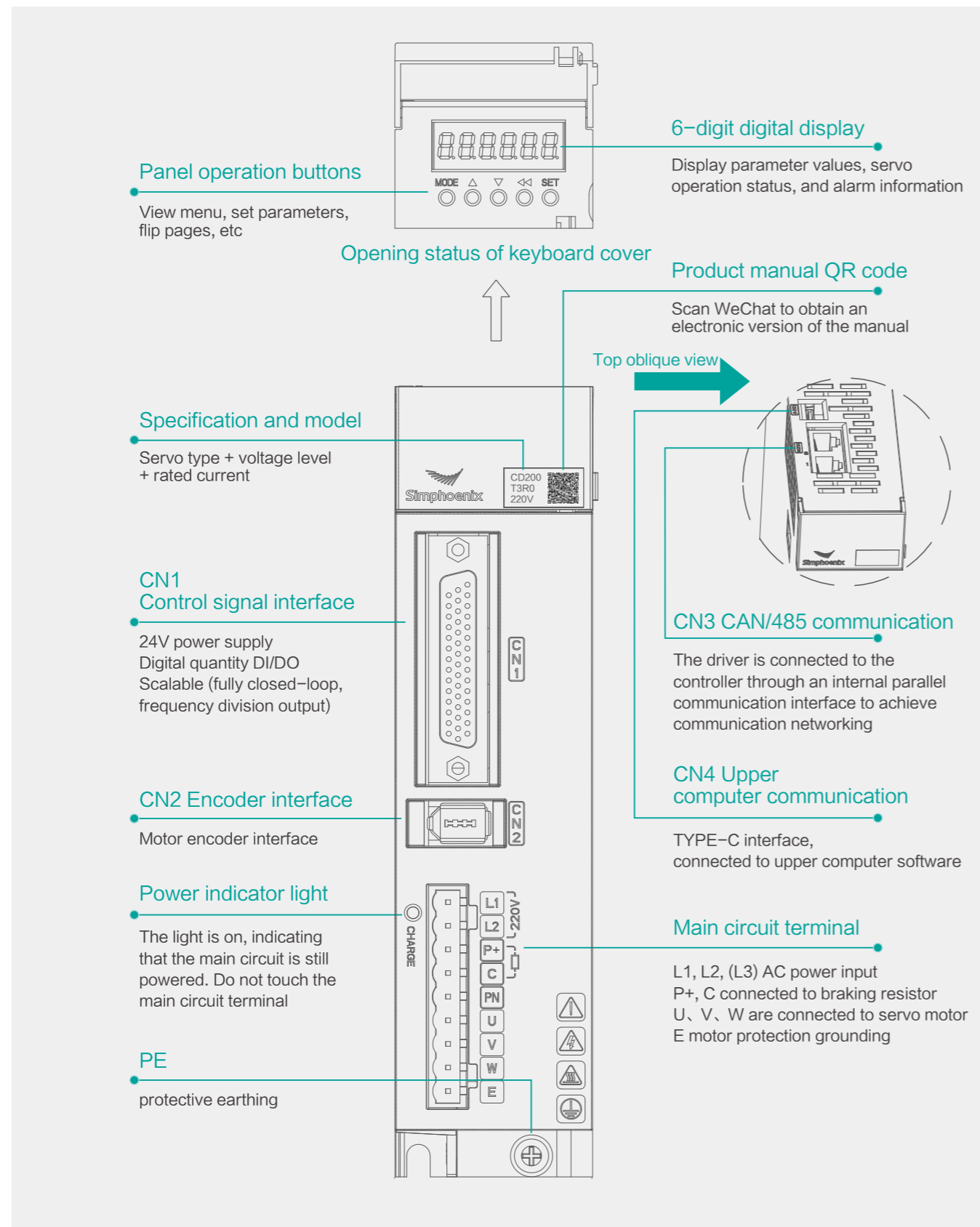

Name and Function of Main Circuit Terminal

Terminal Number	Terminal Name	Drive Model (CD200-)	Terminal Function
L1, L2, L3	power input	T1R8/T3R0/T4R0	Single-phase AC220V power input (without L3 terminal)
		T4R5-T7R5	Single-phase/three-phase AC220V power input
		F4R0-F62R	Three-phase 380V power input
P+, D, C	braking resistor	T1R8/T3R0	Internal brake: not equipped External brake: connect between P+ and C terminals
		T4R5-T13R F4R0-F27R	Internal Braking (Optional) Resistor connection: Short-circuit between P+ and D; External Braking Resistor connection: Between P+ and C terminals and maintain open circuit between P+ and D.
		F38R-F62R	Internal brake: not equipped; External Braking Resistor connection: Between P+ and C terminals and maintain open circuit between P+ and D.
U, V, W	motor		The power line connection terminals of the servo motor are respectively connected to the U/V/W of the motor.
P+, PN	common DC bus terminal		The common DC bus terminal of the servo drive can share the same bus when multiple machines are connected in parallel.
N1, N2	external reactor terminal		By default, a short-circuit terminal is connected between PN1 and PN2. When it is necessary to suppress high-order harmonics of the power supply, the short-circuit terminal is removed between N1 and N2, and an external DC reactor is connected.
PE	ground terminal		Connect to the grounding terminal of the power supply and the grounding terminal of the motor.

Servo Peripheral Devices and Wiring (1)

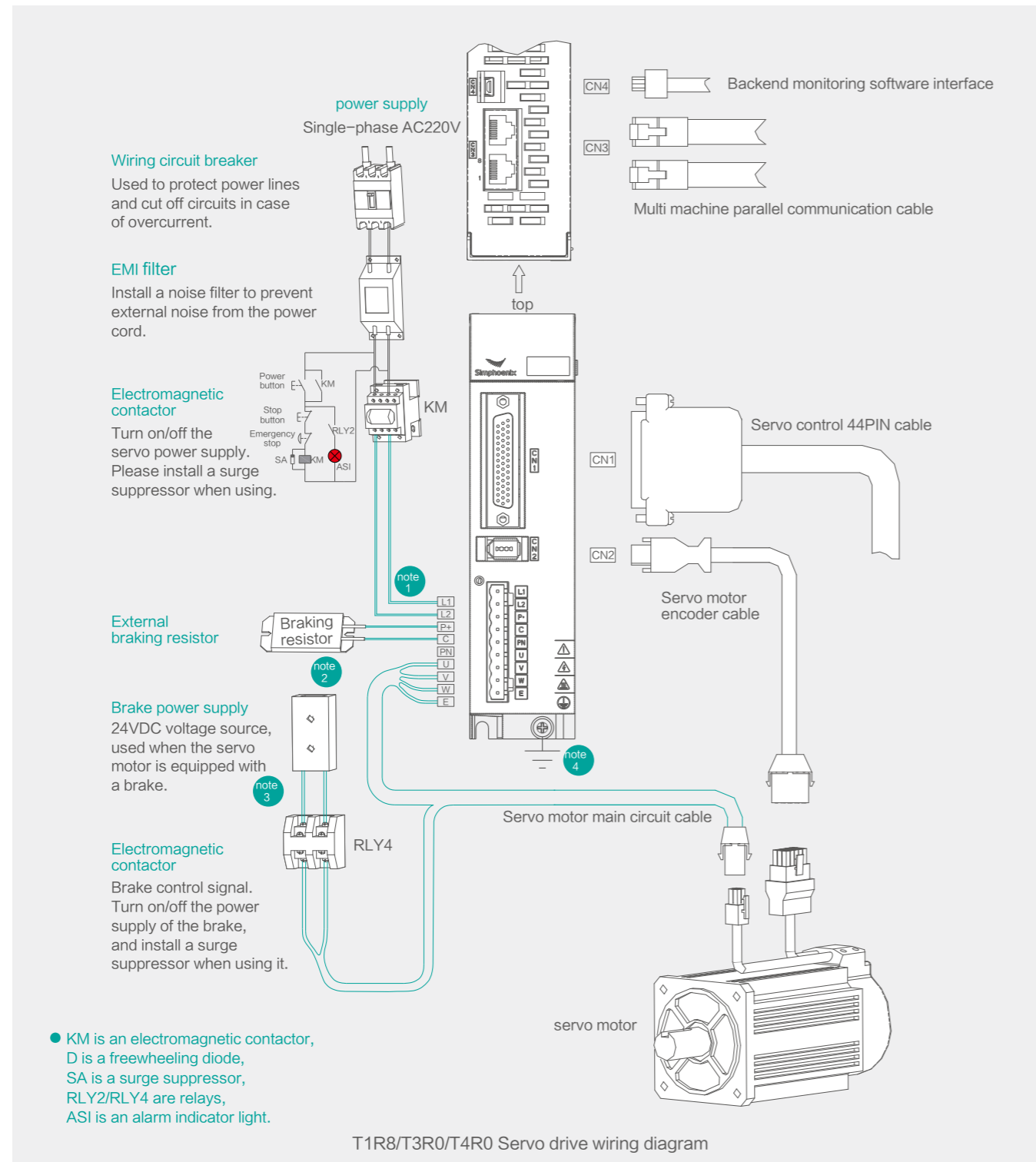

Servo Peripheral Devices and Wiring (2)

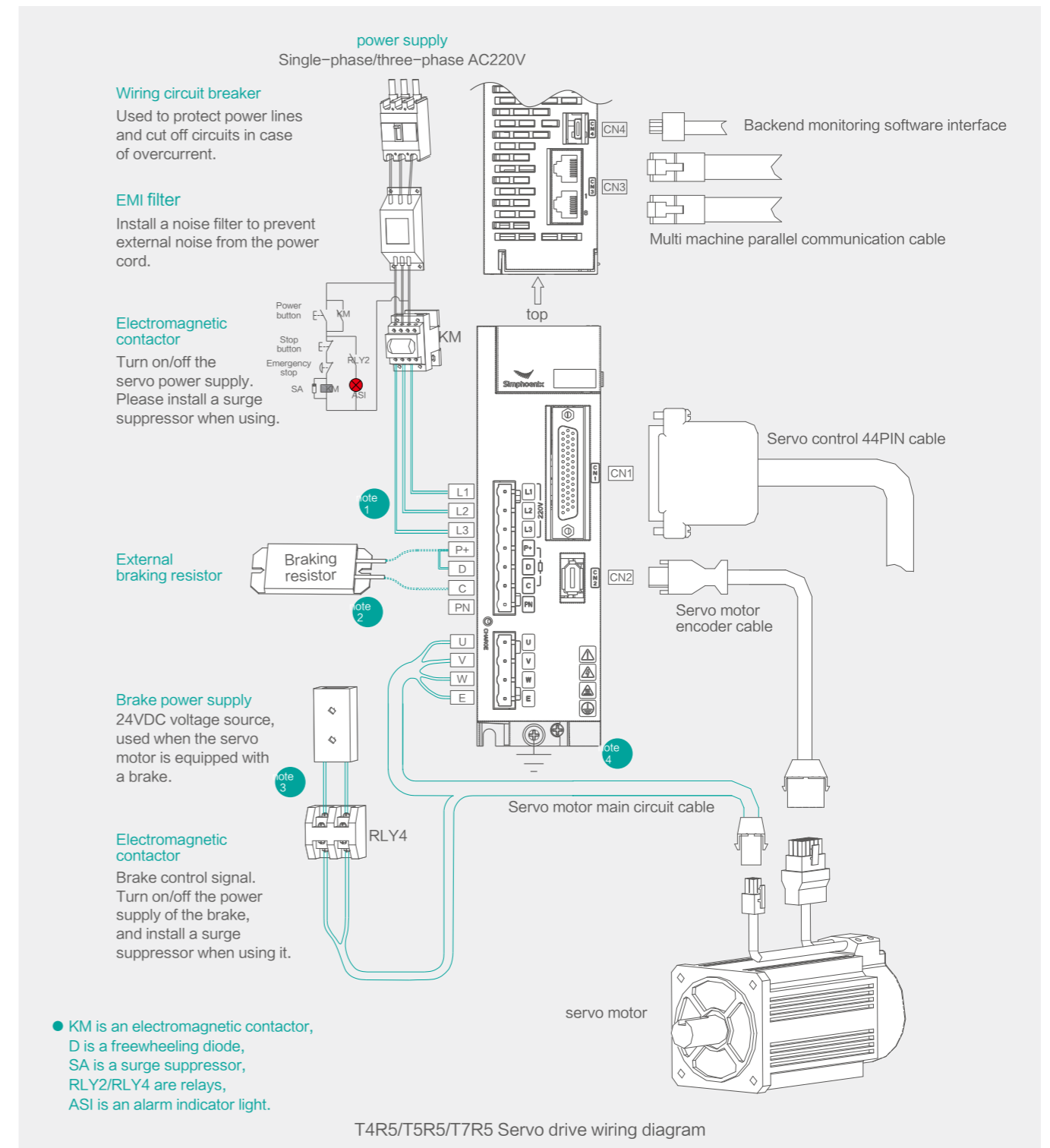

- Note 1: T1R8/T3R0 are single-phase AC220V power input
 Note 2: T1R8/T3R0 do not have built-in braking resistors, external braking resistors are connected between P+ and C
 Note 3: The 24V power supply for electromagnetic braking needs to be provided by the user and must be isolated from the 12-24V power supply for control signals
 Note 4: The shielding layer of the motor output cable is connected to the product output PE terminal, and the main circuit input PE terminal is connected to the control cabinet grounding copper bar through a protective grounding conductor

- Note 1: T4R5/T5R5/T7R5 can be connected to single-phase AC 220V or three-phase AC 220V
 Note 2: T4R5/T5R5/T7R5 external braking resistor is connected between P+ and C, and there is an open circuit between P+ and D; T4R5/T5R5/T7R5 external braking resistor needs to be short circuited with P+ and D, and a built-in braking resistor can be optionally installed at the factory
 Note 3: The 24V power supply for electromagnetic braking needs to be provided by the user and must be isolated from the 12-24V power supply for control signals
 Note 4: The shielding layer of the motor output cable is connected to the product output PE terminal, and the main circuit input PE terminal is connected to the control cabinet grounding copper bar through a protective grounding conductor

Servo Peripheral Devices and Wiring (3)

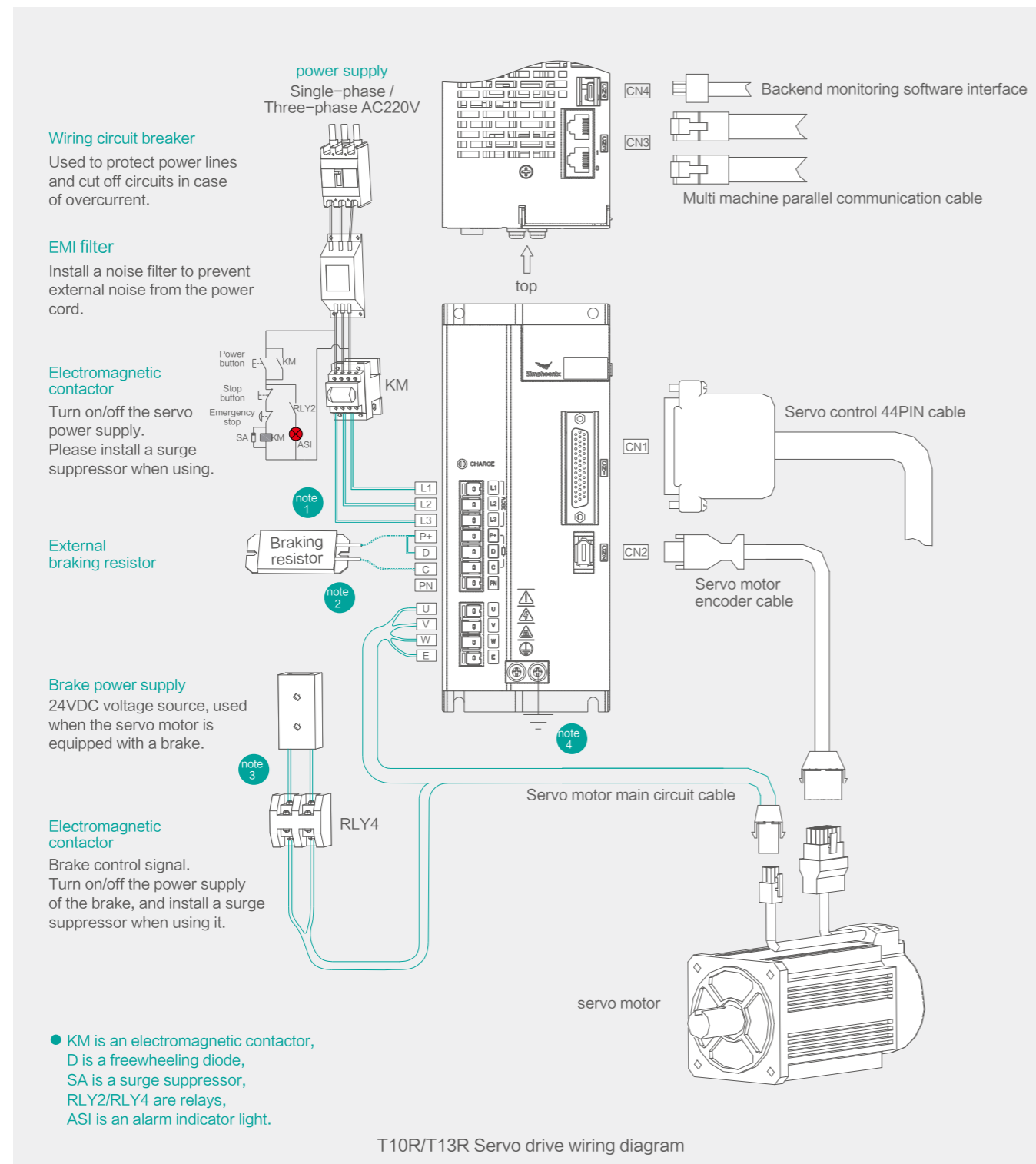

Servo Peripheral Devices and Wiring (4)

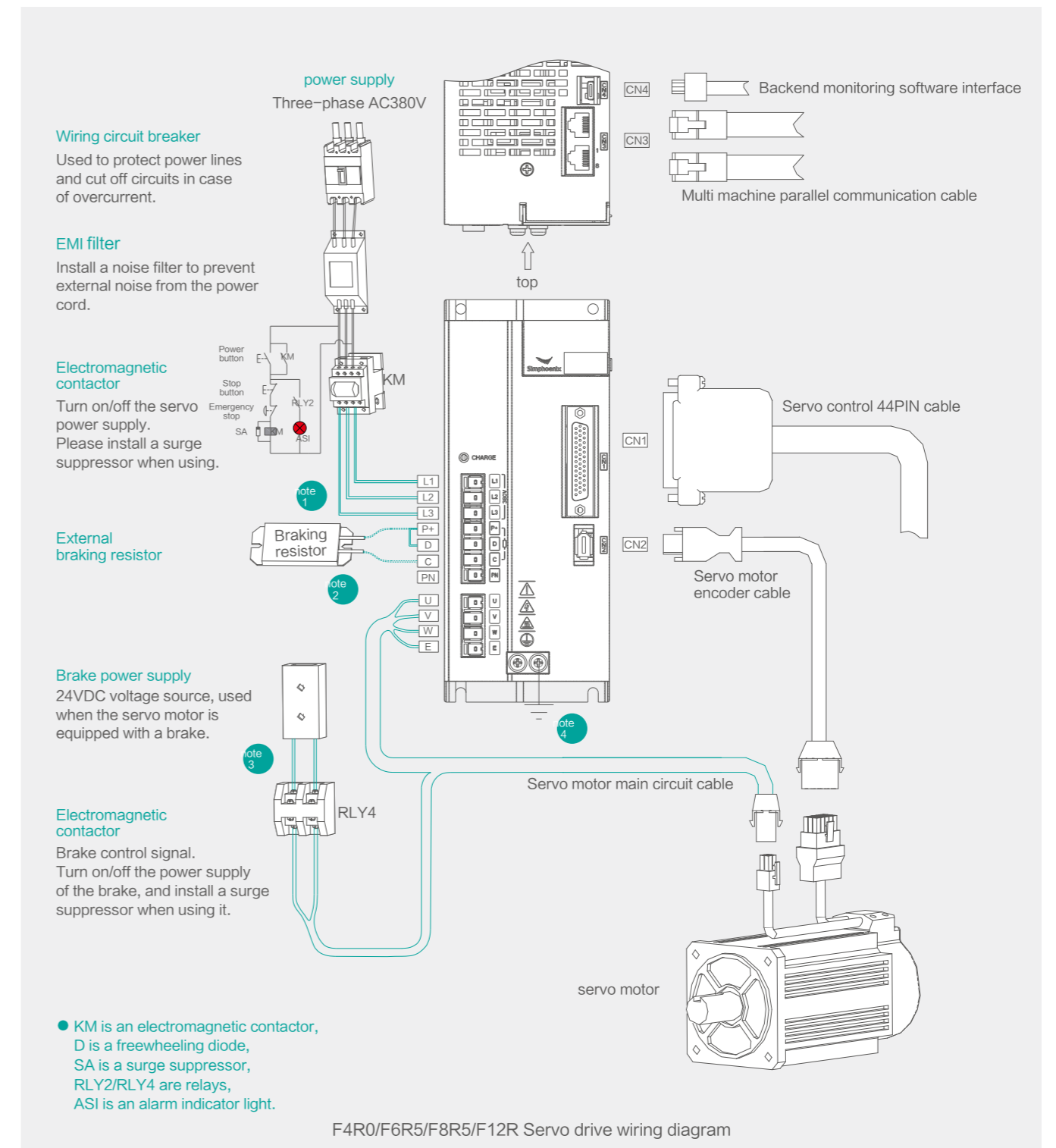

- Note 1: T10R / T13R can be connected to three-phase AC 220V or single-phase AC 220V.
- Note 2: T10R / T13R external braking resistor is connected between P+and C, and there is an open circuit between P+and D;
T10R / T13R external braking resistor needs to be short circuited with P+and D, and a built-in braking resistor can be optionally installed at the factory
- Note 3: The 24V power supply for electromagnetic braking needs to be provided by the user and must be isolated from the 12-24V power supply for control signals
- Note 4: The shielding layer of the motor output cable is connected to the product output PE terminal, and the main circuit input PE terminal is connected to the control cabinet grounding copper bar through a protective grounding conductor

- Note 1: F4R0-F12R are three-phase AC380V power input
- Note 2: F4R0-F12R external braking resistor is connected between P+and C, and there is an open circuit between P+and D;
F4R0-F12R external braking resistor needs to be short circuited with P+and D, and a built-in braking resistor can be optionally installed at the factory
- Note 3: The 24V power supply for electromagnetic braking needs to be provided by the user and must be isolated from the 12-24V power supply for control signals
- Note 4: The shielding layer of the motor output cable is connected to the product output PE terminal, and the main circuit input PE terminal is connected to the control cabinet grounding copper bar through a protective grounding conductor

Servo Peripheral Devices and Wiring (5)

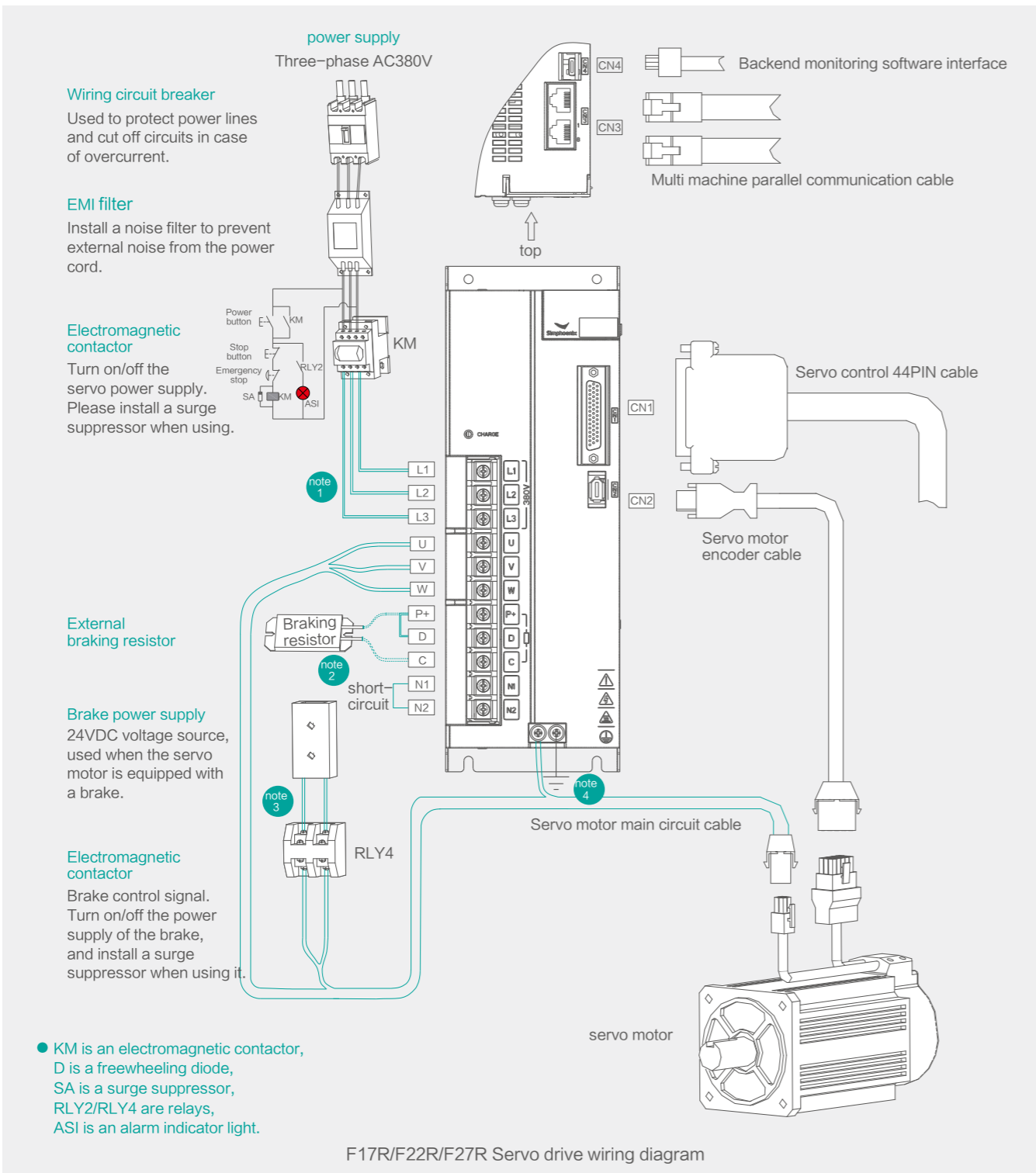

- Note 1: F17R~F27R are three-phase AC380V power input
- Note 2: F17R~F27R external braking resistor is connected between P+and C, and there is an open circuit between P+and D;
F17R~F27R external braking resistor needs to be short circuited with P+and D, and a built-in braking resistor can be optionally installed at the factory
- Note 3: The 24V power supply for electromagnetic braking needs to be provided by the user and must be isolated from the 12~24V power supply for control signals
- Note 4: The shielding layer of the motor output cable is connected to the product output PE terminal, and the main circuit input PE terminal is connected to the control cabinet grounding copper bar through a protective grounding conductor

Control Circuit Wiring

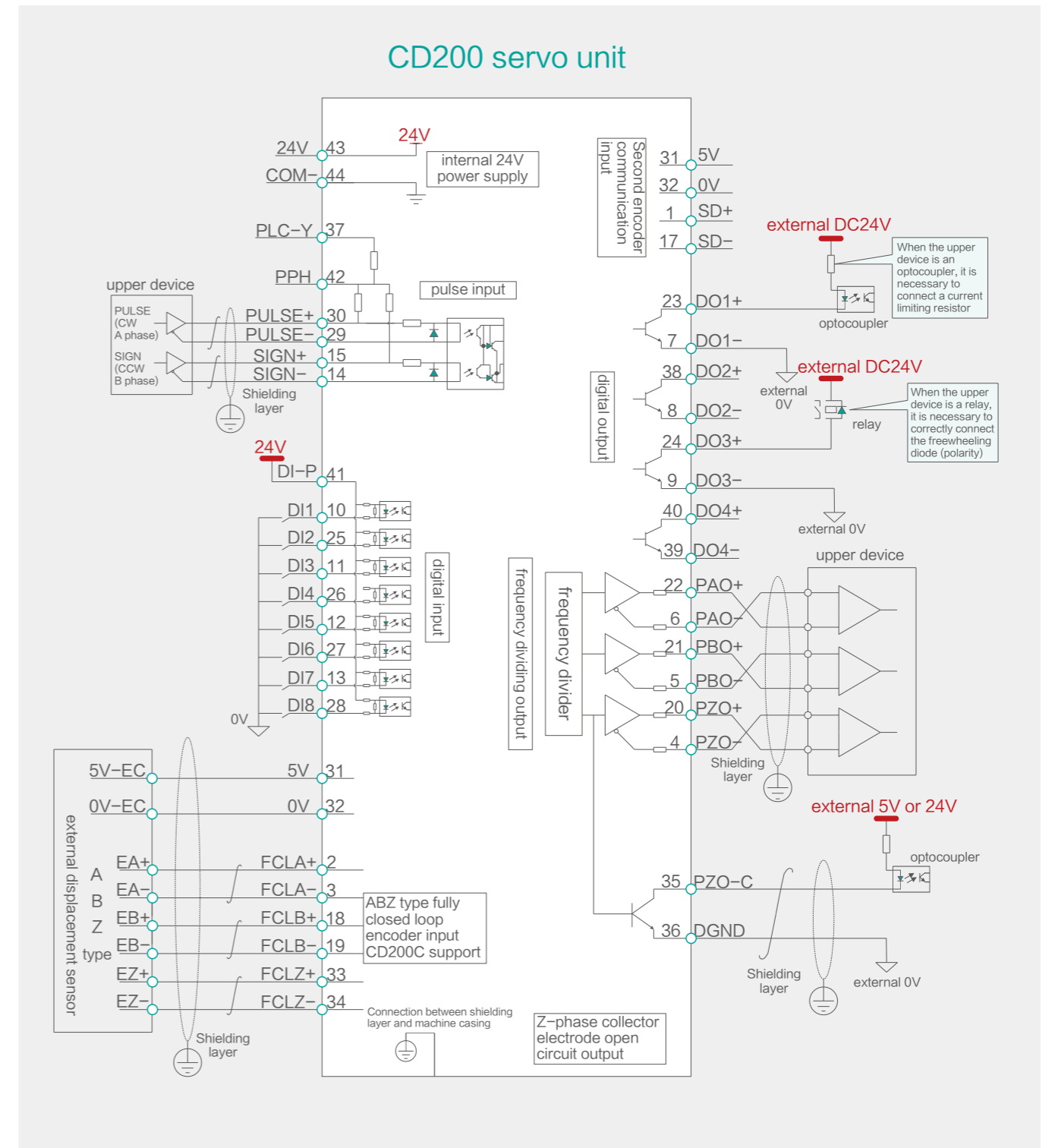

- ※explanation:
- [1] The internal 24V power supply has a voltage range of 20V~28V and a maximum operating current of 100mA.
- [2] Please use twisted pair shielded wire for pulse port wiring. The shielding layer must be connected to PE at both ends, and DGND must be reliably connected to the signal ground of the upper computer.
- [3] The DO output power supply should be provided by the user, with a power range of 5V~24V. The maximum allowable voltage for the DO port is 30VDC, and the maximum allowable current is 50mA.
- [4] Please use twisted pair shielded cables for frequency division output. The shielding layer must be connected to PE at both ends, and DGND must be reliably connected to the signal ground of the upper computer.